



# TAI-SAW TECHNOLOGY CO., LTD.

No. 3, Industrial 2nd Rd., Ping-Chen Industrial District,  
Taoyuan, 324, Taiwan, R.O.C.

TEL: 886-3-4690038 FAX: 886-3-4697532

E-mail: [tstsales@mail.taisaw.com](mailto:tstsales@mail.taisaw.com) Web: [www.taisaw.com](http://www.taisaw.com)

## Product Specifications Approval Sheet

Product Description: 69.5MHz 6MHz BW SMD 7.0 x 5.0 mm SAW IF Filter

TST Parts No.: TB1201A

Customer Parts No.: \_\_\_\_\_

Customer signature required
Company: _____
Division: _____
Approved by : _____
Date: _____

Checked by: \_\_\_\_\_ Kazuma Lee 

Approval by: \_\_\_\_\_ Bob Chau 

Date: \_\_\_\_\_ 10 / 06 / 2015

1. Customer signed back is required before TST can proceed with sample build and receive orders.
2. Orders received without customer signed back will be regarded as agreement on the specifications.
3. Any specifications changes must be approved upon by both parties and a new revision of specifications shall be released to reflect the changes.



# TAI-SAW TECHNOLOGY CO., LTD.

No.3, Industrial 2nd Rd., Ping-Chen Industrial District, Taoyuan, Taiwan, R.O.C.

TEL: 886-3-4690038 FAX: 886-3-4697532

E-mail: [tstsales3@mail.taisaw.com](mailto:tstsales3@mail.taisaw.com) Web: [www.taisaw.com](http://www.taisaw.com)

SAW Filter 69.5MHz 6MHz BW (SMD 7.0x5.0mm)

MODEL NO.: TB1201A

REV. NO.1

## A. MAXIMUM RATING:

1. Operating temperature range: -40°C to 85°C
2. Storage temperature range: -40°C to 85°C
3. Input Power Level : 10 dBm
4. Maximum DC Voltage : 10V

RoHS Compliant  
Lead free  
Lead-free soldering

Electrostatic Sensitive Device

## B. CHARACTERISTICS:

1. Ambient Temperature: 25 °

Item	Unit	Min.	Type.	Max.
Center frequency, <b>Fc</b>	MHz	-	69.5	-
Insertion Loss, <b>IL</b>	dB	-	10.8	12.0
1dB Band Width	MHz	5.0	6.3	-
3dB Band Width	MHz	-	7.3	-
35dB Band Width	MHz	-	11.4	12.3
Amplitude Ripple Fc+/-2.5MHz	dB	-	0.5	1.0
Group Delay Ripple Fc+/-2.5MHz	ns	-	50	-
Absolute Group Delay at Fc	us	-	0.73	-
Attenuation (Reference level from minimum Insertion loss )				
10MHz ~ 63MHz	dB	40	42	-
63MHz ~ 64MHz	dB	20	31	-
Temperature Coefficient	ppm/°C	-	-94	-
Source Impedance	Ohm	-	75	-
Load Impedance	Ohm	-	75	-

### C. FREQUENCY CHARACTERISTICS:

#### (1) Wide Band Response:(span 100MHz)

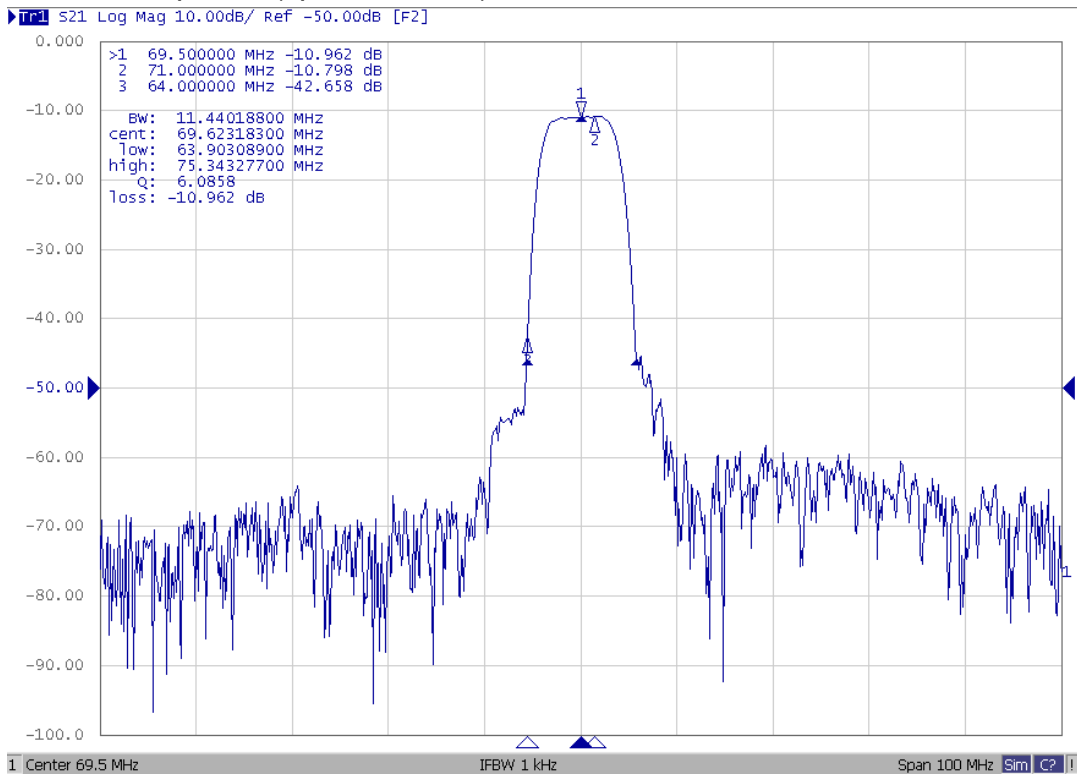

Fig1. Horizontal: 10MHz/Div Vertical: 10dB/Div

#### (2) Pass Band Response and Group Time Delay Response:

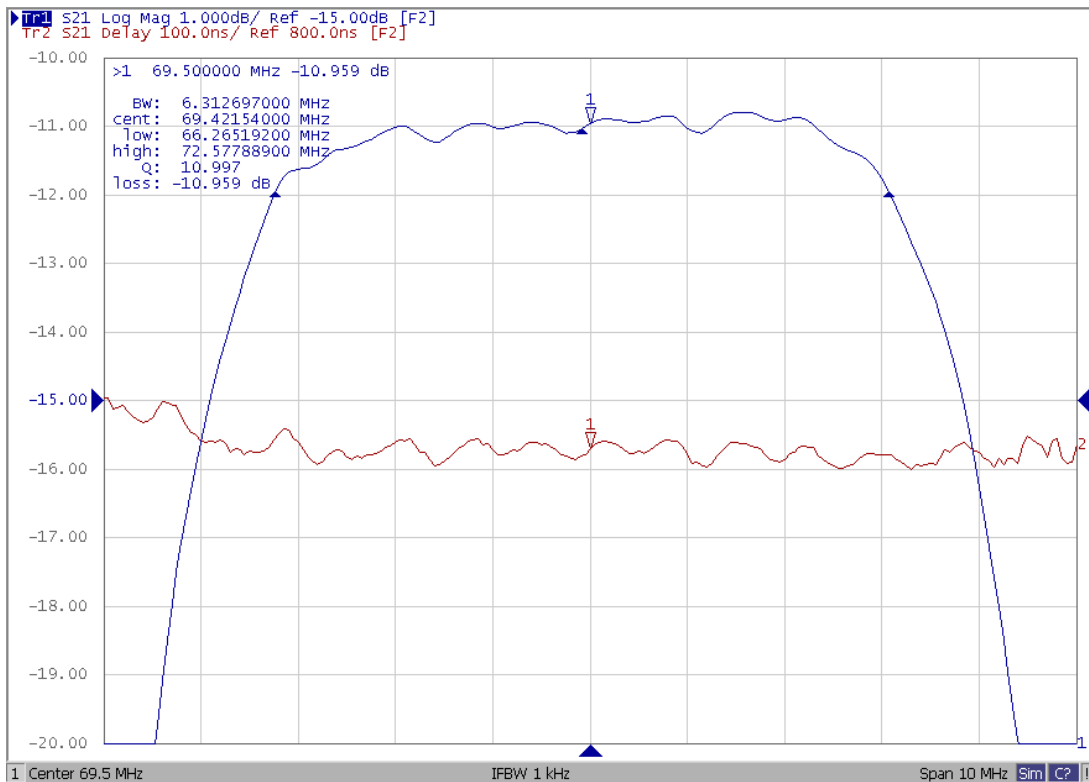
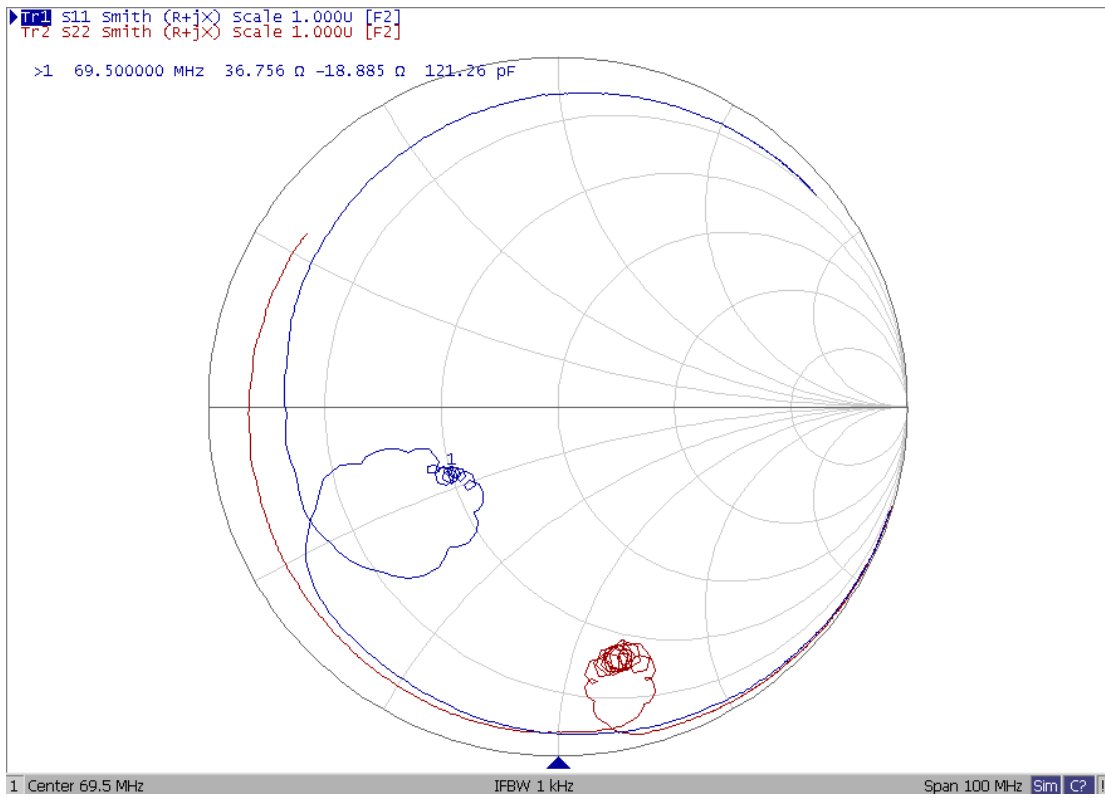
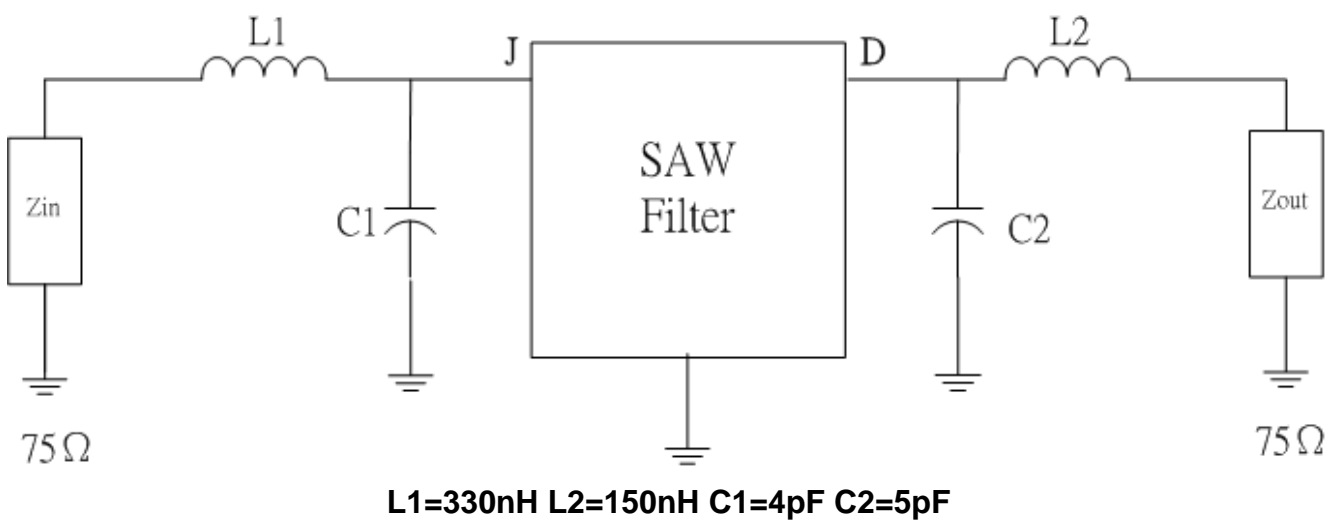

Fig2. Horizontal: 1MHz/Div Vertical: 1dB/Div  
Vertical: 100ns/Div

(3) Smith Chart:



D. MATCHING CIRCUIT:



## E. OUTLINE DRAWING:

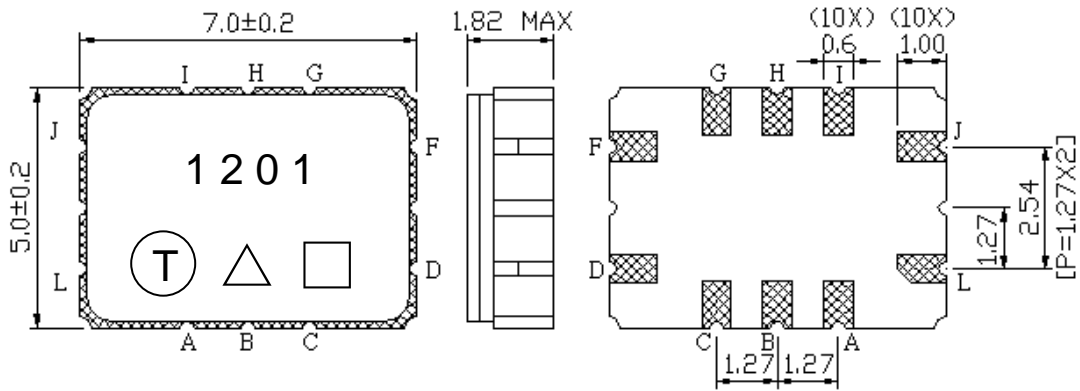

Pin J: RF Input

Pin D: RF Output

Pin A, B, C, E, F, G, H, I, L: To be ground

Unit : mm

□ : Week Code

△ : Product / Year Code

Year	2013 2017	2014 2018	2015 2019	2016 2020
Product Code	B	b	<u>B</u>	<u>b</u>

### Week Code Table

WK01	WK02	WK03	WK04	WK05	WK06	WK07	WK08	WK09	WK10	WK11	WK12	WK13
A	B	C	D	E	F	G	H	I	J	K	L	M
WK14	WK15	WK16	WK17	WK18	WK19	WK20	WK21	WK22	WK23	WK24	WK25	WK26
N	O	P	Q	R	S	T	U	V	W	X	Y	Z
WK27	WK28	WK29	WK30	WK31	WK32	WK33	WK34	WK35	WK36	WK37	WK38	WK39
a	b	c	d	e	f	g	h	i	j	k	l	m
WK40	WK41	WK42	WK43	WK44	WK45	WK46	WK47	WK48	WK49	WK50	WK51	WK52
n	o	p	q	r	s	t	u	v	w	x	y	z

**F. PCB FOOTPRINT:**

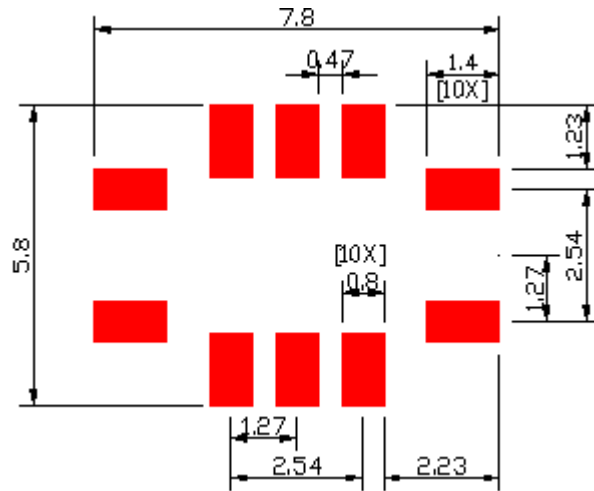

**G. PACKING:**

1. REEL DIMENSION (Please refer to FR-75D10 for packing quantity)

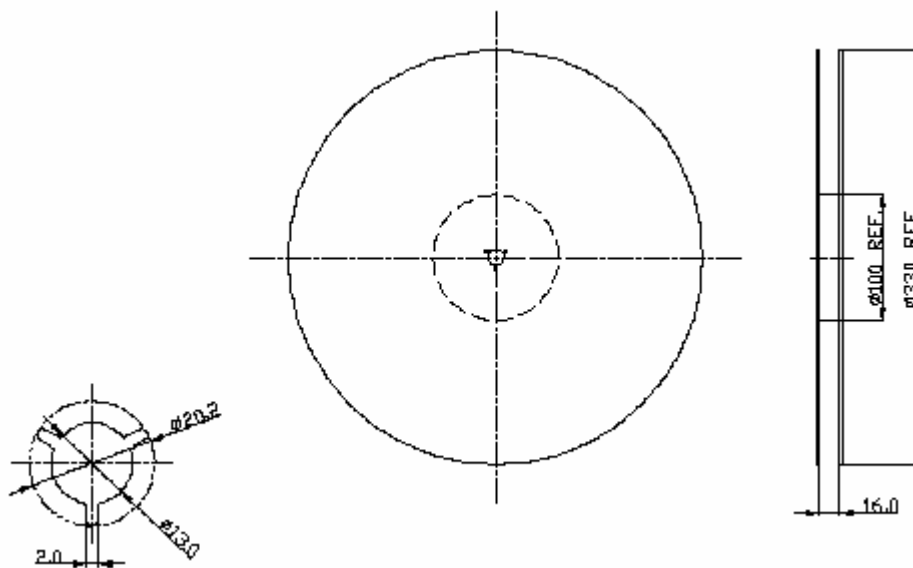

## 2. TAPE DIMENSION

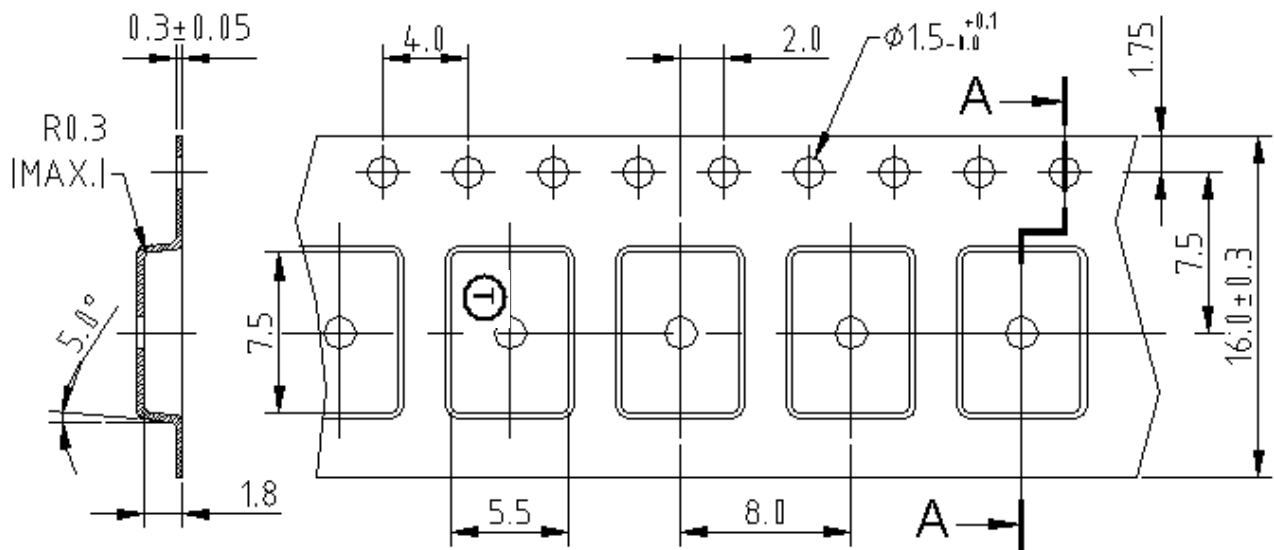

### H. RECOMMENDED REFLOW PROFILE:

1. Preheating shall be fixed at  $150\sim 180^\circ\text{C}$  for 60~90 seconds.
2. Ascending time to preheating temperature  $150^\circ\text{C}$  shall be 30 seconds min.
3. Heating shall be fixed at  $220^\circ\text{C}$  for 50~80 seconds and at  $260^\circ\text{C} +0/-5^\circ\text{C}$  peak (20~40sec).
4. Time: 2 times.

