



# TAI-SAW TECHNOLOGY CO., LTD.

No. 3, Industrial 2nd Rd., Ping-Chen Industrial District,  
Taoyuan, 324, Taiwan, R.O.C.

TEL: 886-3-4690038 FAX: 886-3-4697532

E-mail: [tstsales@mail.taisaw.com](mailto:tstsales@mail.taisaw.com) Web: [www.taisaw.com](http://www.taisaw.com)

## Approval Sheet For Product Specification

Issued Date:

Product Name: SAW Resonator 303.875 MHz SMD 5X5 mm

TST Parts No.: TC0141A

Customer Parts No.: \_\_\_\_\_

Company: _____
Division: _____
Approved by : _____
Date: _____

Checked by: Vincent Liu

Approval by: Francis Chen

Date: 2003/5/13



# TAI-SAW TECHNOLOGY CO., LTD.

No. 3, Industrial 2nd Rd., Ping-Chen Industrial District,  
Taoyuan, 324, Taiwan, R.O.C.

TEL: 886-3-4690038 FAX: 886-3-4697532

E-mail: [tstsales@mail.taisaw.com](mailto:tstsales@mail.taisaw.com) Web: [www.taisaw.com](http://www.taisaw.com)

## SAW Resonator 303.875 MHz

MODEL NO.: TC0141A

REV. NO.:1

### A. FEATURES:

- 1-Port Resonator.

### B. MAXIMUM RATING:

1. Input Power Level: 0 dBm
2. DC voltage: 12 V
3. Operating Temperature: -40°C to +85°C
4. Storage Temperature: -40°C to +85°C

RoHS Compliant  
Lead free  
Lead-free soldering

### C. ELECTRICAL CHARACTERISTICS:

Characteristic	Units	Minimum	Typical	Maximum
Center frequency <b>Fr</b>	<b>MHz</b>	303.800	303.875	303.950
Insertion Loss <b>IL</b>	<b>dB</b>		1.5	2.5
Unloaded Quality factor		6000		
Equivalent Elements				
Motional capacitance <b>C1</b>	<b>fF</b>	-	2.865	-
Motional inductance <b>L1</b>	<b>μH</b>	-	95.553	-
Motional resistance <b>R1</b>	<b>Ohm</b>	-	17.095	-
Parallel capacitance <b>Co</b>	<b>pF</b>	-	4.75	-
Temp.coeff.	<b>ppm/c*2</b>	-	0.032	-
Turnover To	<b>deg.C</b>	20	40	50
Package size		SMD 5X5X1.4mm		

### D. OUTLINE DRAWING:

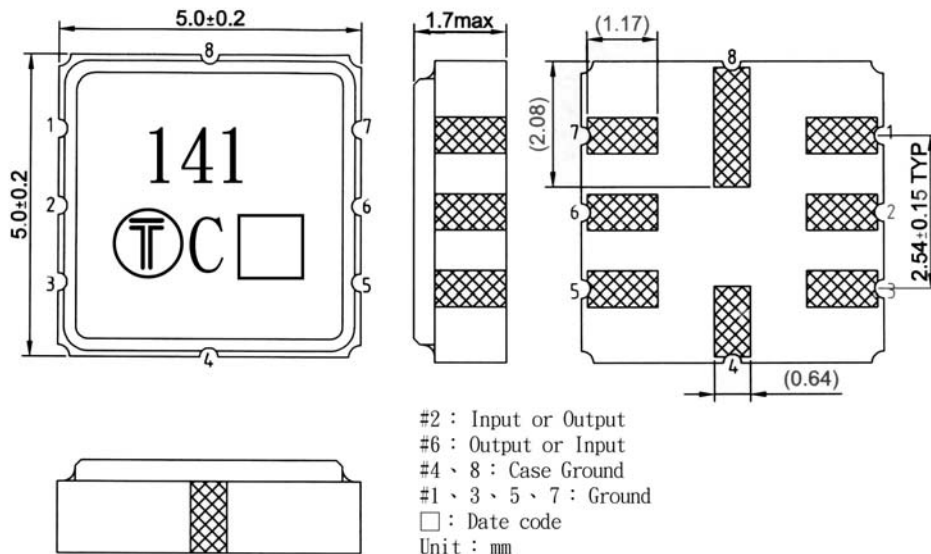

E. EQUIVALENT CIRCUIT:

One-Port Resonator:

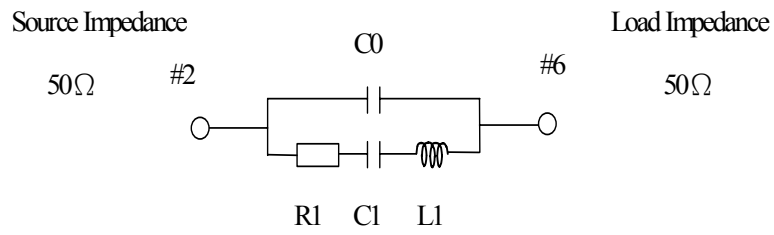

F. FREQUENCY CHARACTERISTICS:

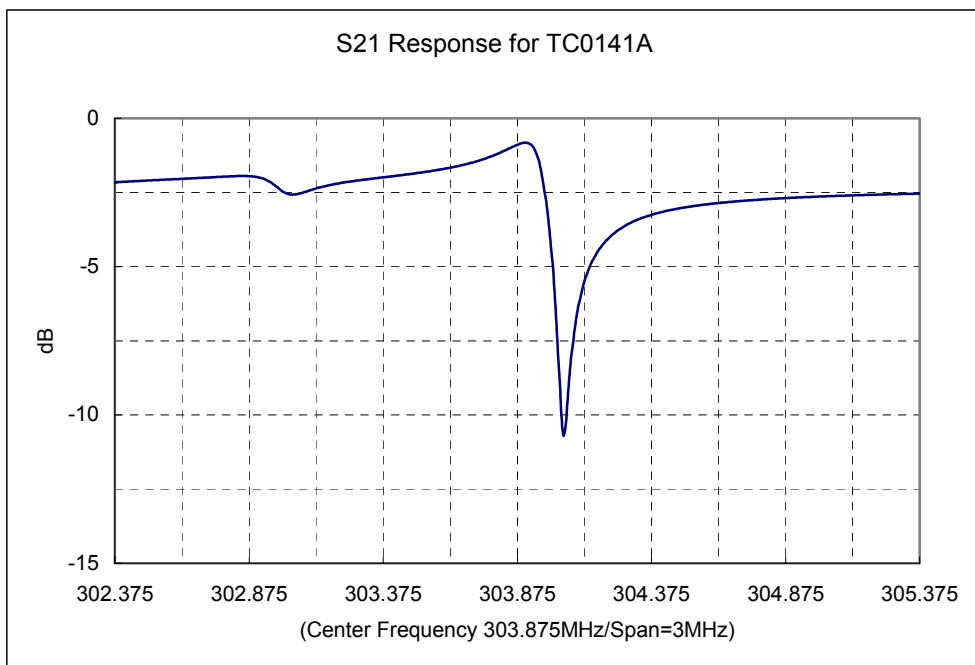

G. TEST CIRCUIT:

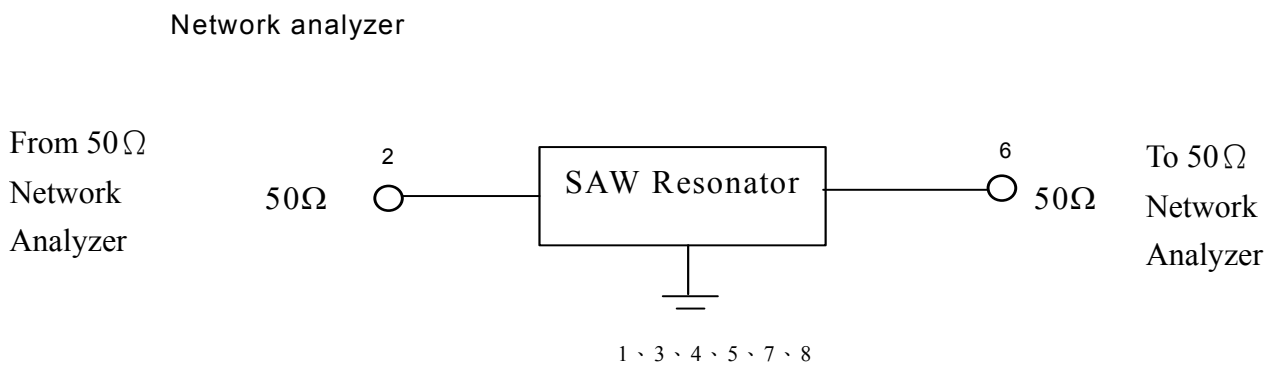

H. PACKING:

1. REEL DIMENSION

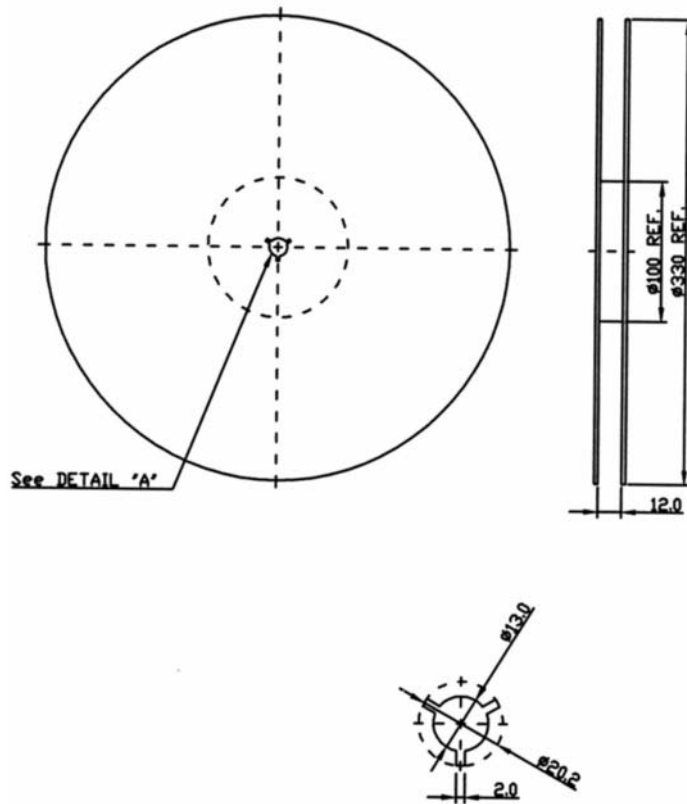

2. TAPE DIMENSION

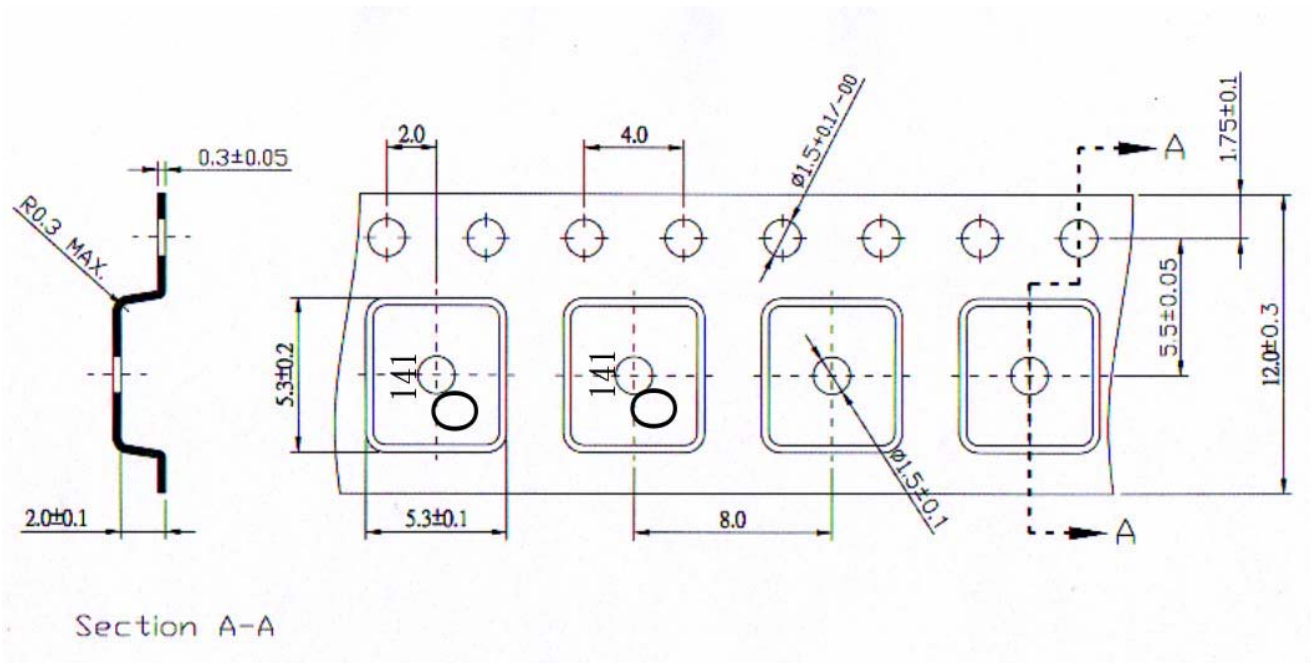

Section A-A