



TAI-SAW TECHNOLOGY CO., LTD.

No. 3, Industrial 2nd Rd., Ping-Chen Industrial District,
Taoyuan, 324, Taiwan, R.O.C.

TEL: 886-3-4690038 FAX: 886-3-4697532

E-mail: tstsales@mail.taisaw.com Web: www.taisaw.com

Product Specifications Approval Sheet

Product Description: SAW DPX 897.5/942.5MHz LET Band 8 SMD 2016

TST Part No.: TF0093A

Customer Part No.: _____

Customer signature required
Company: _____
Division: _____
Approved by : _____
Date: _____

Checked by: _____ Nina Chen *Nina Chen*

Approved by: _____ Kazuma Lee *Kazuma Lee*

Date: _____ 2023/05/31

1. Customer signed back is required before TST can proceed with sample build and receive orders.
2. Orders received without customer signed back will be regarded as agreement on the specifications.
3. Any specifications changes must be approved upon by both parties and a new revision of specifications shall be released to reflect the changes



TAI-SAW TECHNOLOGY CO., LTD.

No. 3, Industrial 2nd Rd., Ping-Chen Industrial District,
Taoyuan, 324, Taiwan, R.O.C.

TEL: 886-3-4690038 FAX: 886-3-4697532

E-mail: tstsales@mail.taisaw.com Web: www.taisaw.com

SAW DPX 897.5/942.5MHz LET Band 8 SMD 2016 (=35MHz BW)

MODEL NO.: TF0093A

REV. No.: 3.0

A. MAXIMUM RATING:

1. Maximum DC Voltage: 0V
2. Operating Temperature: -20°C to +85°C
3. Storage Temperature: -40°C to +85°C
4. Package type: C45
5. Moisture Sensitivity Level: Level 1
6. ESD 100V(MM) 200V(HBM)

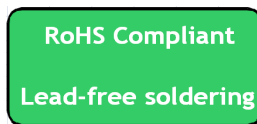

Electrostatic Sensitive Device (ESD)

B. ELECTRICAL CHARACTERISTICS:

Terminating impedance(Tx Port): 50 Ω (Single-ended)

Terminating impedance(Rx Port): 50 Ω (Single-ended)

Terminating impedance(Ant Port): 50//7.5nH Ω (Single-ended)

Tx to ANT

Parameters Description		Unit	Mini.	Typical	Max.
Insertion Loss	880.24 ~ 914.76 MHz	dB	-	2.1	3.2
Amplitude Ripple	882.4 ~ 912.6 MHz	dB	-	1.9	2.4
VSWR	ANT	-	-	1.1	2.8
	Tx	-	-	1.7	2.1
Input Power	880.0 ~ 915.0 MHz	dBm	+29dBm, Ta=+50°C 10kh, WCDMA modulation		
Attenuation:					
10.0 ~ 728.0 MHz		dB	35	38	-
728.0 ~ 798.0 MHz		dB	30	38	-
927.4 ~ 957.6 MHz		dB	44	54	-
1565.0 ~ 1607.0 MHz		dB	45	47	-
1710.0 ~ 2170.0 MHz		dB	45	50	-
2400.0 ~ 2745.0 MHz		dB	40	46	-
5130.0 ~ 5825.0 MHz		dB	12	20	-

ANT to Rx

Parameters Description		Unit	Mini.	Typical	Max.
Insertion Loss	925.0 ~ 960.0 MHz	dB	-	2.1	2.9
	927.4 ~ 957.6 MHz		-	2.0	2.4
Amplitude Ripple	925.0 ~ 960.0 MHz	dB _{p-p}	-	1.0	2.2
VSWR	ANT	-	1.6	2.3	2.0
	Rx	-	1.9	2.3	2.0
Attenuation:					
699.0 ~ 798.0 MHz		dB	45	60	-
882.4 ~ 912.6 MHz		dB	50	55	-
1045.0 ~ 2880.0 MHz		dB	40	49	-

Tx to Rx

Isolation	882.4 ~ 912.6 MHz	dB	55	57	-
	915.0 ~ 925.0 MHz	dB	16	20	
	927.4 ~ 957.6 MHz	dB	51	55	-

Notes: (1) With Matching Network .

C. Frequency Characteristics:

Tx to Ant

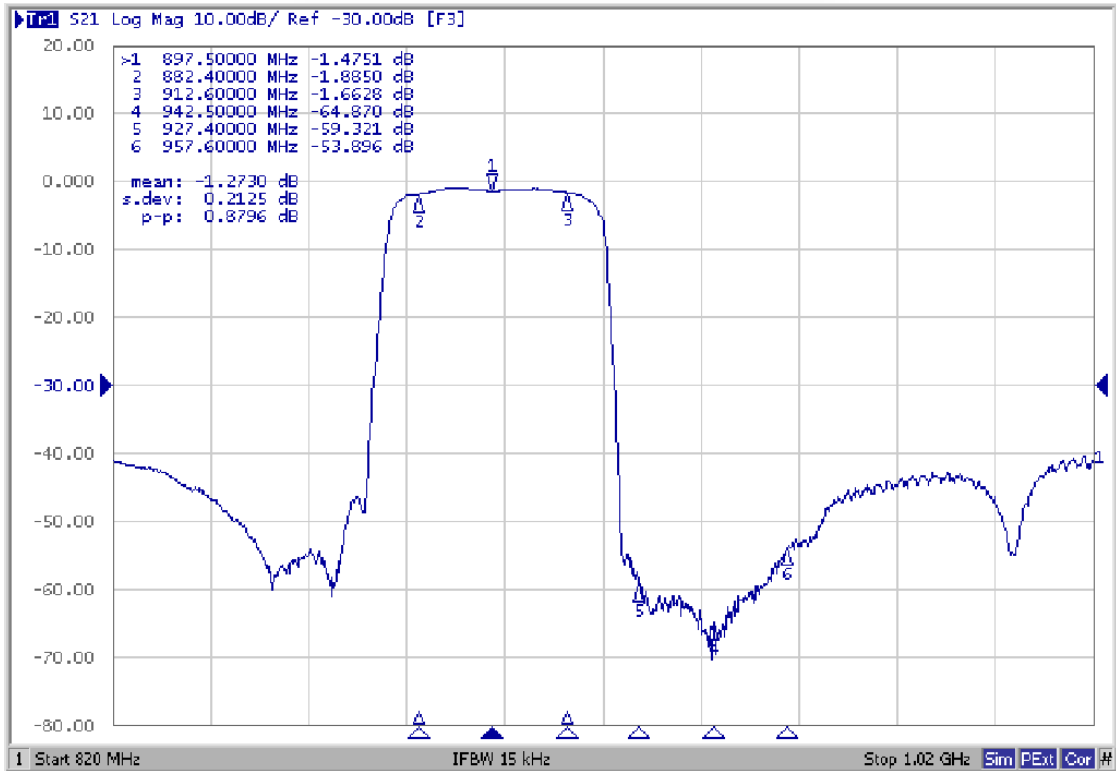

Ant to Rx

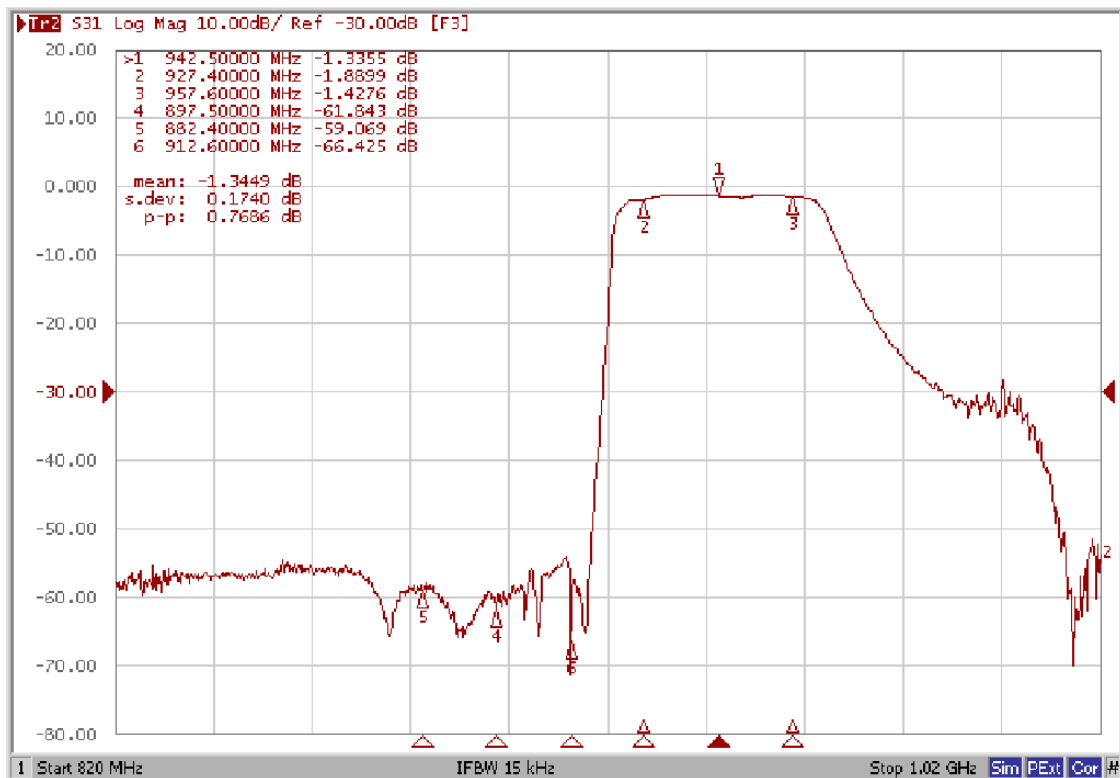

Isolation

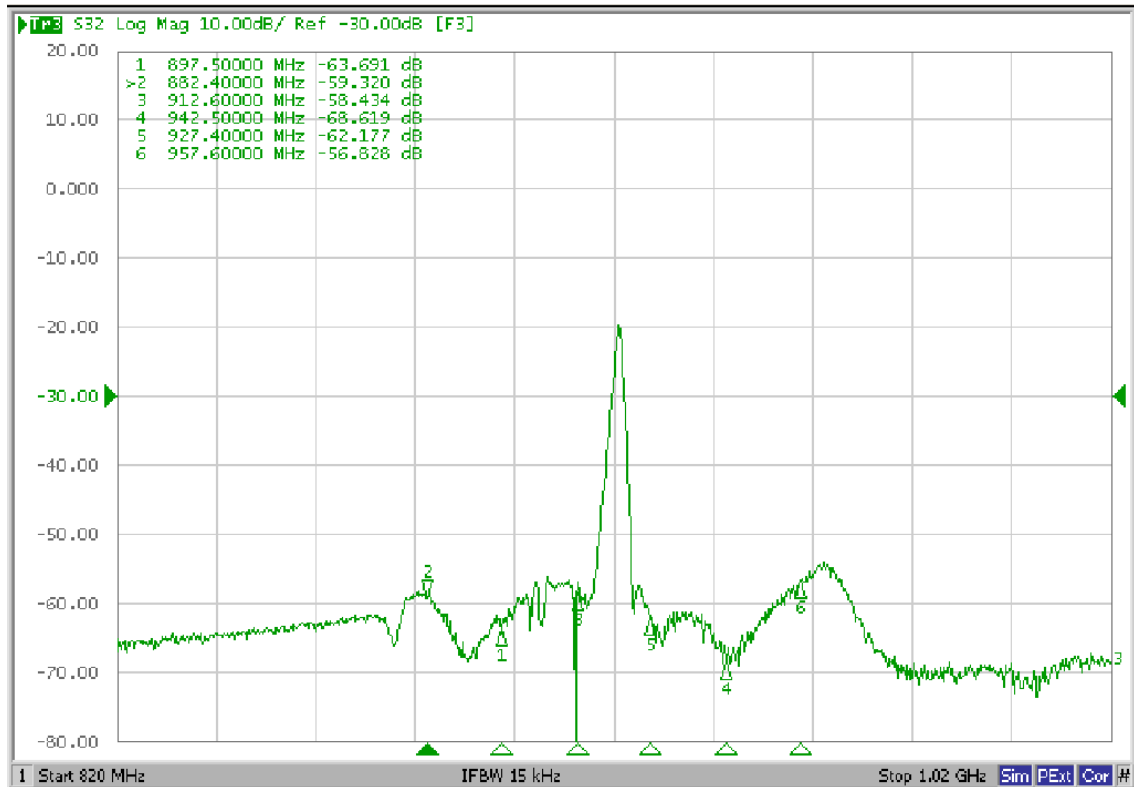

Ripple

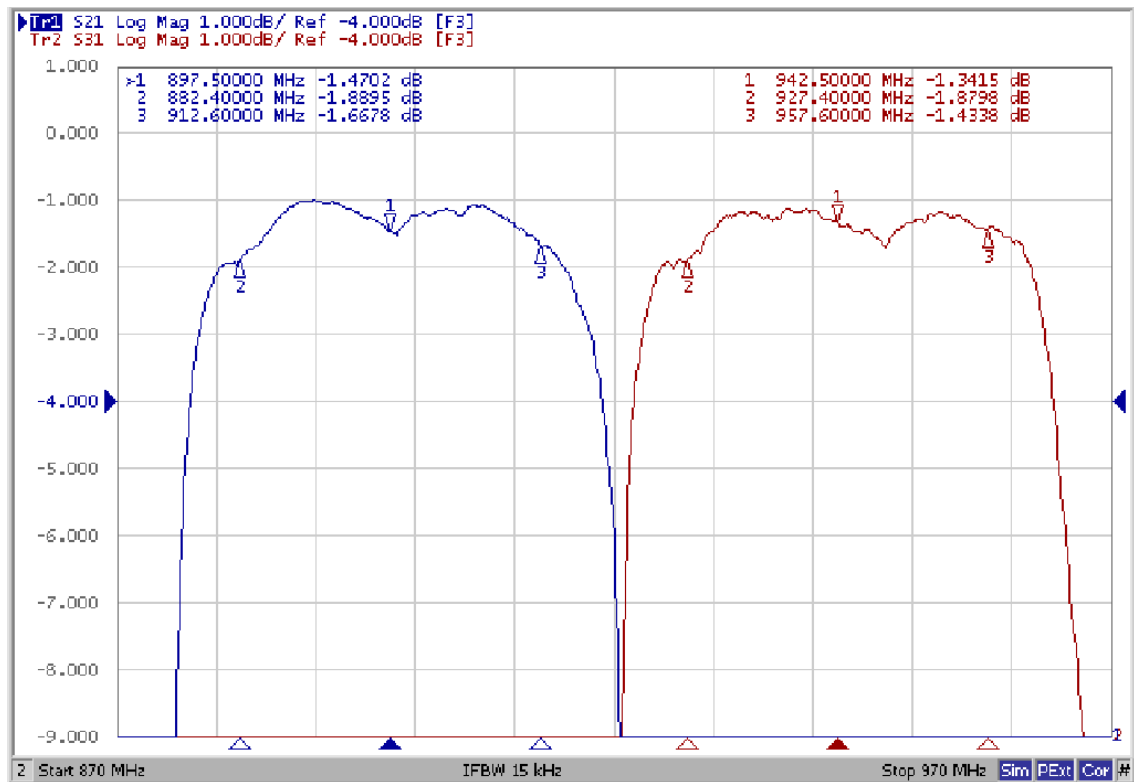

VSWR (Tx Port)

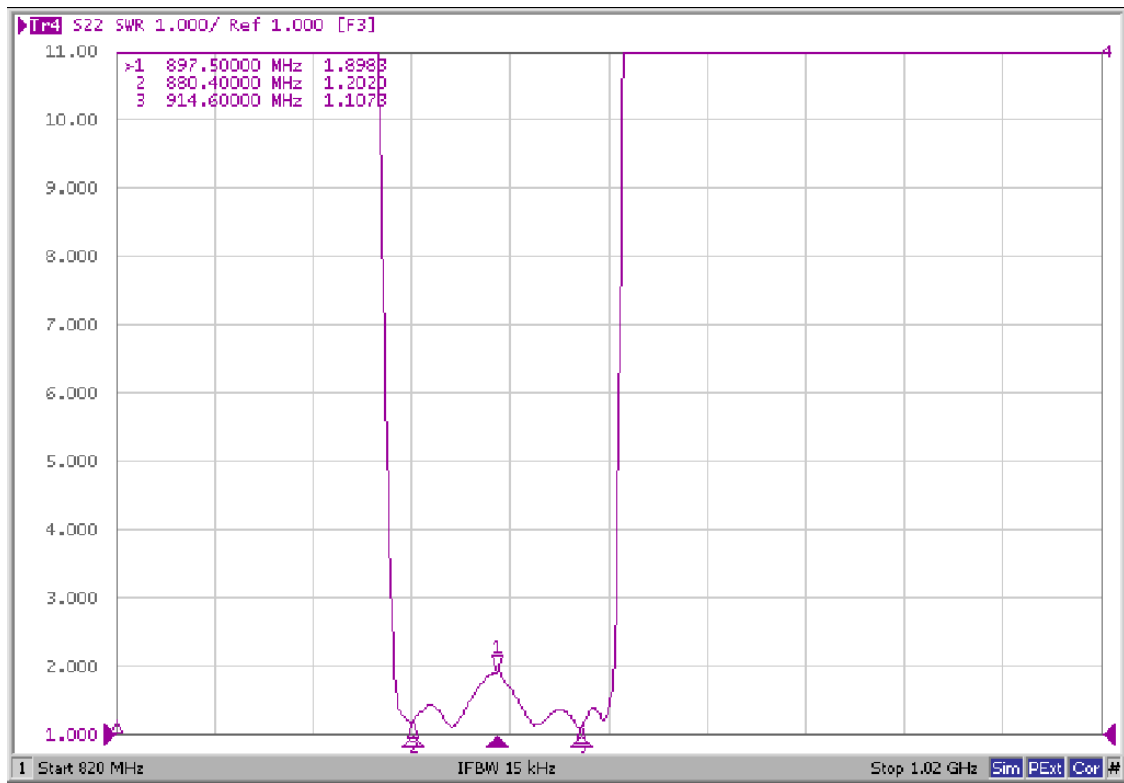

Smith Chart (Tx Port)

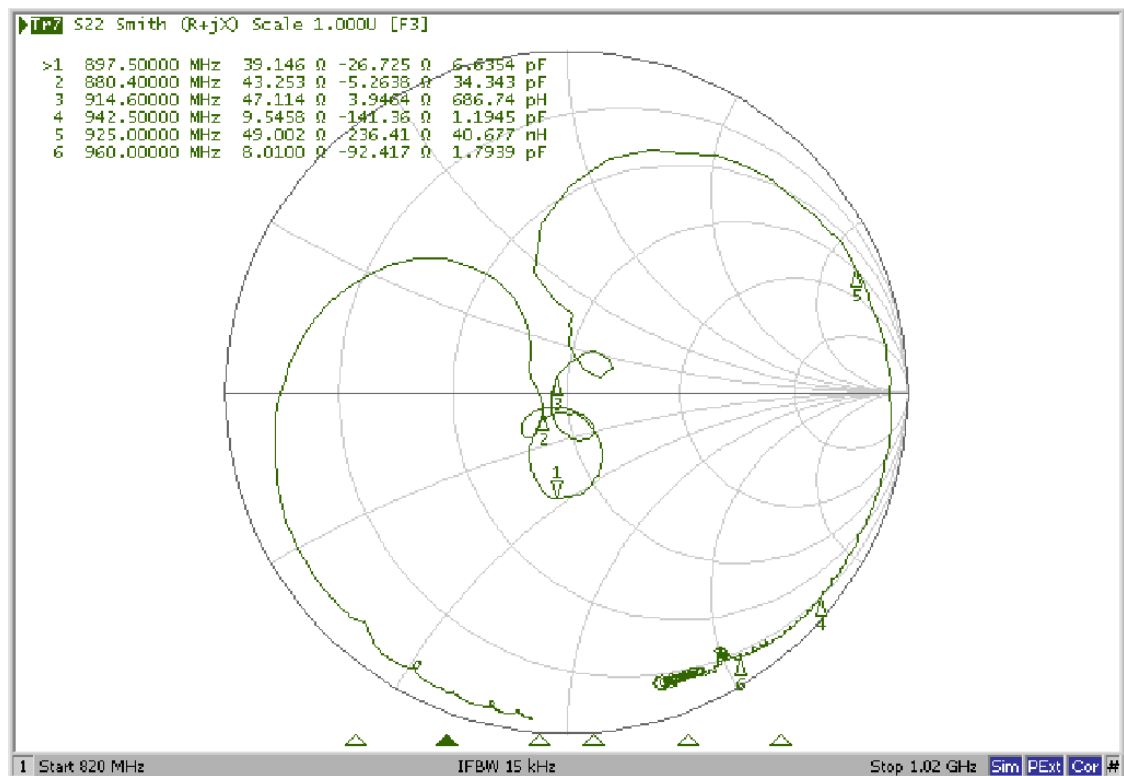

VSWR (Rx Port)

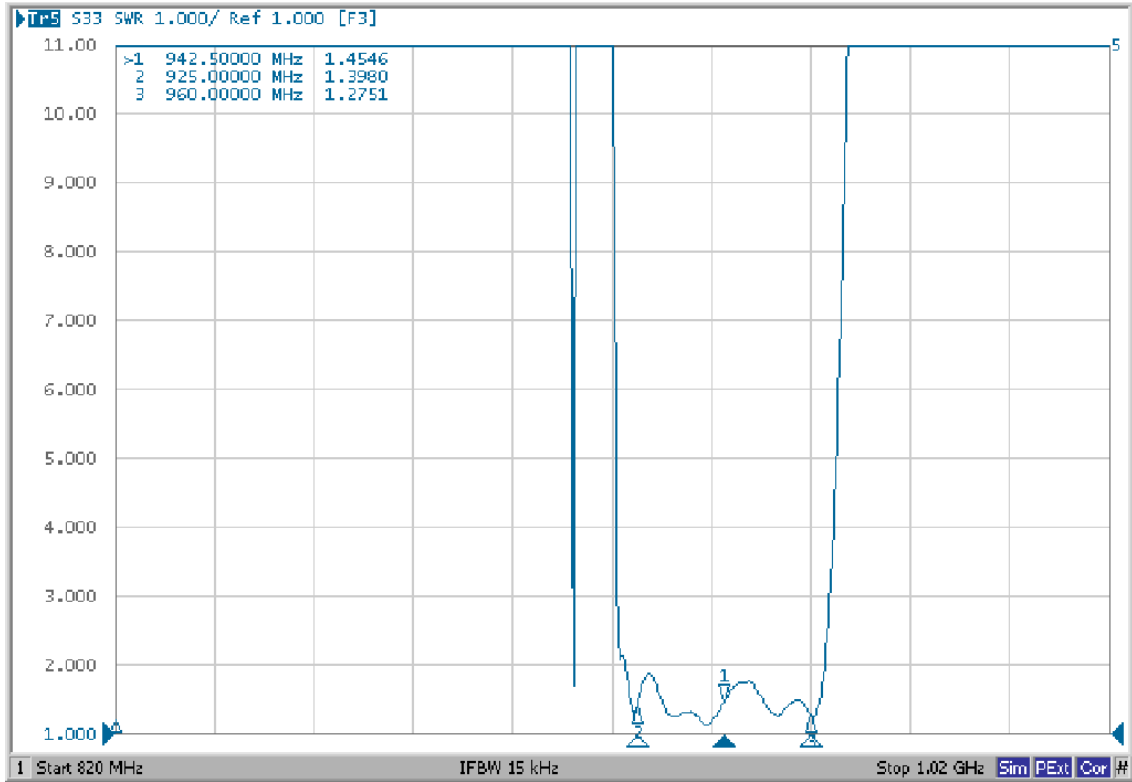

Smith Chart (Rx Port)

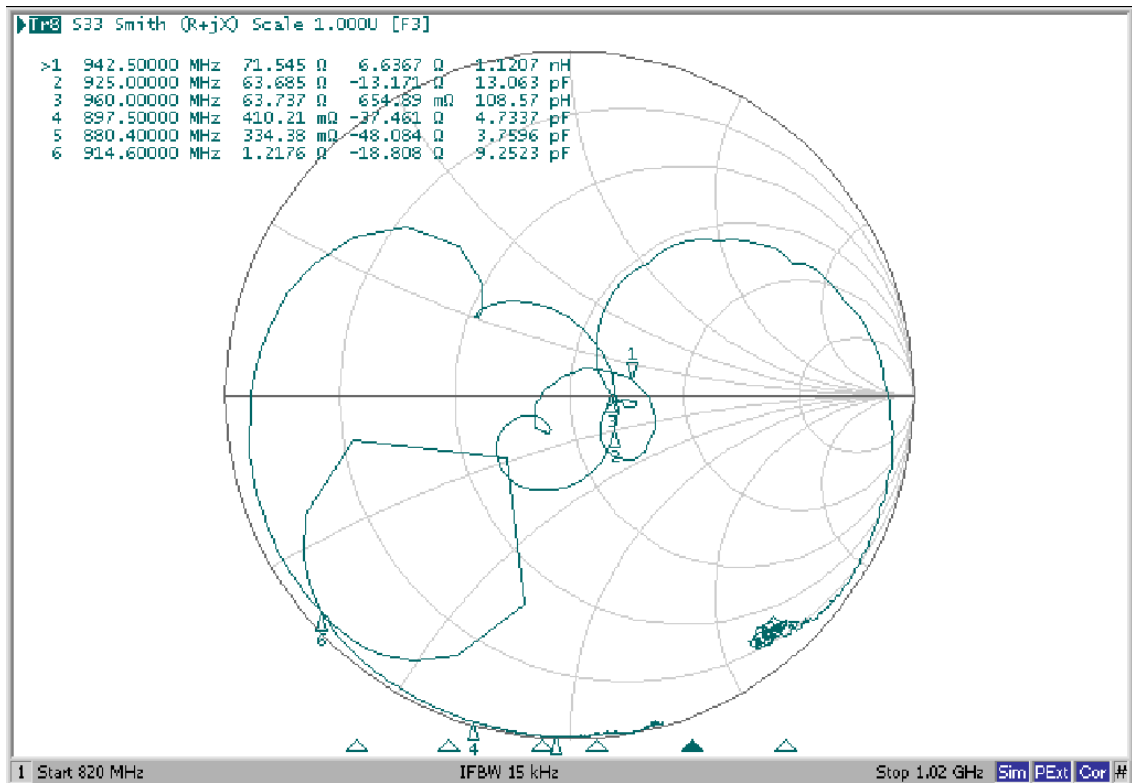

SWR (ANT Port)

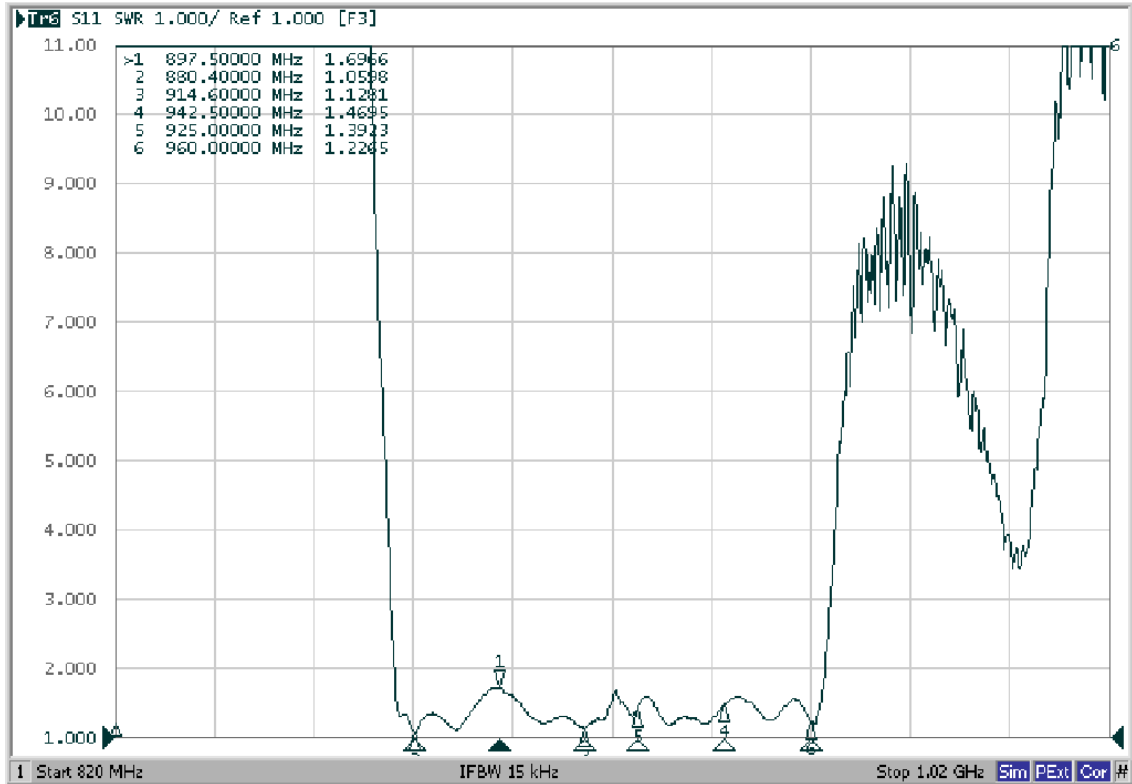

Smith Chart (ANT Port)

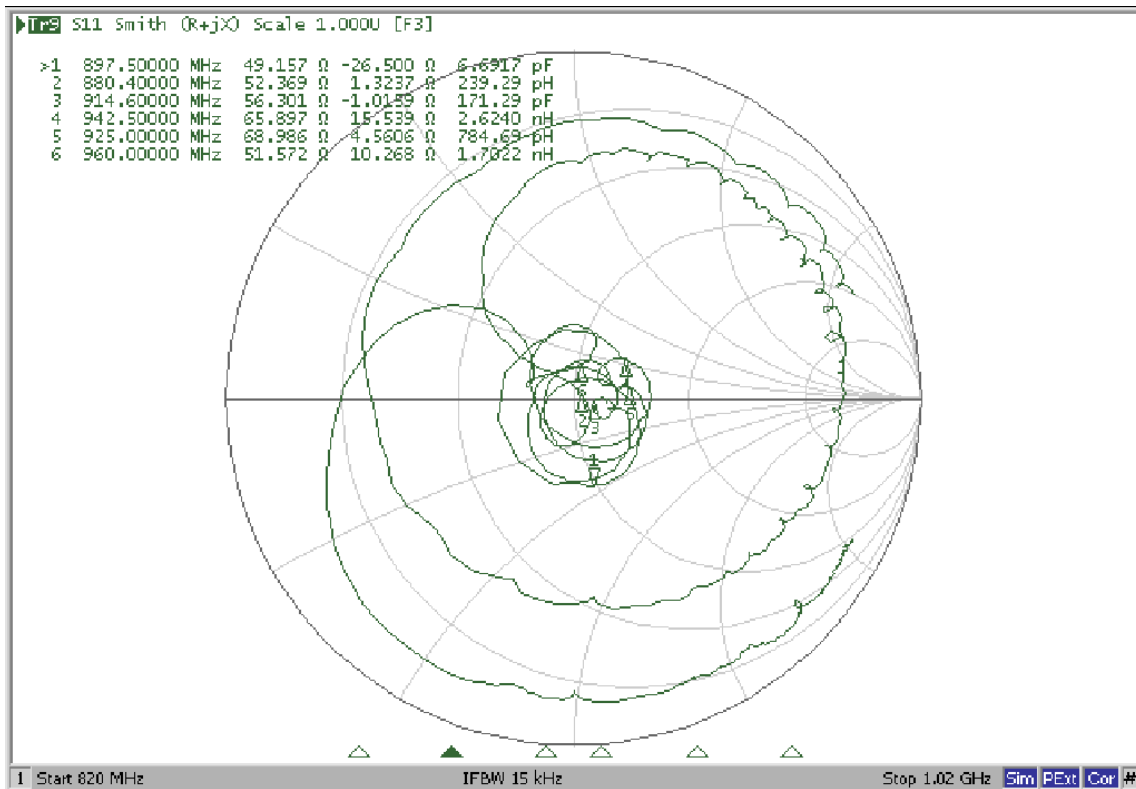

Wide Span

Tx

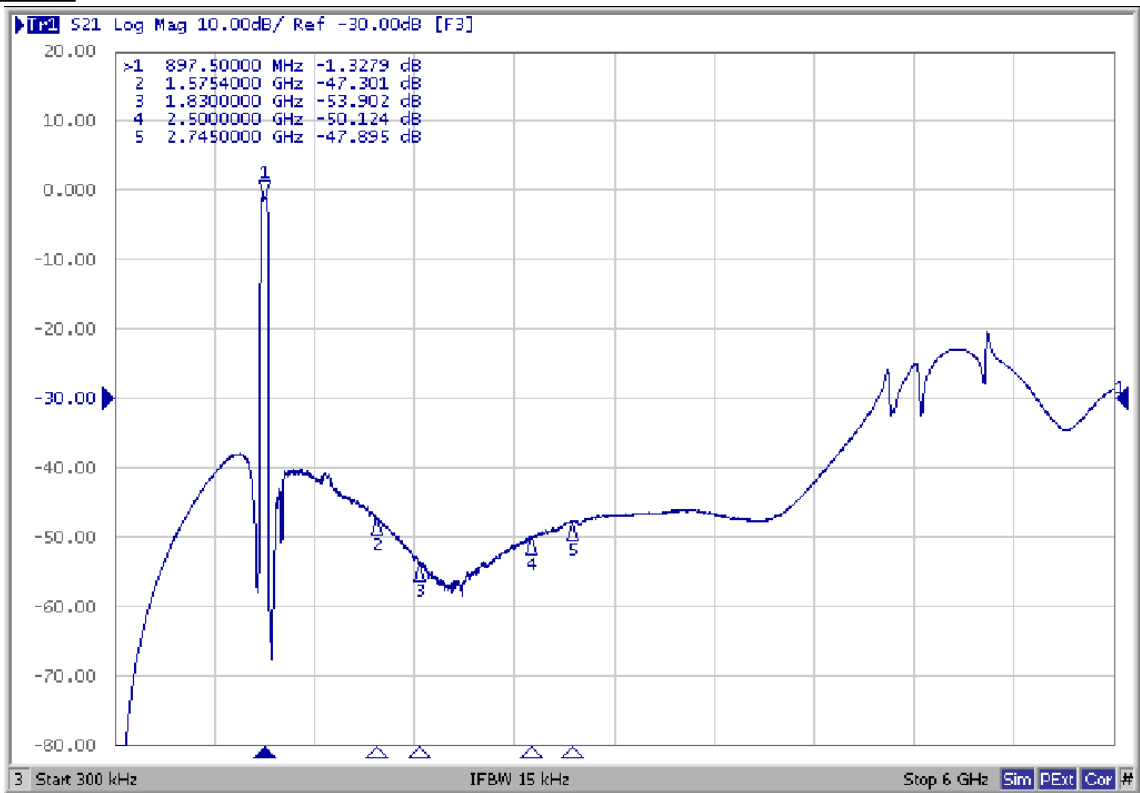

Rx

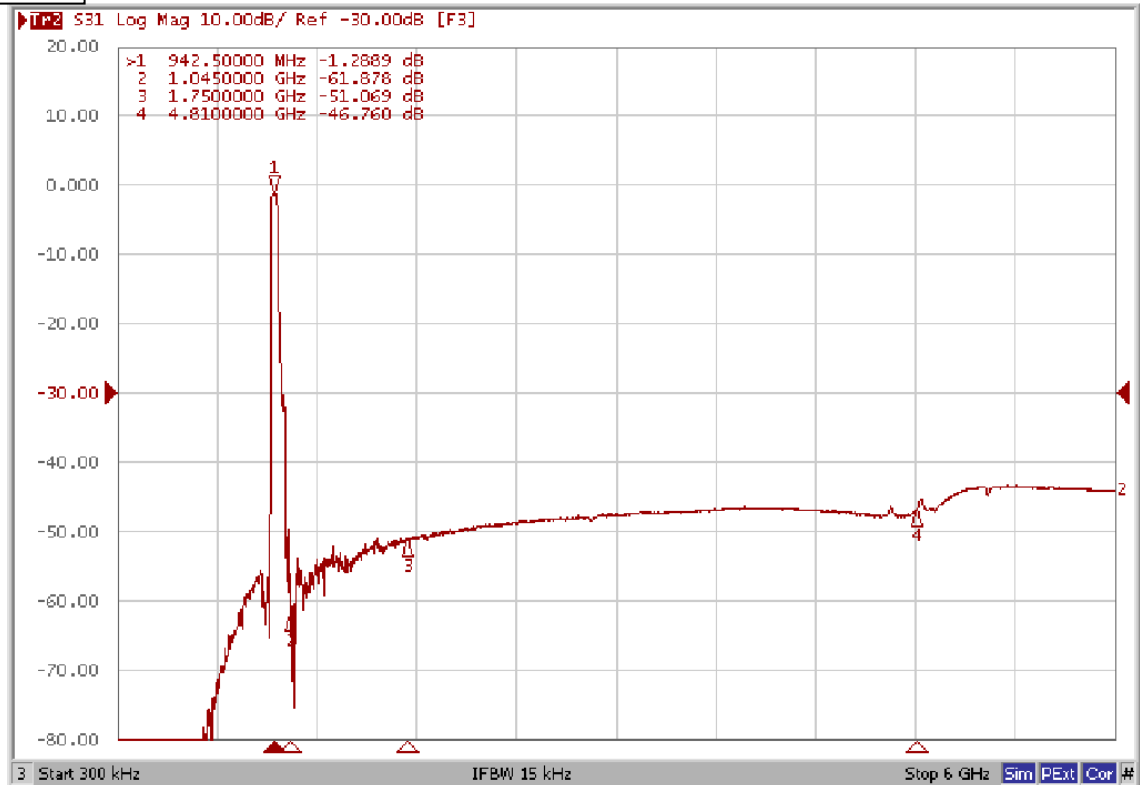

D. MEASUREMENT CIRCUIT:

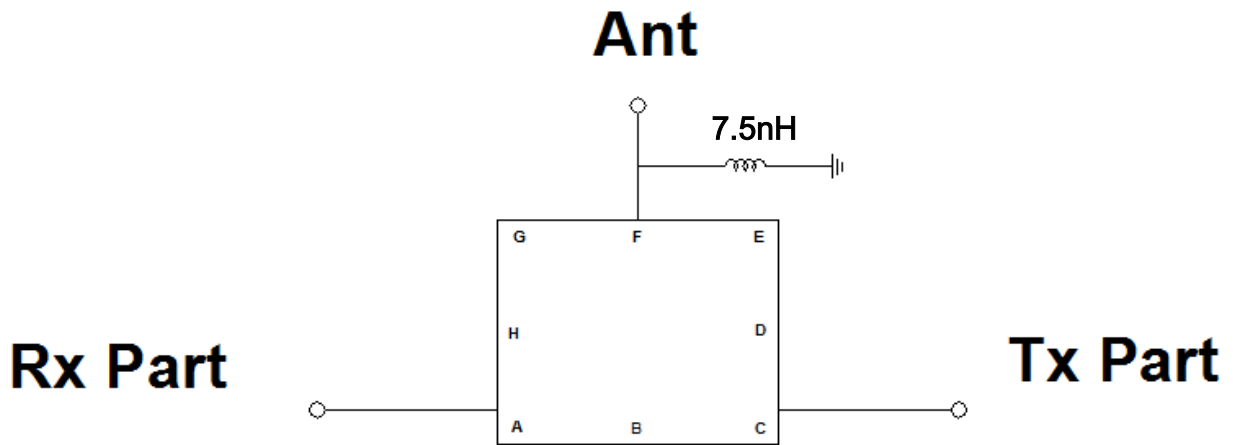

E. OUTLINE DRAWING:

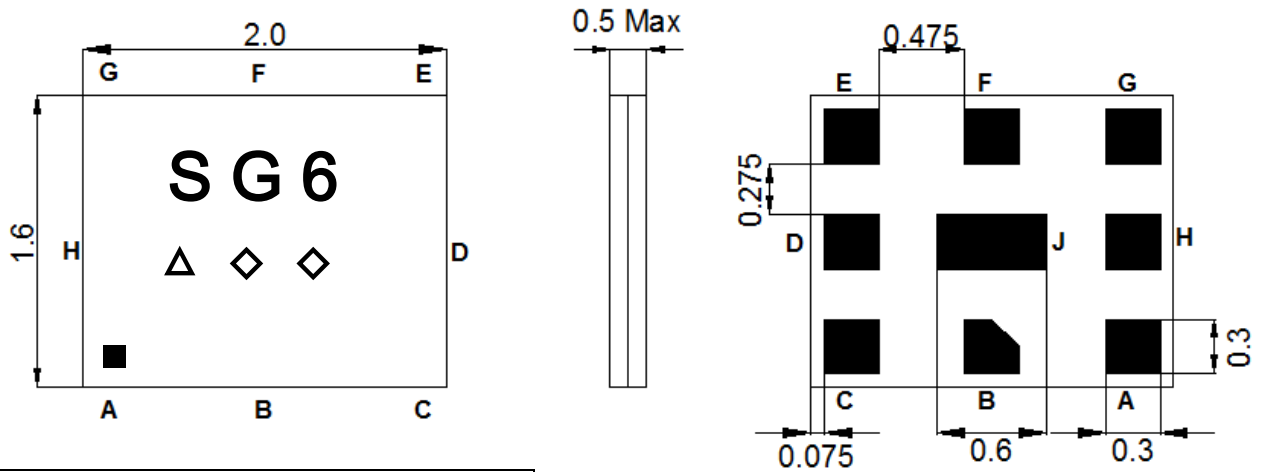

Pin Description	
B,D,E,G,H	Ground
F	Ant
C	Tx (897.5MHz)
A	Rx (942.5MHz)

Marking name : **SG6**

△: Date code(2020 May → s ,....., 2027 Dec→m.)

◇◇: Lot Code.

Product Date Code. Follow below table.

Year	Jan	Feb	Mar	Apr	May	Jun	Jul	Aug	Sep	Oct	Nov	Dec
2020/2024	n	p	q	r	s	t	u	v	w	x	y	z
2021/2025	A	B	C	D	E	F	G	H	J	K	L	M
2022/2026	N	P	Q	R	S	T	U	V	W	X	Y	Z
2023/2027	a	b	c	d	e	f	g	h	j	k	l	m

F. Packing:

1. REEL DIMENSION

(Please refer to FR-75D10 for packing quantity)

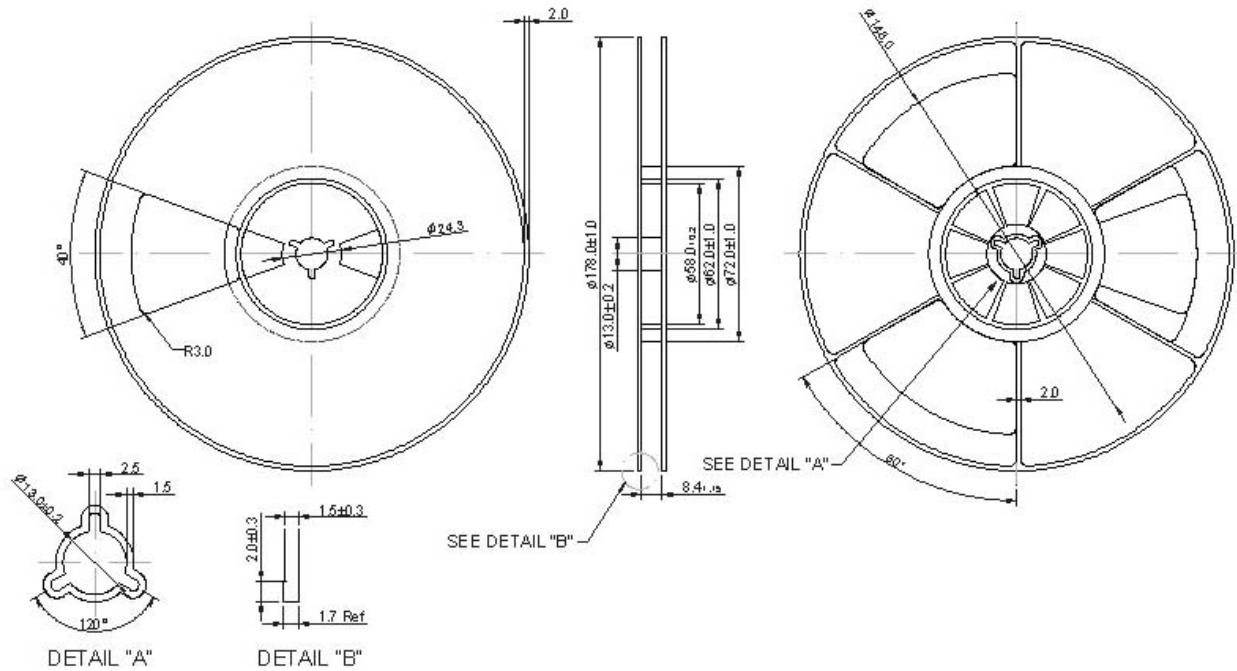

2. TAPE DIMENSION

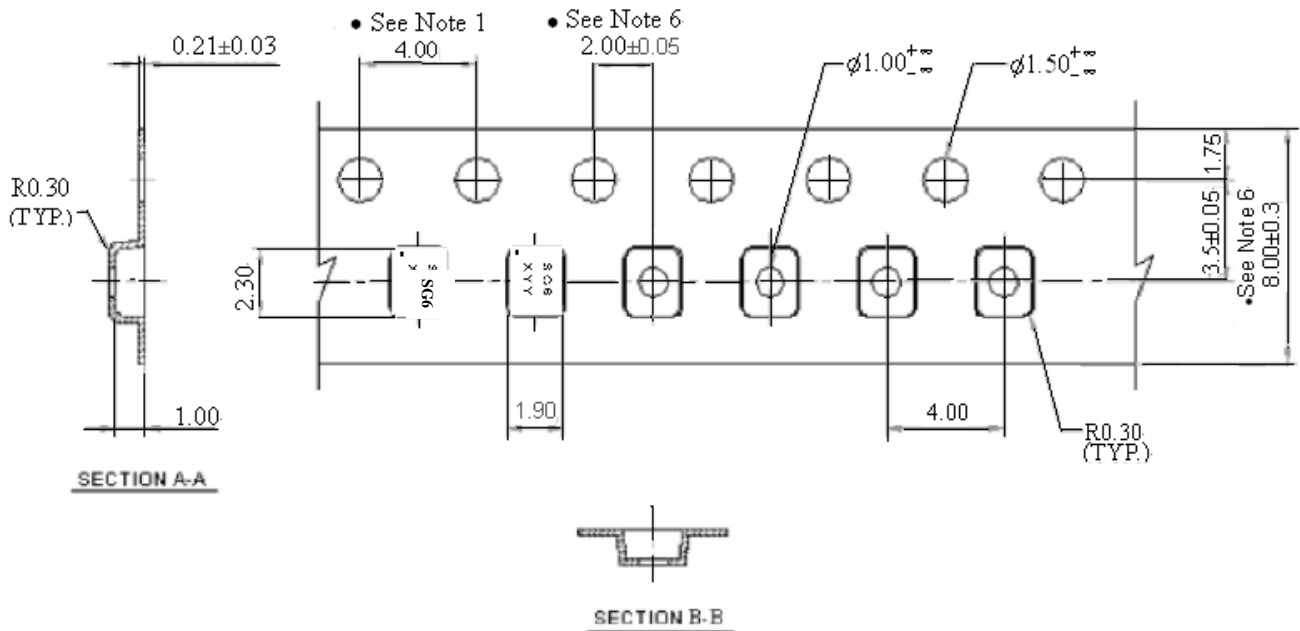

G. Recommended Reflow Profile:

1. Preheating shall be fixed at 150~180°C for 60~90 seconds.
2. Ascending time to preheating temperature 150°C shall be 30 seconds min.
3. Heating shall be fixed at 220°C for 50~80 seconds and at 245~260°C peak (min. 10sec).
4. Time : 2 times.

