



# TAI-SAW TECHNOLOGY CO., LTD.

No. 3, Industrial 2nd Rd., Ping-Chen Industrial District,  
Taoyuan, 324, Taiwan, R.O.C.

TEL: 886-3-4690038 FAX: 886-3-4697532

E-mail: [tstsales@mail.taisaw.com](mailto:tstsales@mail.taisaw.com) Web: [www.taisaw.com](http://www.taisaw.com)

## Product Specifications Approval Sheet

Product Name: SAW DPX 1880/1960 MHz Band 2 SMD 2.0x1.6 mm (BW=60 MHz)

TST Parts No.: TF0105A

Customer Part No.: \_\_\_\_\_

Customer signature required
Company: _____
Division: _____
Approved by : _____
Date: _____

Checked by: \_\_\_\_\_ Hayley Chou *Hayley Chou*

Approved by: \_\_\_\_\_ Andy Yu *Andy Yu*

Date: \_\_\_\_\_ 2019/09/18

1. Customer signed back is required before TST can proceed with sample build and receive orders.
2. Orders received without customer signed back will be regarded as agreement on the specifications.
3. Any specifications changes must be approved upon by both parties and a new revision of specifications shall be released to reflect the changes



# TAI-SAW TECHNOLOGY CO., LTD.

No. 3, Industrial 2nd Rd., Ping-Chen Industrial District,  
Taoyuan, 324, Taiwan, R.O.C.

TEL: 886-3-4690038 FAX: 886-3-4697532

E-mail: [tstsales@mail.taisaw.com](mailto:tstsales@mail.taisaw.com) Web: [www.taisaw.com](http://www.taisaw.com)

## SAW DPX 1880/1960 MHz

MODEL NO.:TF0105A

REV. NO.:3.0

### A. MAXIMUM RATING:

1. Input Power Level (1850.4~1909.6 MHz): 29 dBm (50k hours Max.)
2. DC Voltage: +/-5 V
3. Operating Temperature: -30 °C to +85 °C
4. Storage Temperature: -40 °C to +100 °C
5. Moisture Sensitive Level: Level 1 (MSL1)
6. ESD: 50 V(MM), 100 V(HBM)

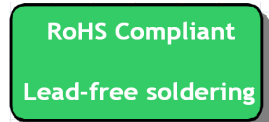

Electrostatic Sensitive Device (ESD)

### B. ELECTRICAL CHARACTERISTICS:

Terminating impedance (Tx port): 50 Ω

Terminating impedance (Rx port): 50 Ω

Terminating impedance (Ant port): 50//4.7nH Ω

#### Tx to Ant

Item	Unit	Min.	Typ.	Max.	Remark
<b>Insertion Loss</b> (1850.4~1909.6 MHz)	dB(*1)	-	2.2	3.0	-20 to +85 °C
<b>Insertion Loss</b> (1850.6~1909.4 MHz)	dB(*1)	-	2.2	3.0	-
<b>Amplitude Ripple</b> (1850.4~1909.6 MHz)	dB	-	1.1	2.0	-
<b>VSWR Ant</b> (1850.4~1909.6 MHz)	-	-	1.6	2.0	-
<b>VSWR Tx</b> (1850.4~1909.6 MHz)	-	-	1.7	2.0	-
<b>Attenuation</b> (Reference level from 0 dB)					
1570 ~ 1580 MHz	dB	40	49	-	-
1930.4 ~ 1989.6 MHz	dB	44	51	-	-20 to +85 °C
1930.6 ~ 1989.4 MHz	dB	42	51	-	-
3700 ~ 3820 MHz	dB	22	32	-	-
5550 ~ 5730 MHz	dB	15	26	-	-

### Ant to Rx

Item	Unit	Min.	Typ.	Max.	Remark
Insertion Loss (1930.4~1989.6 MHz)	dB(*1)	-	2.7	3.5	-20 to +85 °C
Insertion Loss (1930.6~1989.4 MHz)	dB(*1)	-	2.7	3.5	-
Amplitude Ripple (1930.4~1989.6 MHz)	dB	-	1.2	2.2	-
VSWR Ant (1930.4~1989.6 MHz)	-	-	1.7	2.0	-
VSWR Rx (1930.4~1989.6 MHz)	-	-	1.7	2.0	-
<b>Attenuation</b> (Reference level from 0 dB)					
1850.4 ~ 1909.6 MHz	dB	45	53	-	-20 to +85 °C
1850.6 ~ 1909.4 MHz	dB	45	53	-	-

### Tx to Rx

Item	Unit	Min.	Typ.	Max.	Remark
<b>Isolation</b> (Reference level from 0 dB)	1850.4 ~ 1909.6 MHz	dB	51	55	-20 to +85 °C
	1850.6 ~ 1909.4 MHz	dB	51	55	-
	1930.4 ~ 1989.6 MHz	dB	48	52	-20 to +85 °C
	1930.6 ~ 1989.4 MHz	dB	47	52	-

(\*1) Specification of insertion loss excludes loss that comes from the test board. (Approximately 0.15 dB)

### C. MEASUREMENT CIRCUIT:

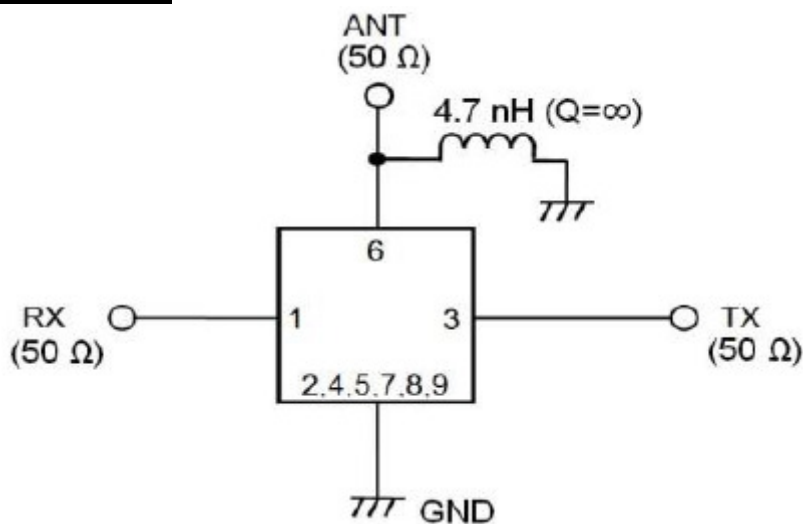

## D. FREQUENCY CHARACTERISTICS:

### Tx to Ant

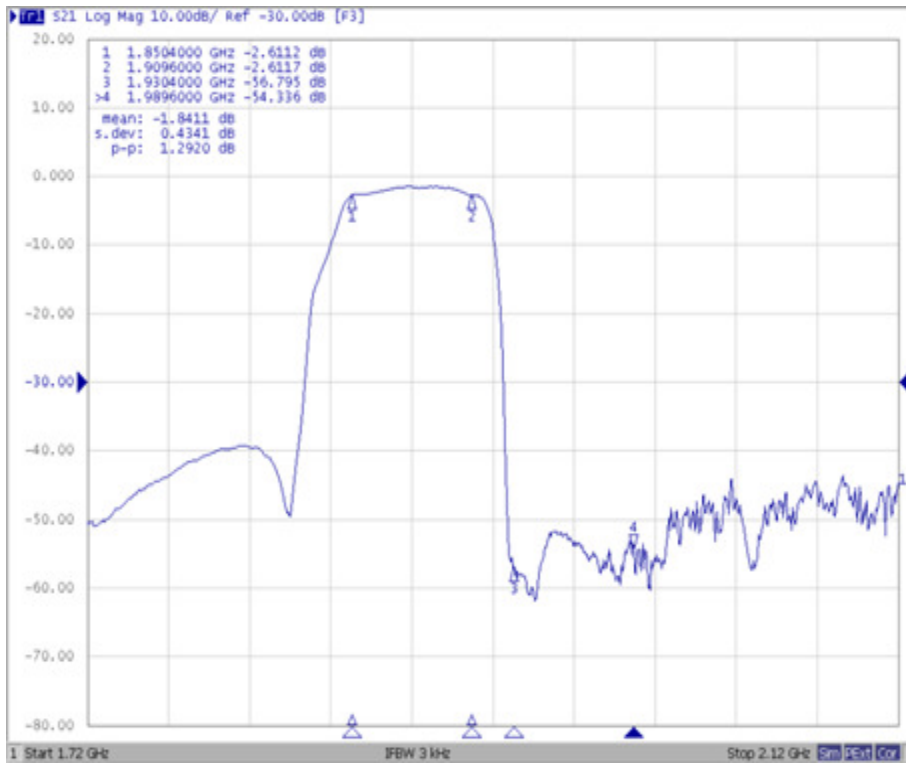

### Ant to Rx

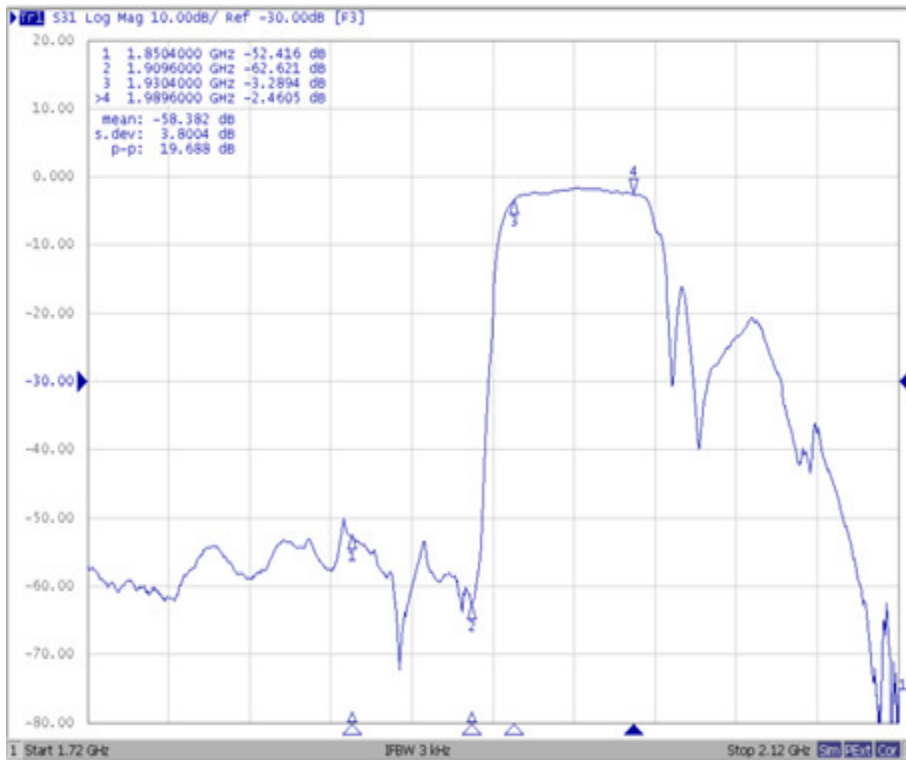

### Tx to Ant, Ant to Rx

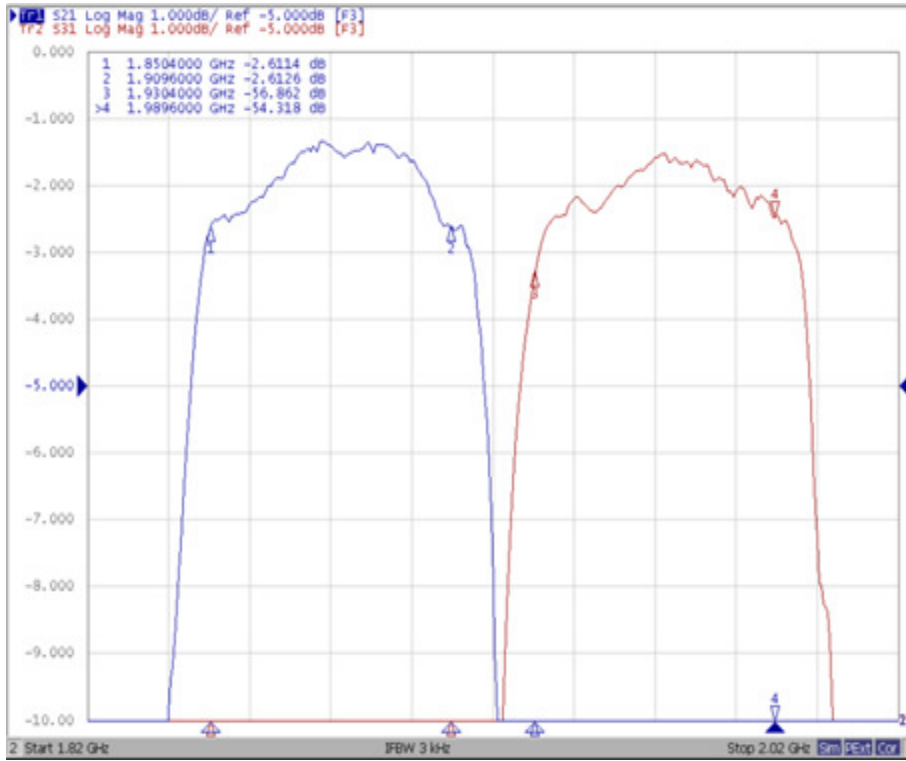

### Tx to Rx Isolation

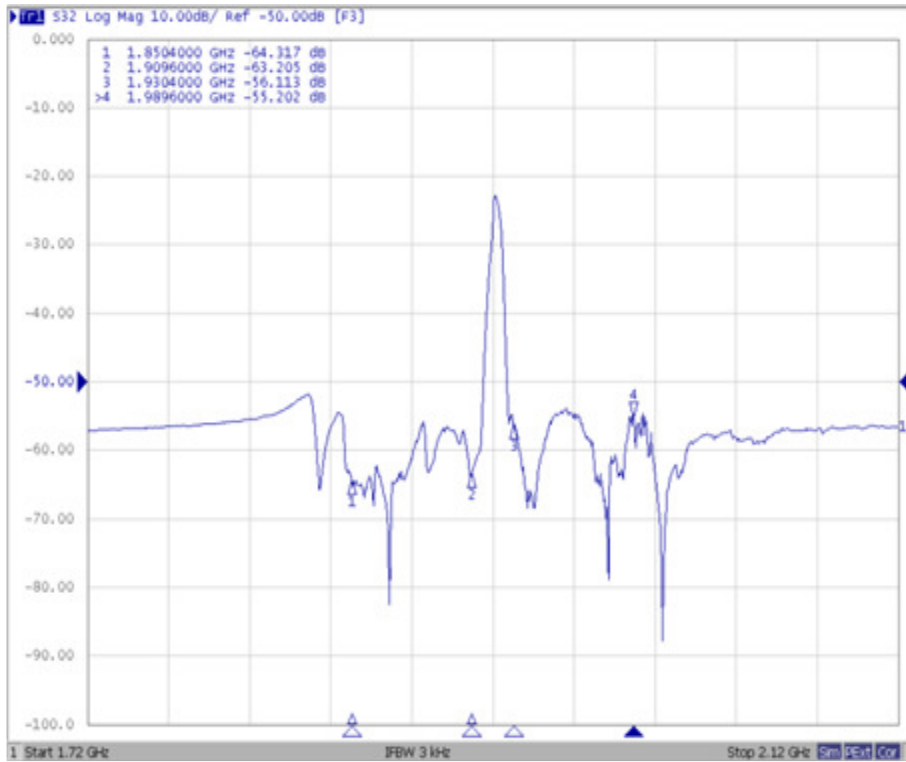

## Tx Port

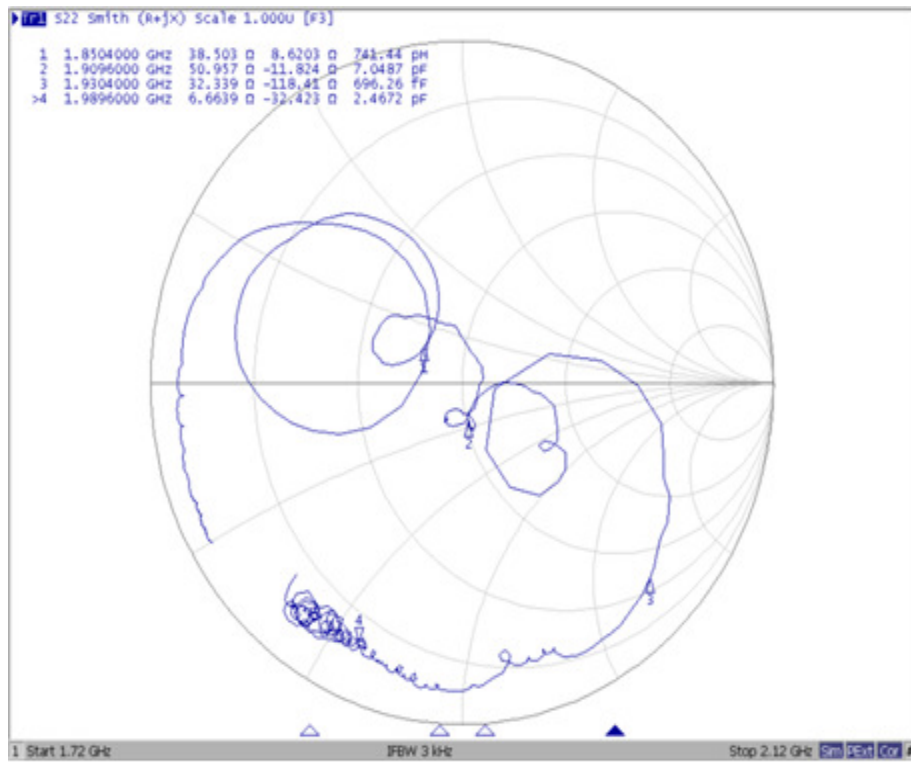
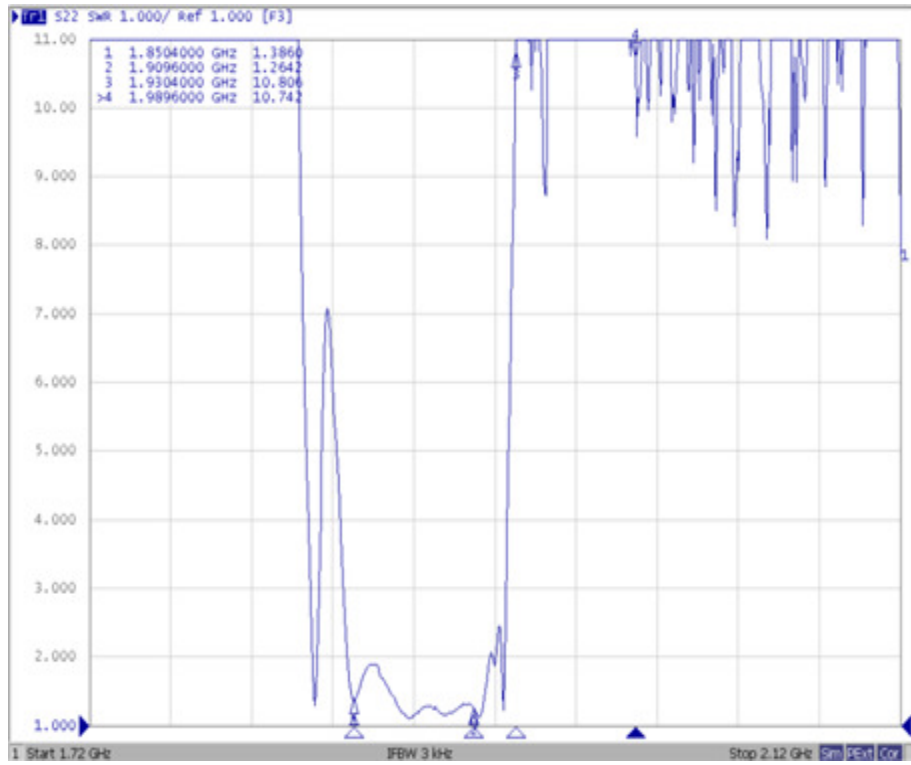

## Rx Port

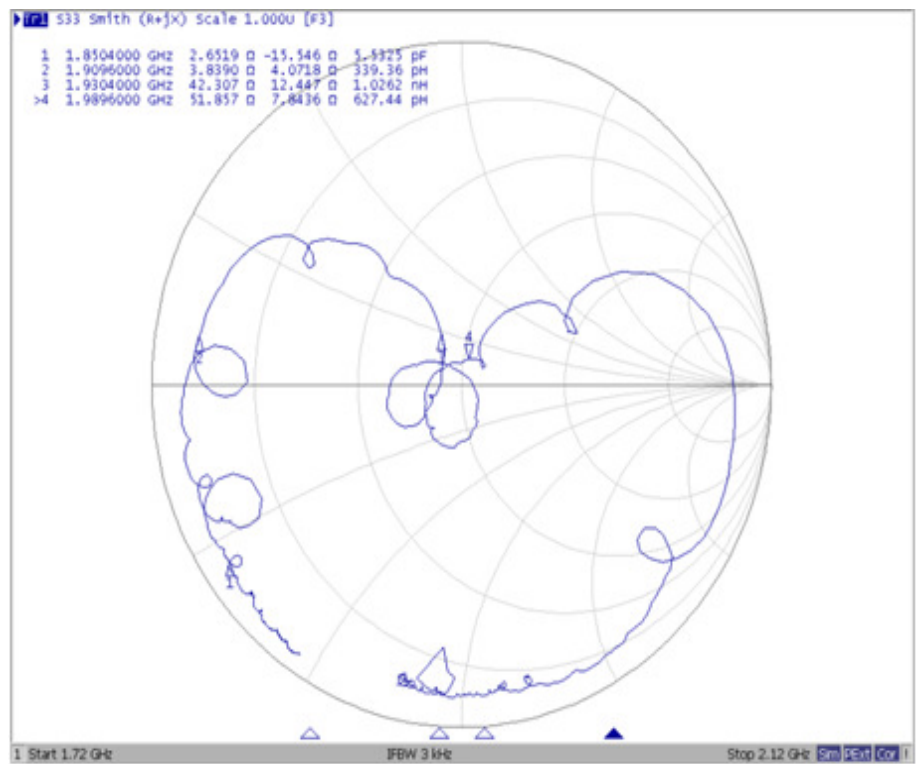
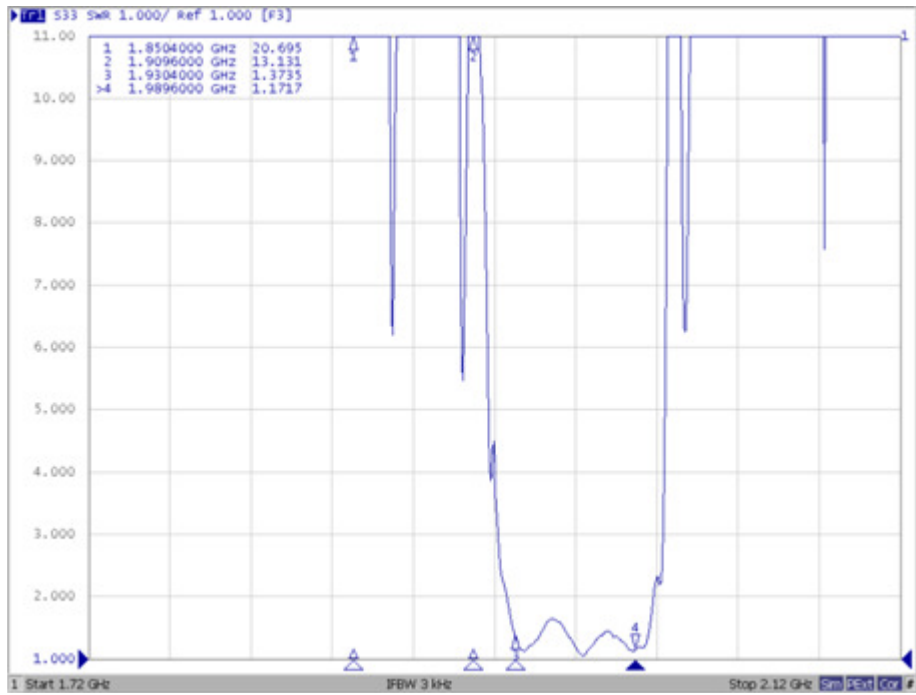

## Ant Port

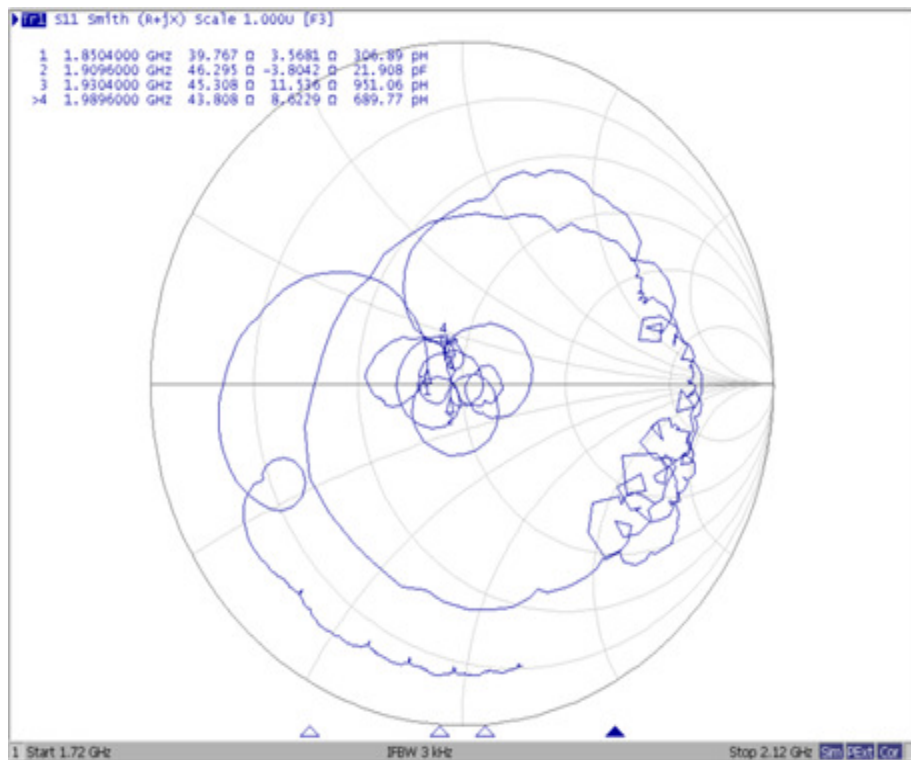
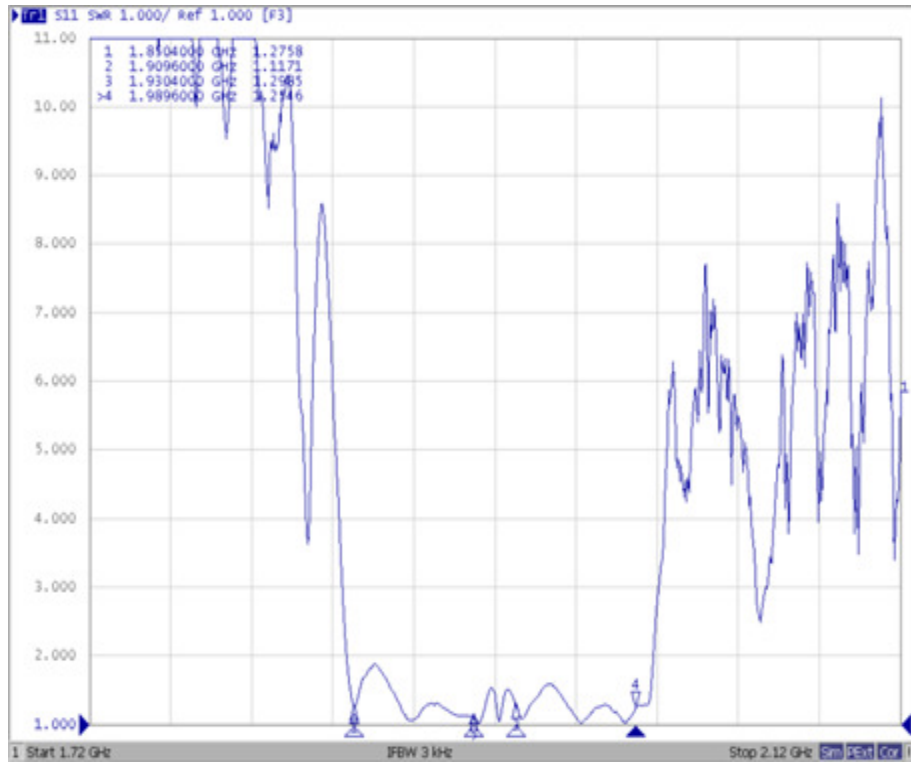



### Tx to Ant (Wide span)

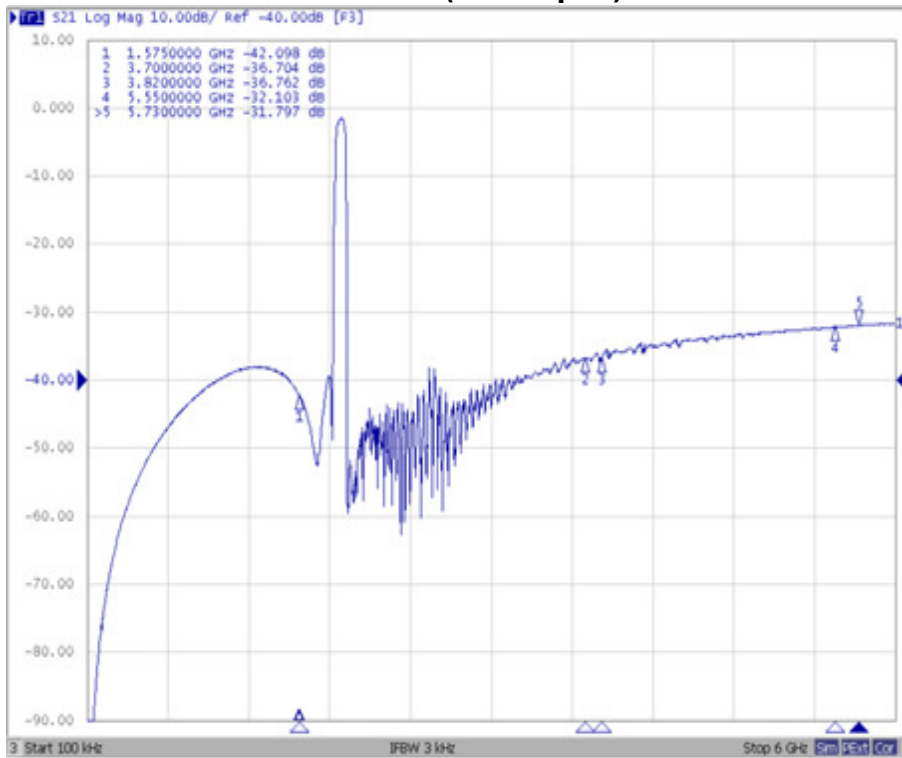

### Ant to Rx (Wide span)

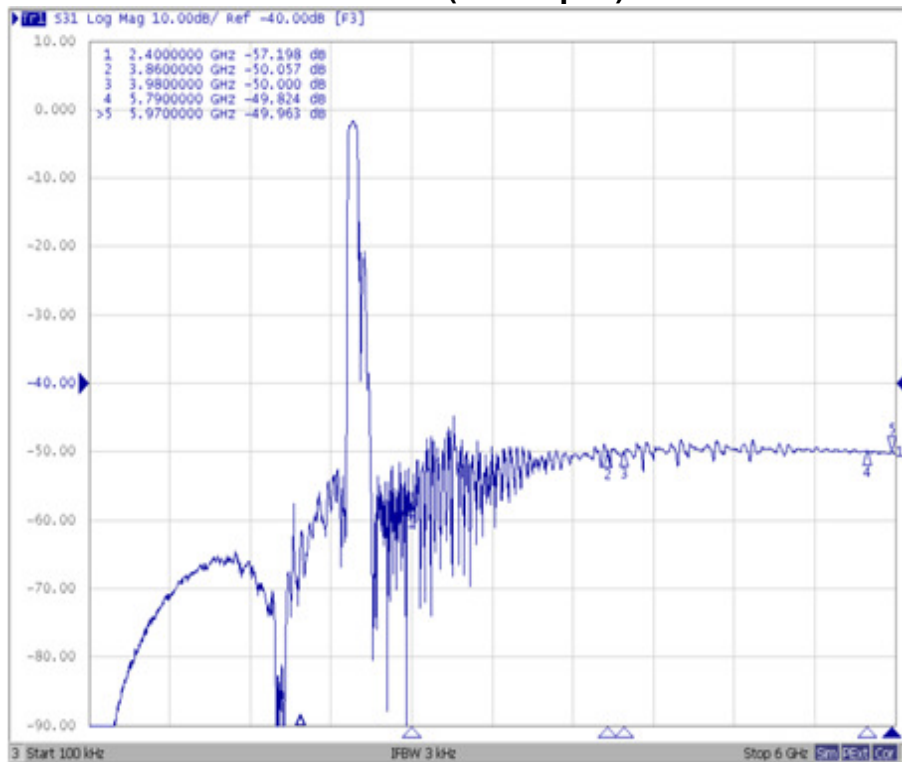

**E. PCB Footprint:**

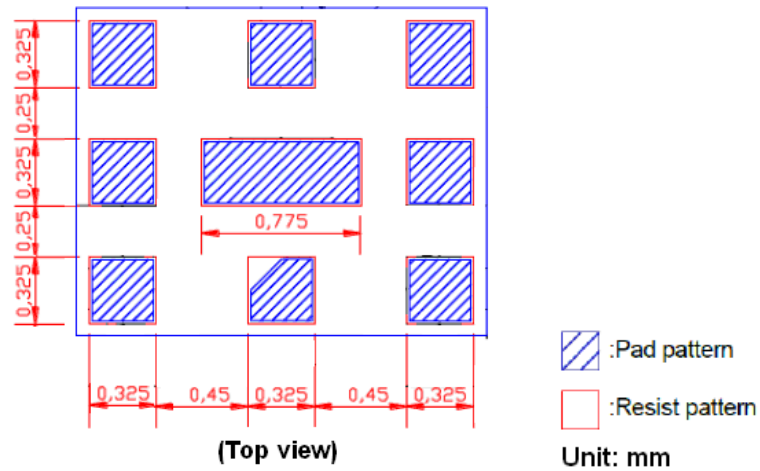

**F. OUTLINE DRAWING:**

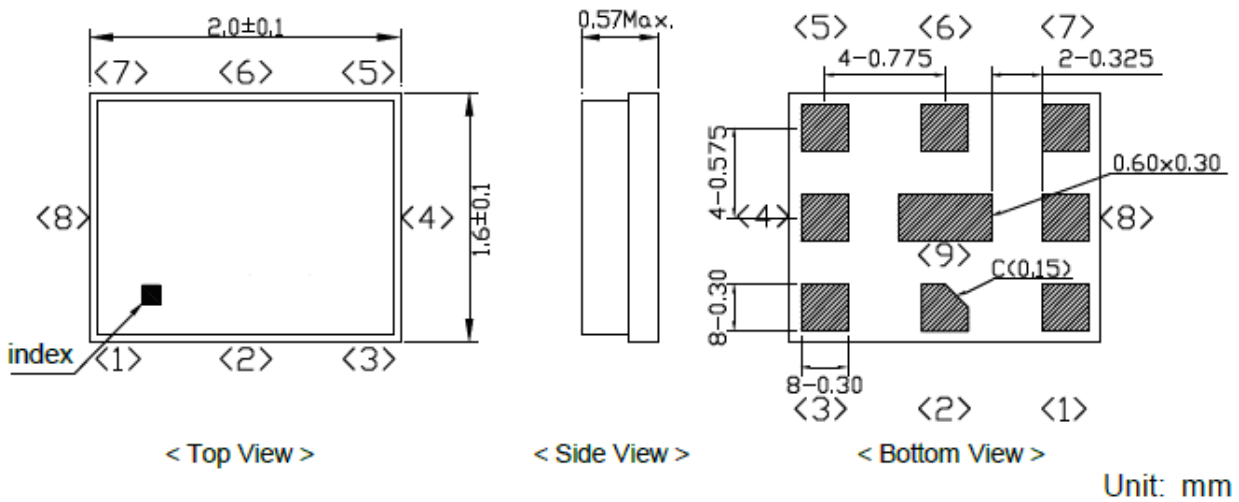

**Pin Configuration**

Pin No.	Pin name	Description
1	Rx	Receiver Pin
2	GND	Ground Pin
3	Tx	Transmitter Pin
4	GND	Ground Pin
5	GND	Ground Pin
6	ANT	Antenna Pin
7	GND	Ground Pin
8	GND	Ground Pin
9	GND	Ground Pin

**Top View (Sample Production):**

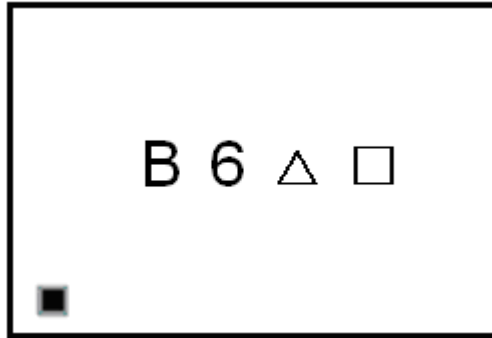

**Top View (Mass Production):**

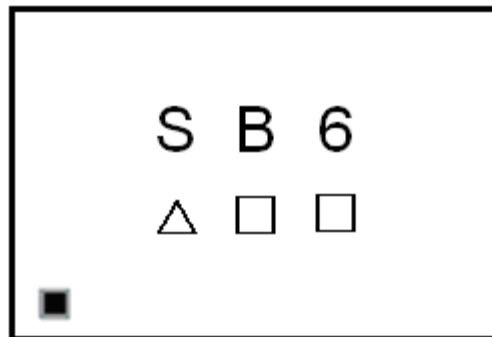

Δ: Date Code (Follow below table)

□: Lot No. (Indicated by 0~9 or A to Z and a to z, except I, O, i, o and l)

Date Code table:

Year	Jan.	Feb.	Mar.	Apr.	May	Jun.	Jul.	Aug.	Sep.	Oct.	Nov.	Dec.
2017	A	B	C	Ð	E	F	G	H	J	K	L	M
2018	N	P	Q	R	S	T	U	V	W	X	Y	Z
2019	a	b	c	d	e	f	g	h	J	k	l	m
2020	n	p	q	r	s	t	u	v	w	x	y	z

**G. PACKING:** (Ref: WI-75M03)

**1. REEL DIMENSION**

(Please refer to FR-75D10 for packing quantity)

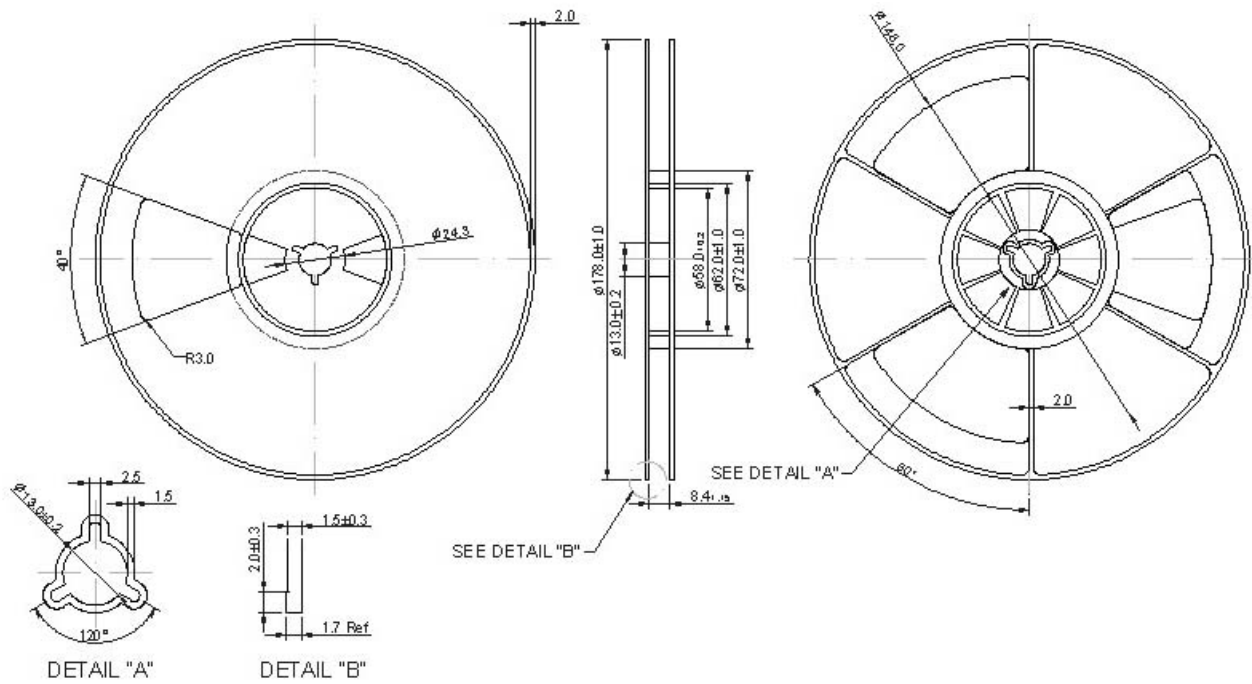

**2. TAPE DIMENSION**

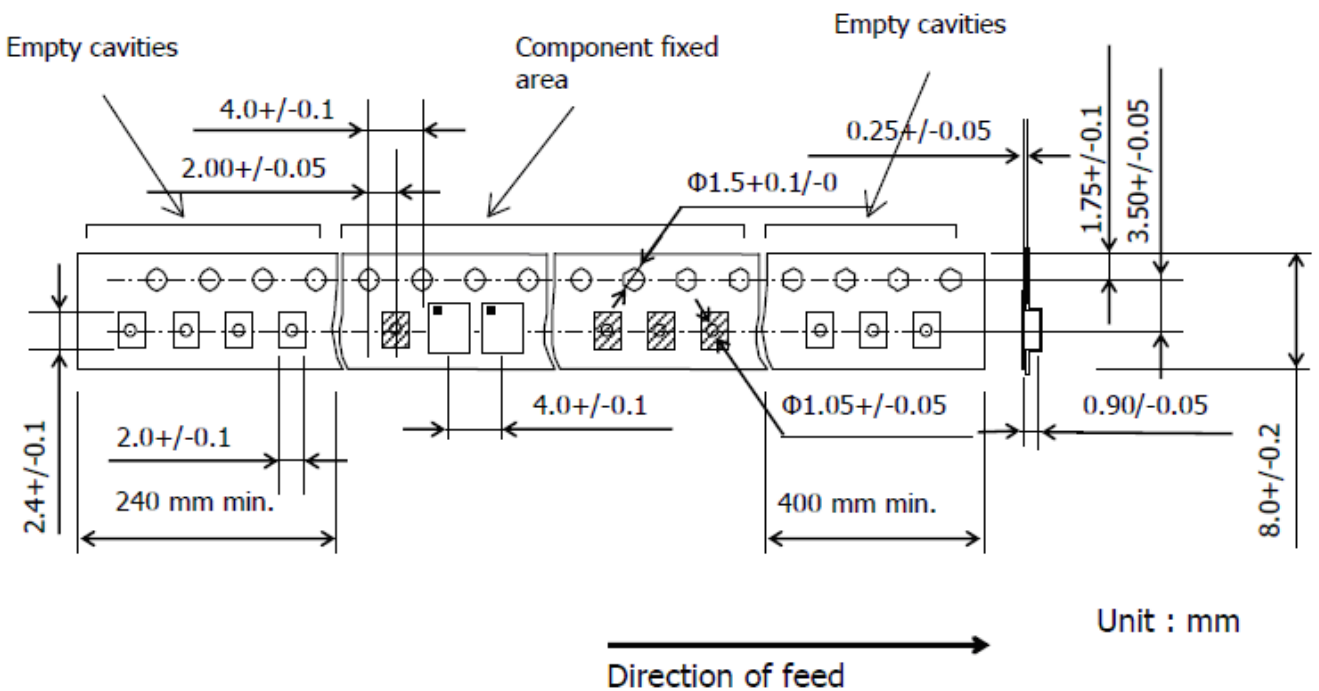

### H. Recommended Reflow Profile:

1. Preheating shall be fixed at 150~180°C for 60~90 seconds.
2. Ascending time to preheating temperature 150°C shall be 30 seconds min.
3. Heating shall be fixed at 220°C for 50~80 seconds and at 260°C +0/-5°C peak (20~40sec).
4. Time: 2 times.

