



# TAI-SAW TECHNOLOGY CO., LTD.

No. 3, Industrial 2nd Rd., Ping-Chen Industrial District,  
Taoyuan, 324, Taiwan, R.O.C.

TEL: 886-3-4690038 FAX: 886-3-4697532

E-mail: [tstsales@mail.taisaw.com](mailto:tstsales@mail.taisaw.com) Web: [www.taisaw.com](http://www.taisaw.com)

## Product Specifications Approval Sheet

Product Name: SAW DPX 1732.5/2132.5 MHz Band 4 SMD 2.0x1.6 mm (BW=45 MHz)

TST Parts No.: TF0110A

Customer Part No.: \_\_\_\_\_

Customer signature required
Company: _____
Division: _____
Approved by : _____
Date: _____

Checked by: \_\_\_\_\_ Hayley Chou *Hayley Chou*

Approved by: \_\_\_\_\_ Andy Yu *Andy Yu*

Date: \_\_\_\_\_ 2019/09/18

1. Customer signed back is required before TST can proceed with sample build and receive orders.
2. Orders received without customer signed back will be regarded as agreement on the specifications.
3. Any specifications changes must be approved upon by both parties and a new revision of specifications shall be released to reflect the changes



# TAI-SAW TECHNOLOGY CO., LTD.

No. 3, Industrial 2nd Rd., Ping-Chen Industrial District,  
Taoyuan, 324, Taiwan, R.O.C.

TEL: 886-3-4690038 FAX: 886-3-4697532

E-mail: [tstsales@mail.taisaw.com](mailto:tstsales@mail.taisaw.com) Web: [www.taisaw.com](http://www.taisaw.com)

## SAW DPX 1732.5/2132.5 MHz

MODEL NO.:TF0110A

REV. NO.:3.0

### A. MAXIMUM RATING:

1. Input Power Level (1710~1755 MHz): 29 dBm (50k hours Max.)
2. DC Voltage: +/-3 V
3. Operating Temperature: -20 °C to +85 °C
4. Storage Temperature: -40 °C to +100 °C
5. Moisture Sensitive Level: Level 1 (MSL1)
6. ESD: 50 V(MM), 100 V(HBM)

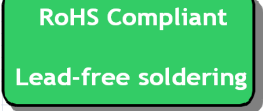

Electrostatic Sensitive Device (ESD)

### B. ELECTRICAL CHARACTERISTICS:

Terminating impedance (Tx port): 50 Ω

Terminating impedance (Rx port): 50 Ω

Terminating impedance (Ant port): 50//3.3nH Ω

#### Tx to Ant

Item	Unit	Min.	Typ.	Max.	Remark
<b>Insertion Loss</b> (1710~1755 MHz)	dB(*1)	-	1.5	2.0	-
<b>Signal Fidelity</b> (1710~1755 MHz)	dB	-	0.4	0.7	Over any 5 MHz in-band
<b>VSWR Ant</b> (1710~1755 MHz)	-	-	1.5	2.0	-
<b>VSWR Tx</b> (1710~1755 MHz)	-	-	1.6	2.0	-
<b>Attenuation</b> (Reference level from 0 dB)					
1559 ~ 1563 MHz	dB	42	46	-	Compass
1565.42 ~ 1573.374 MHz	dB	43	47	-	Wideband GPS, lower side-lobe
1573.374 ~ 1577.466 MHz	dB	43	48	-	Regular GPS, main-lobe
1577.466 ~ 1585.42 MHz	dB	43	47	-	Wideband GPS, upper side-lobe
1597.5515 ~ 1605.886 MHz	dB	40	44	-	GLONASS
2110 ~ 2155 MHz	dB	45	49	-	-
2400 ~ 2500 MHz	dB	35	40	-	-
3410 ~ 3520 MHz	dB	25	29	-	2fo
5130 ~ 5265 MHz	dB	15	19	-	3fo

## Ant to Rx

Item	Unit	Min.	Typ.	Max.	Remark
<b>Insertion Loss</b> (2110~2155 MHz)	dB(*1)	-	1.8	2.5	-
<b>Amplitude ripple</b> (2110~2155 MHz)	-	-	0.4	0.7	Over any 5 MHz in-band
<b>VSWR Ant</b> (2110~2155 MHz)	-	-	1.8	2.2	-
<b>VSWR Rx</b> (2110~2155 MHz)	-	-	1.5	2.0	-
<b>Attenuation</b> (Reference level from 0 dB)					
1 ~ 1710 MHz	dB	40	50	-	-
1710 ~ 1755 MHz	dB	45	50	-	-
2400 ~ 2500 MHz	dB	40	42	-	-
4220 ~ 4310 MHz	dB	37	44	-	2fo
6330 ~ 6465 MHz	dB	33	38	-	3fo

## Tx to Rx

Item		Unit	Min.	Typ.	Max.
<b>Isolation</b> (Reference level from 0 dB)	1710~1755 MHz	dB	54	58	-
	2110~2155 MHz	dB	48	51	-

(\*1) Specification of insertion loss excludes loss that comes from the test board.

### C. FREQUENCY CHARACTERISTICS:

**Tx to Ant**

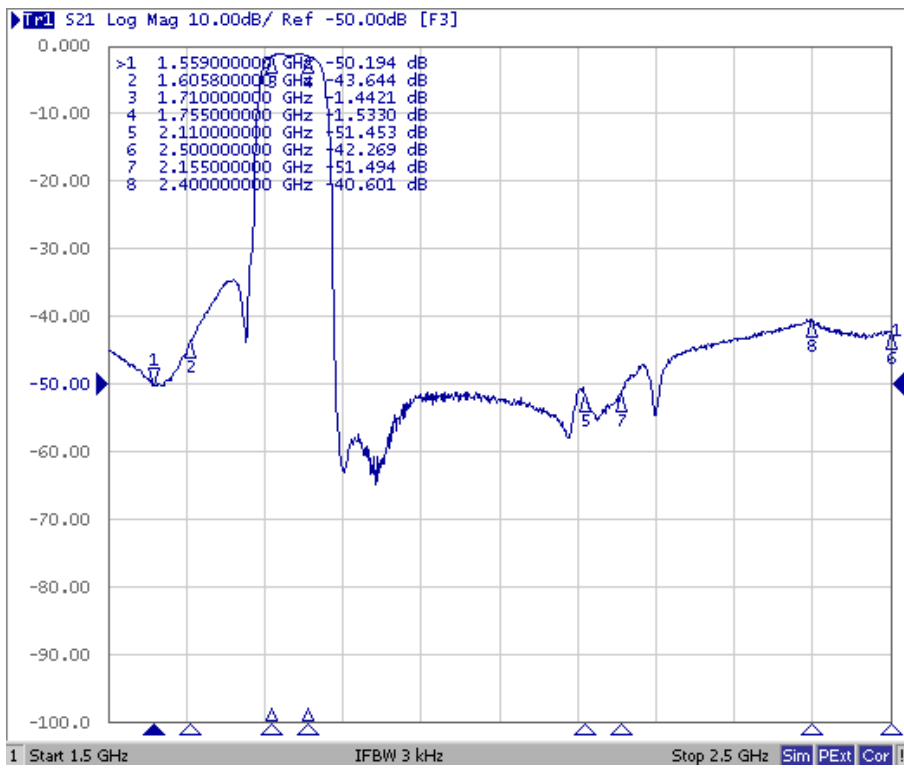

**Ant to Rx**

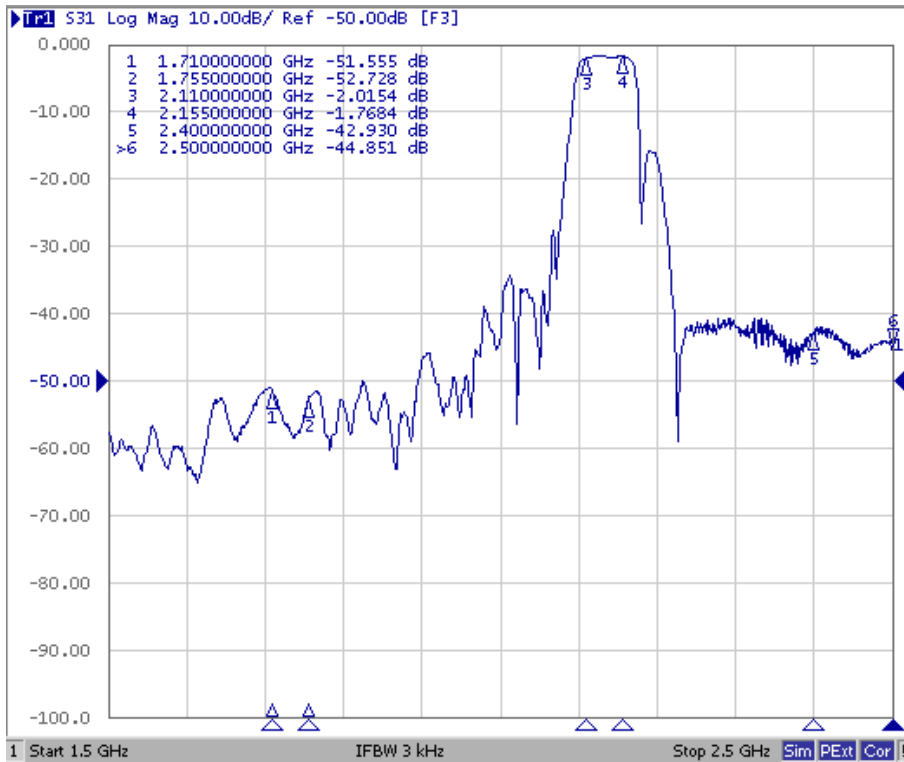

### Tx to Ant, Ant to Rx

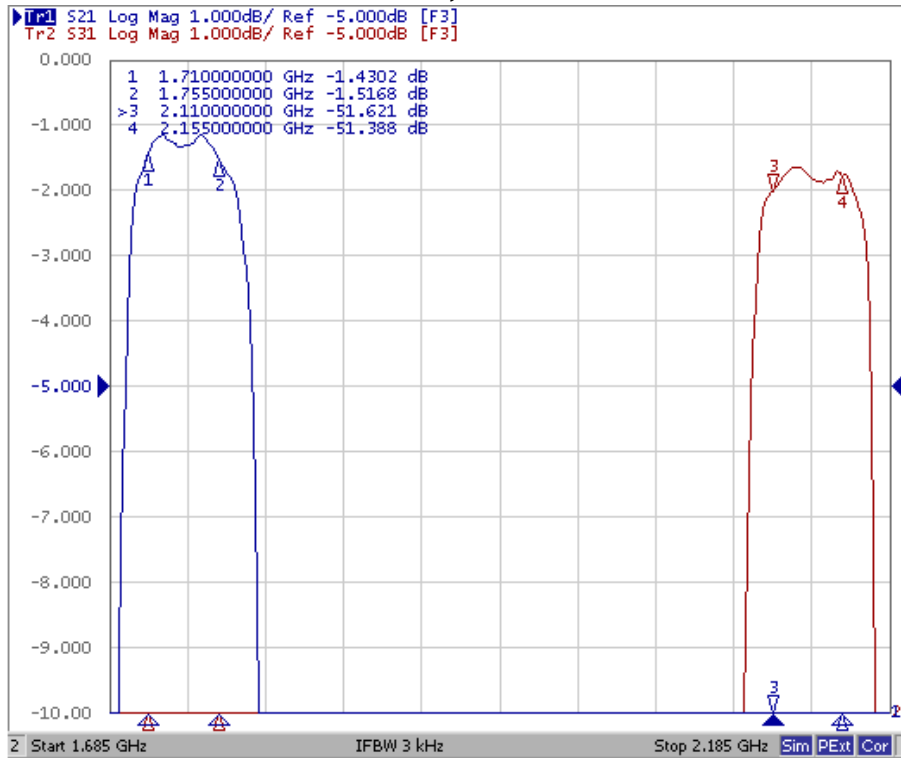

### Tx to Rx Isolation

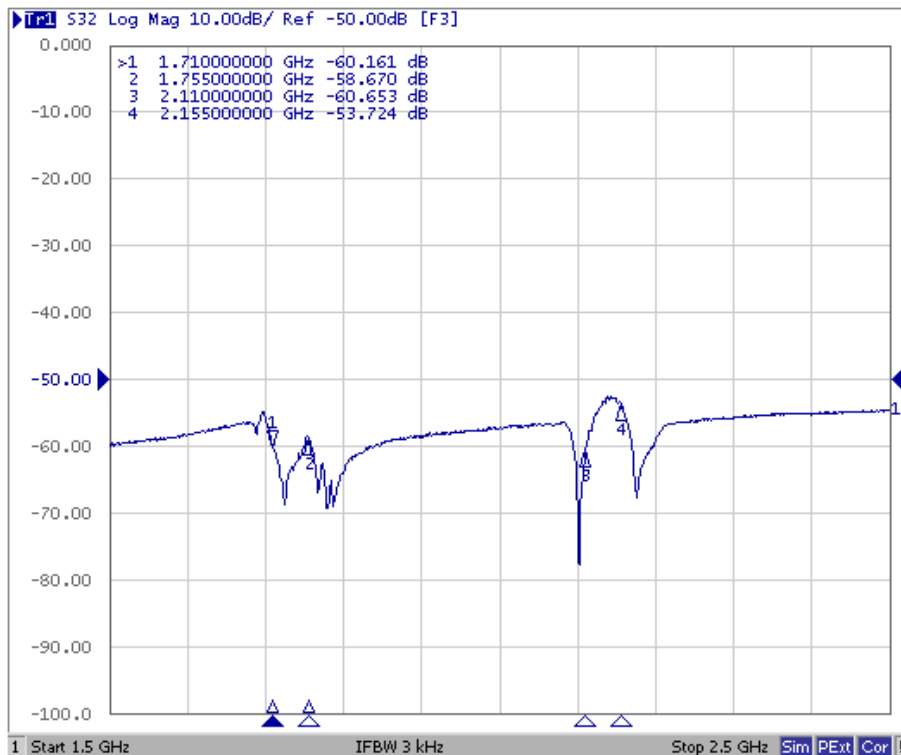

## Tx Port

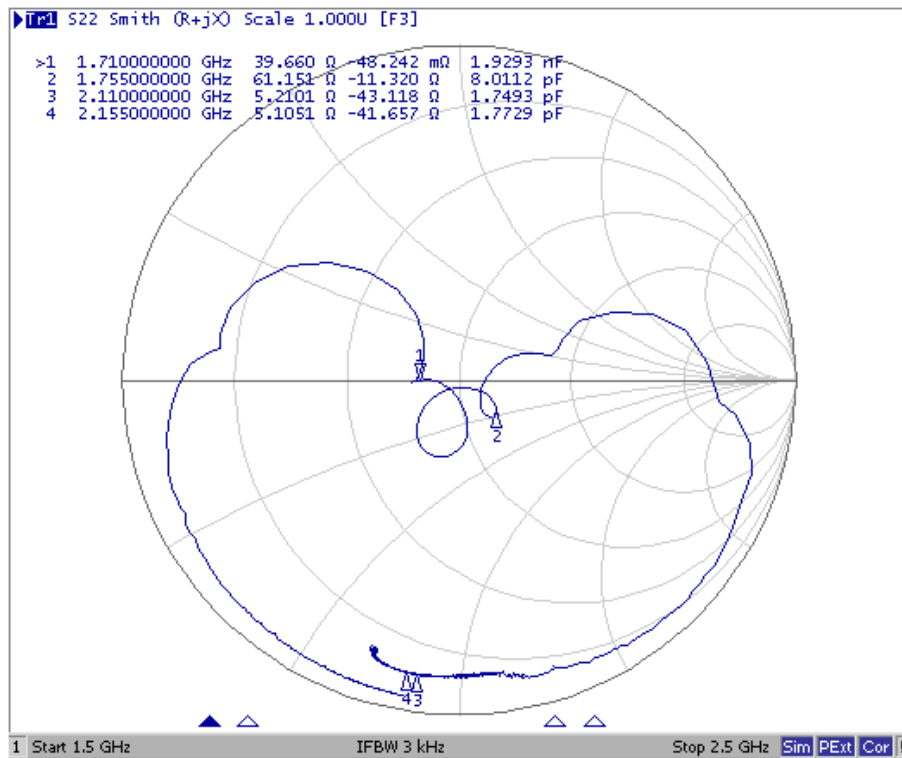
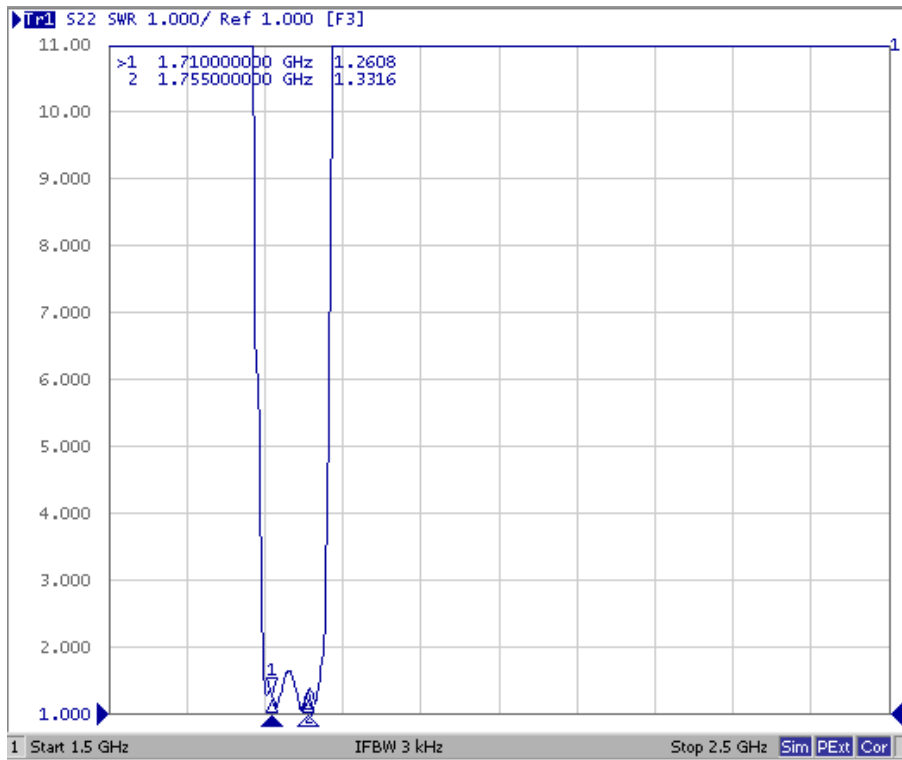

## Rx Port

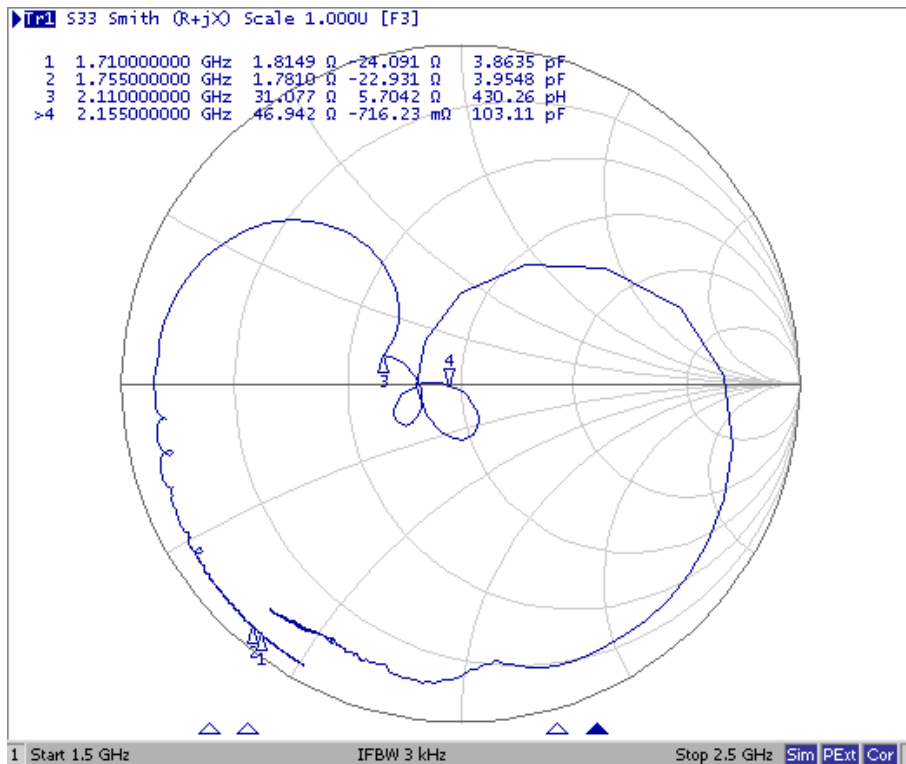
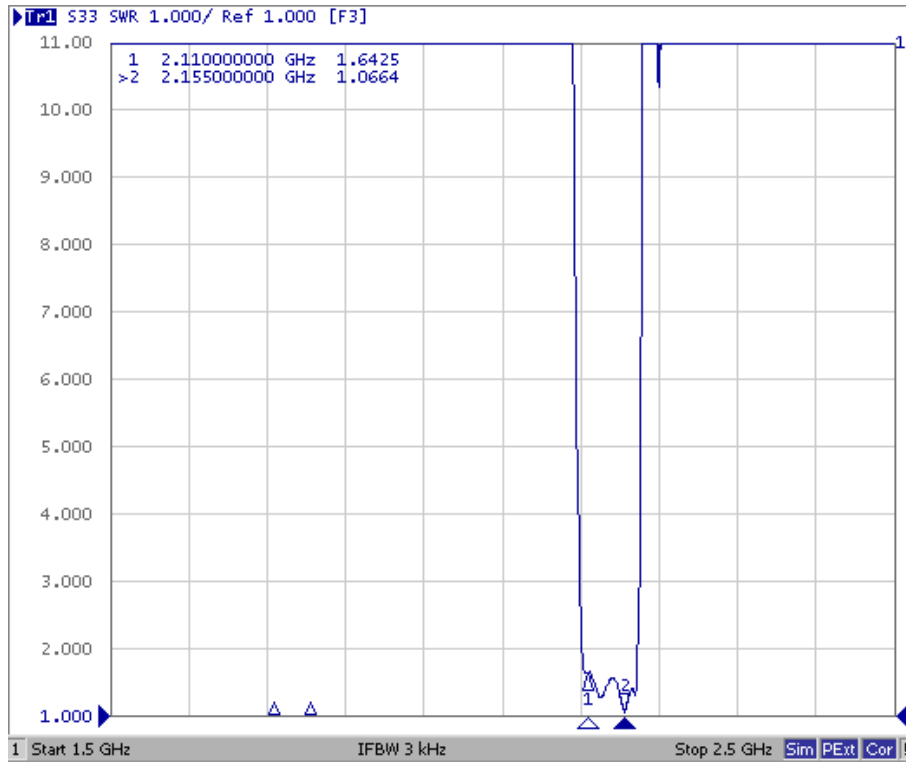

## Ant Port

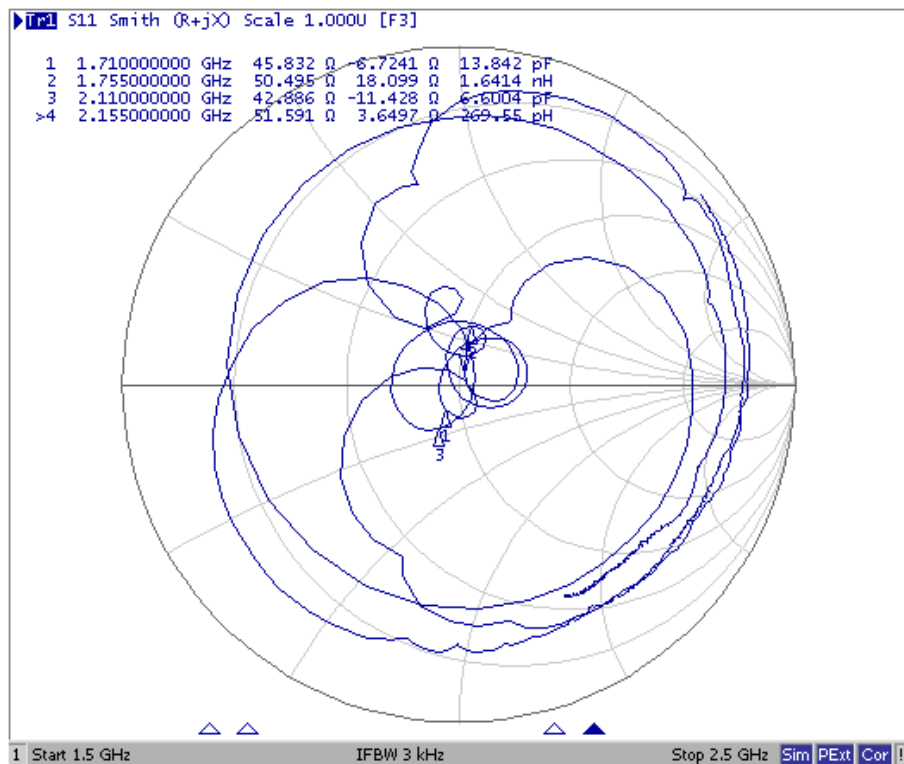
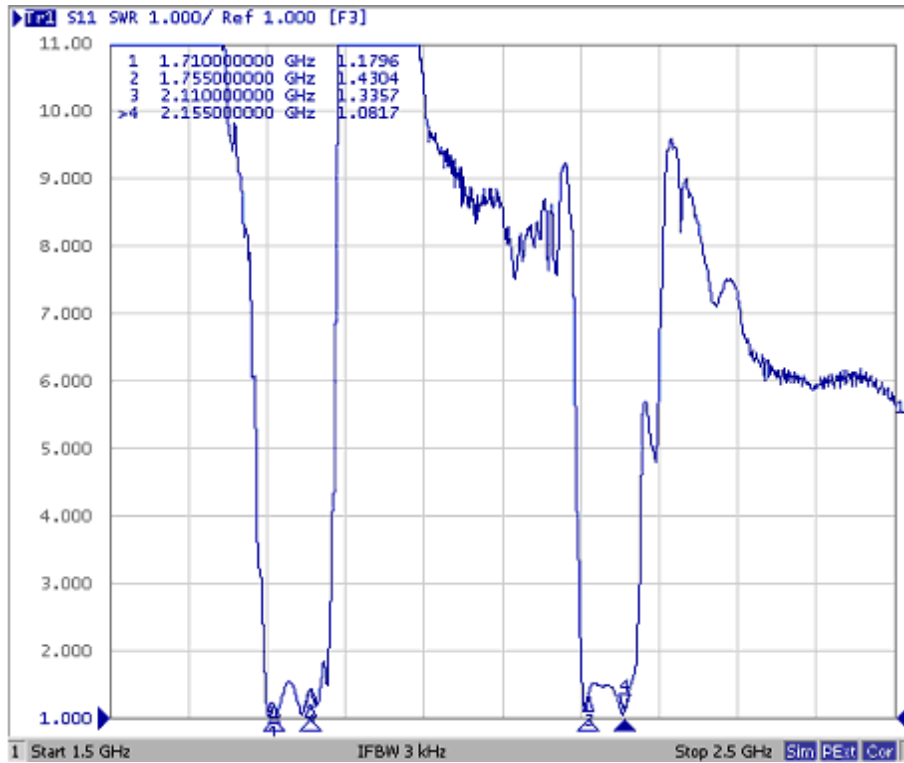



### Tx to Ant (Wide span)

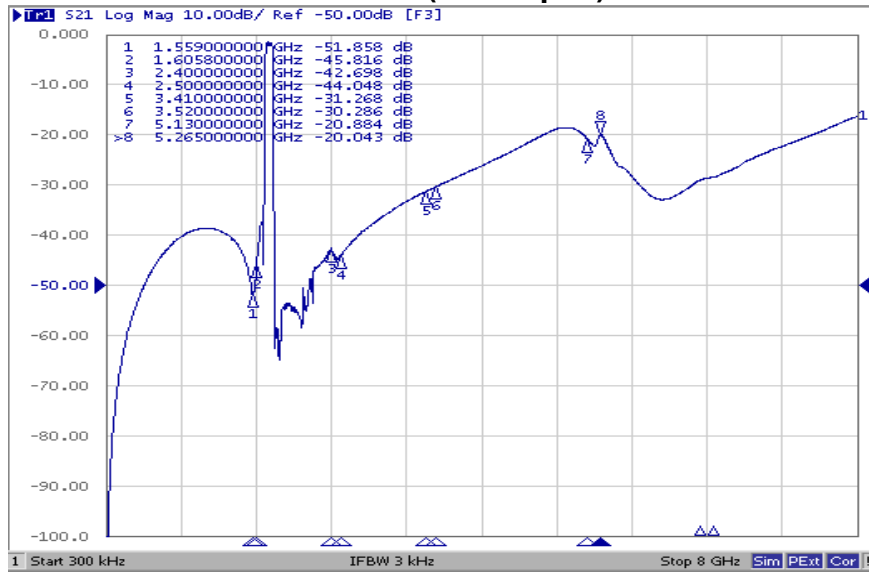

### Ant to Rx (Wide span)

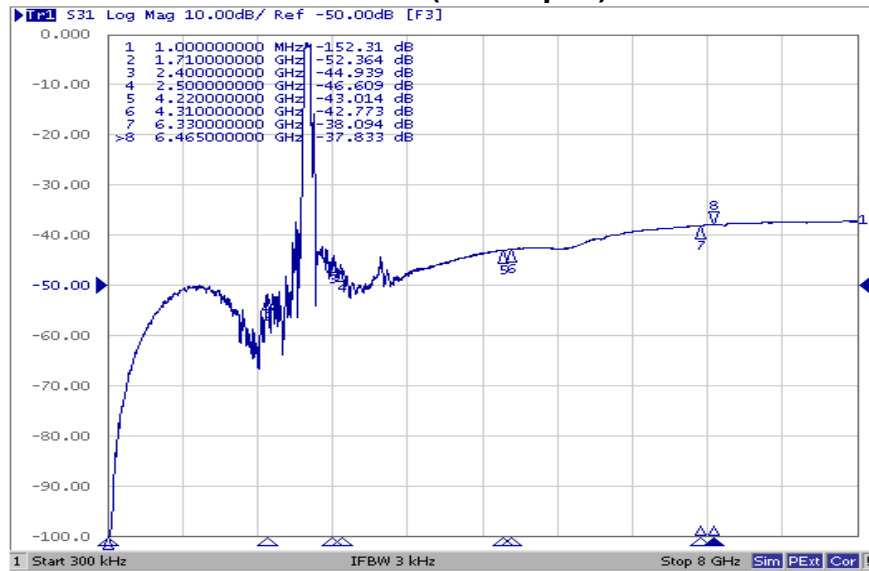

### Tx to Rx (Wide span)

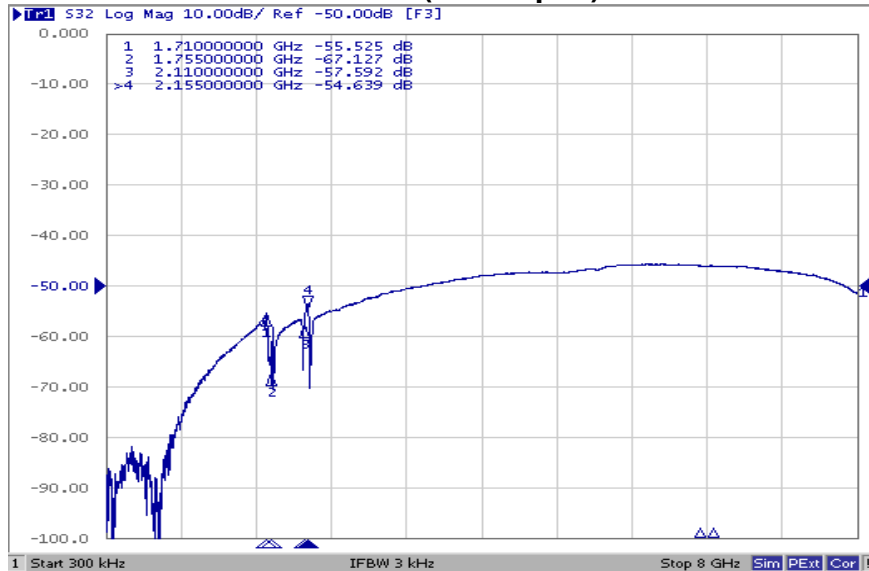

**D. MEASUREMENT CIRCUIT:**

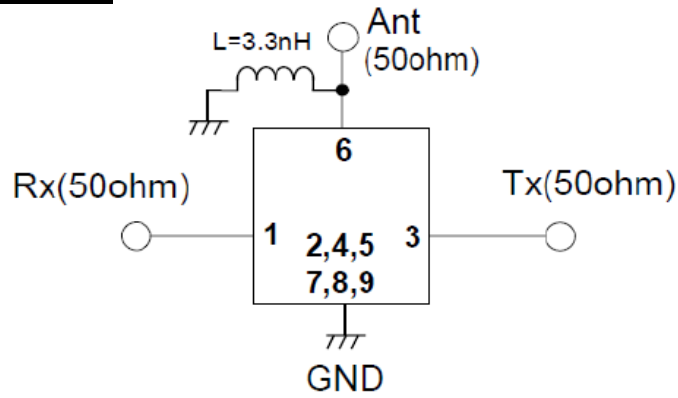

**E. PCB Footprint:**

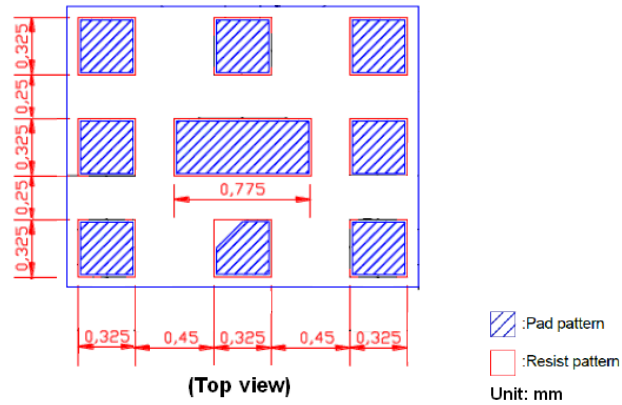

**F. OUTLINE DRAWING:**

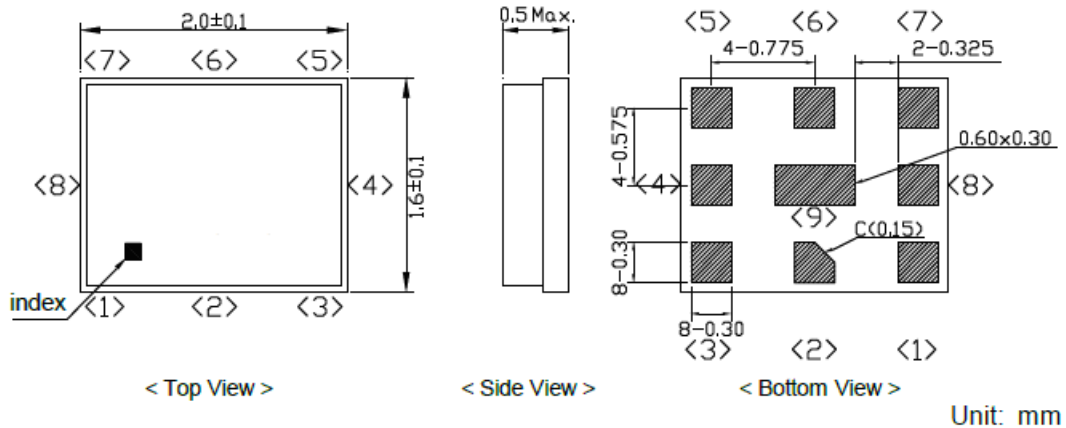

**Pin Configuration**

Pin No.	Symbol	Function
1	RX	Receiver
2	GND	Ground
3	TX	Transmitter
4	GND	Ground
5	GND	Ground
6	ANT	Antenna
7	GND	Ground
8	GND	Ground
9	GND	Ground

**Top View (Sample Production):**

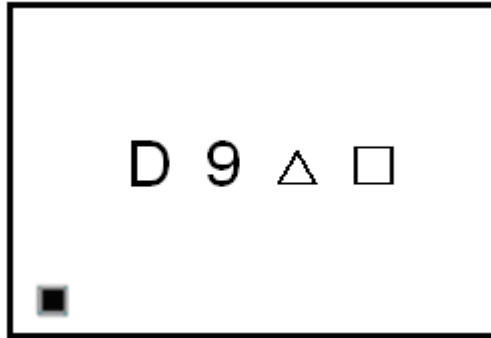

**Top View (Mass Production):**

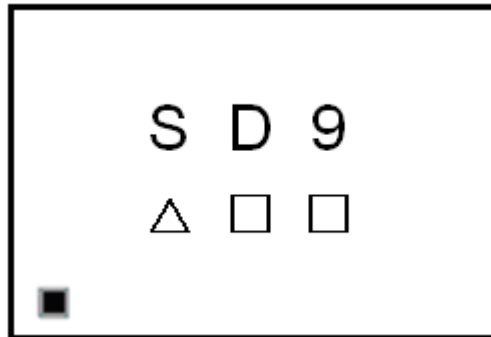

Δ: Date Code (Follow below table)

□: Lot No. (Indicated by 0~9 or A to Z and a to z, except l, O, i, o and l)

Date Code table:

Year	Jan.	Feb.	Mar.	Apr.	May	Jun.	Jul.	Aug.	Sep.	Oct.	Nov.	Dec.
2017	A	B	C	D	E	F	G	H	J	K	L	M
2018	N	P	Q	R	S	T	U	V	W	X	Y	Z
2019	a	b	c	d	e	f	g	h	J	k	l	m
2020	n	p	q	r	s	t	u	v	w	x	y	z

**G. PACKING:** (Ref: WI-75M03)

**1. REEL DIMENSION**

(Please refer to FR-75D10 for packing quantity)

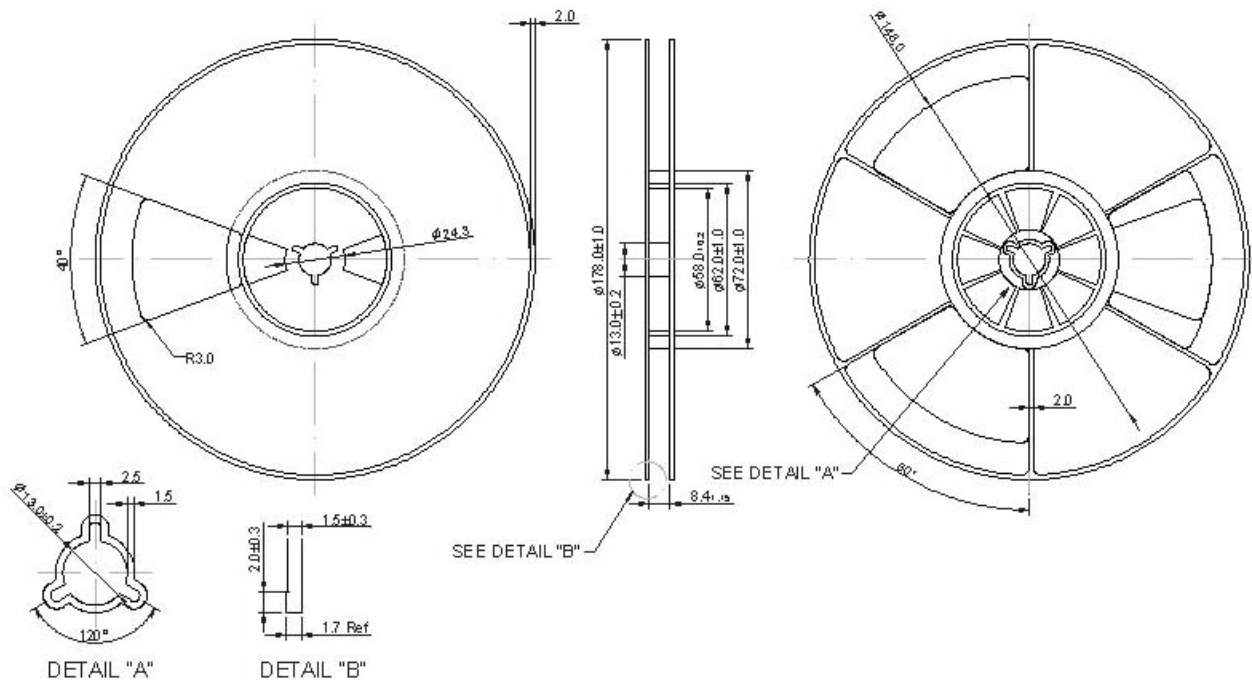

**2. TAPE DIMENSION**

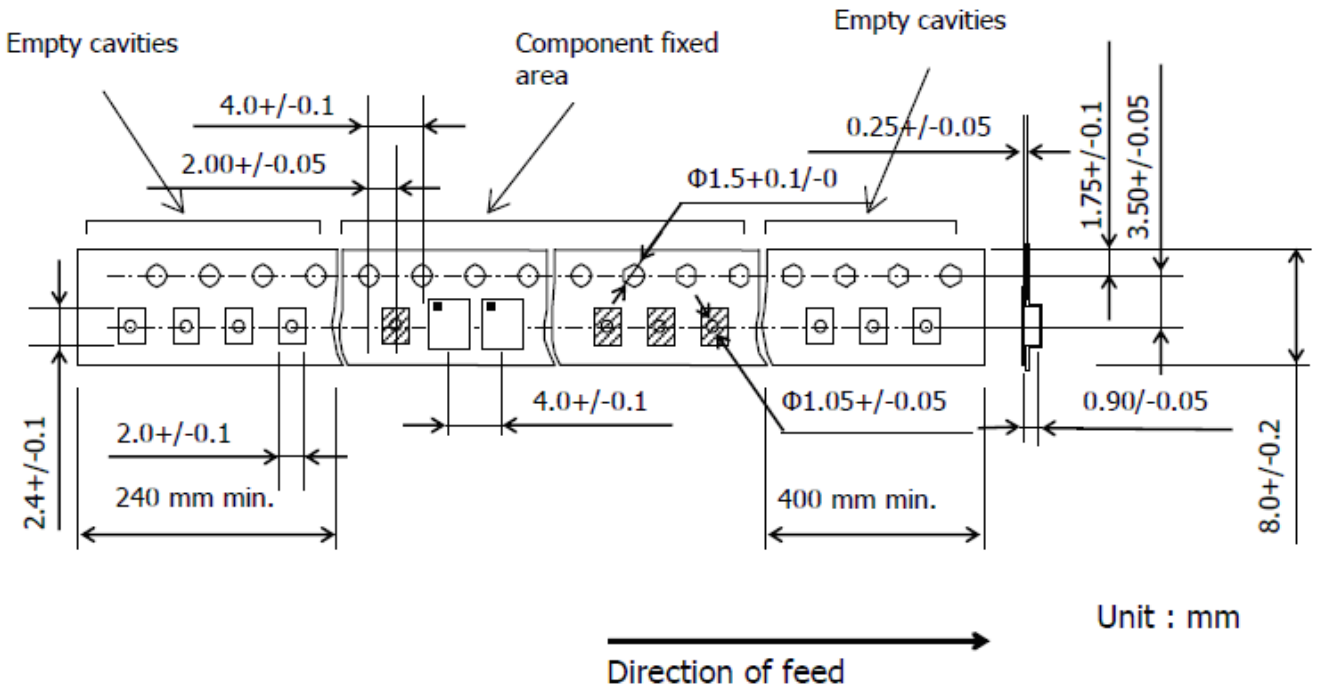

### H. Recommended Reflow Profile:

1. Preheating shall be fixed at 150~180°C for 60~90 seconds.
2. Ascending time to preheating temperature 150°C shall be 30 seconds min.
3. Heating shall be fixed at 220°C for 50~80 seconds and at 260°C +0/-5°C peak (20~40sec).
4. Time: 2 times.

