



# TAI-SAW TECHNOLOGY CO., LTD.

No. 3, Industrial 2nd Rd., Ping-Chen Industrial District,  
Taoyuan, 324, Taiwan, R.O.C.

TEL: 886-3-4690038 FAX: 886-3-4697532

E-mail: [tstsales@mail.taisaw.com](mailto:tstsales@mail.taisaw.com) Web: [www.taisaw.com](http://www.taisaw.com)

## Product Specifications Approval Sheet

Product Description: SAW DPX 1950/2140 MHz LTE Band 1 SMD 1814

TST Part No.: TF0120C (This part is compliant with AEC-Q200)

Customer Part No.: \_\_\_\_\_

Customer signature required
Company: _____
Division: _____
Approved by : _____
Date: _____

Checked by: \_\_\_\_\_ Anne Chen 

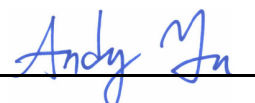
Approved by: \_\_\_\_\_ Andy Yu 

Date: \_\_\_\_\_ 2020 / 02 / 17

1. Customer signed back is required before TST can proceed with sample build and receive orders.
2. Orders received without customer signed back will be regarded as agreement on the specifications.
3. Any specifications changes must be approved upon by both parties and a new revision of specifications shall be released to reflect the change



# TAI-SAW TECHNOLOGY CO., LTD.

No. 3, Industrial 2nd Rd., Ping-Chen Industrial District,  
Taoyuan, 324, Taiwan, R.O.C.

TEL: 886-3-4690038 FAX: 886-3-4697532

E-mail: [tstsales@mail.taisaw.com](mailto:tstsales@mail.taisaw.com) Web: [www.taisaw.com](http://www.taisaw.com)

## SAW DPX 1950/2140 MHz LTE Band 1 SMD 1814 (59.04 MHz BW)

MODEL NO.:TF0120C

REV.No.:2.0

### A. MAXIMUM RATING:

1. Operating temperature range: -40 °C to +85 °C
2. Storage temperature range: -55 °C to +125 °C
3. Input power : 29dBm (Ta=+50deg C,10kh,CW )
4. Maximum DC Voltage: +/-3 V
5. Moisture Sensitivity Level: Level 3
6. ESD 50V(MM) 100V(HBM)

RoHS Compliant

Lead-free soldering

Electrostatic Sensitive Device (ESD)

### B. ELECTRICAL CHARACTERISTICS:

Terminating impedance (Tx Port): 50 Ω (Single-ended)

Terminating impedance (Rx Port): 50 Ω (Single-ended)

Terminating impedance (Ant Port): 50//2.7nH Ω (Single-ended)

#### Tx to ANT (f<sub>T0</sub>=1950 MHz)

Parameters Description		Unit	Min	Typ	Max	Remarks
Insertion Loss	1920.48~1979.52MHz	dB(*1)	-	1.8	2.2	
Amplitude ripple	1920.48~1979.52MHz	dB	-	0.6	1.2	
VSWR	Tx	-	-	1.8	2.2	
	ANT	-	-	1.5	2.0	
<b>Attenuation:</b>						
1559~1563 MHz		dB	38	41	-	
1565~1606 MHz		dB	38	41	-	
1805~1880 MHz		dB	10	25	-	
2110~2170 MHz		dB	42	50	-	
2400~2500 MHz		dB	33	37	-	
3840~3960 MHz		dB	25	29	-	

### ANT to Rx ( $f_{T0}=2140$ MHz)

Parameters Description		Unit	Min	Typ	Max	Remarks
Insertion Loss	2110.48~2169.52MHz	dB(*1)	-	1.8	2.2	
Amplitude ripple	2110.48~2169.52MHz	dB	-	0.6	1.2	
VSWR	ANT	2110.48~2169.52MHz	-	1.6	2.0	
	Rx		-	1.6	2.1	
<b>Attenuation:</b>						
190 MHz		dB	50	81	-	
1730~1790 MHz		dB	40	46	-	
1920~1980 MHz		dB	45	49	-	
1980~2015 MHz		dB	15	49	-	
2015~2075 MHz		dB	18	28	-	
2400~2500 MHz		dB	35	40		
4030~4150 MHz		dB	35	44		
5950~6130 MHz		dB	33	41		

### Tx to Rx

Isolation	1920.48~1979.52 MHz	dB	53	56	-	
			53	57	-	
	2110.48~2169.52 MHz	dB	49	51	-	
			51	55	-	

(\*1) Specification of insertion loss excludes loss that comes from the test board.

### C. FREQUENCY CHARACTERISTICS:

#### Tx to Ant

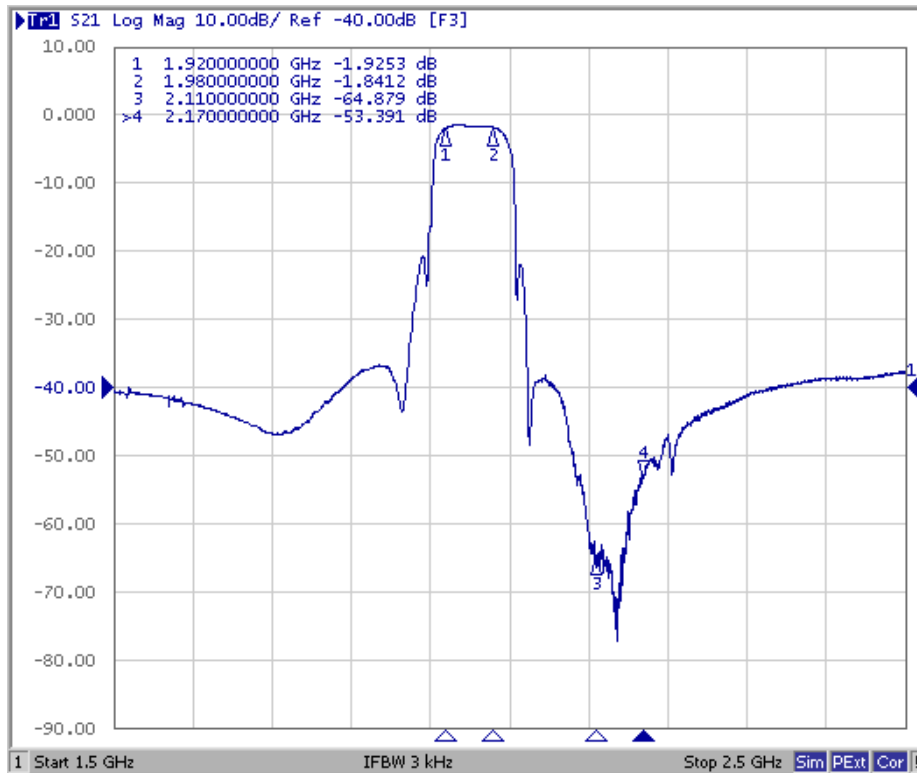

#### Ant to Rx

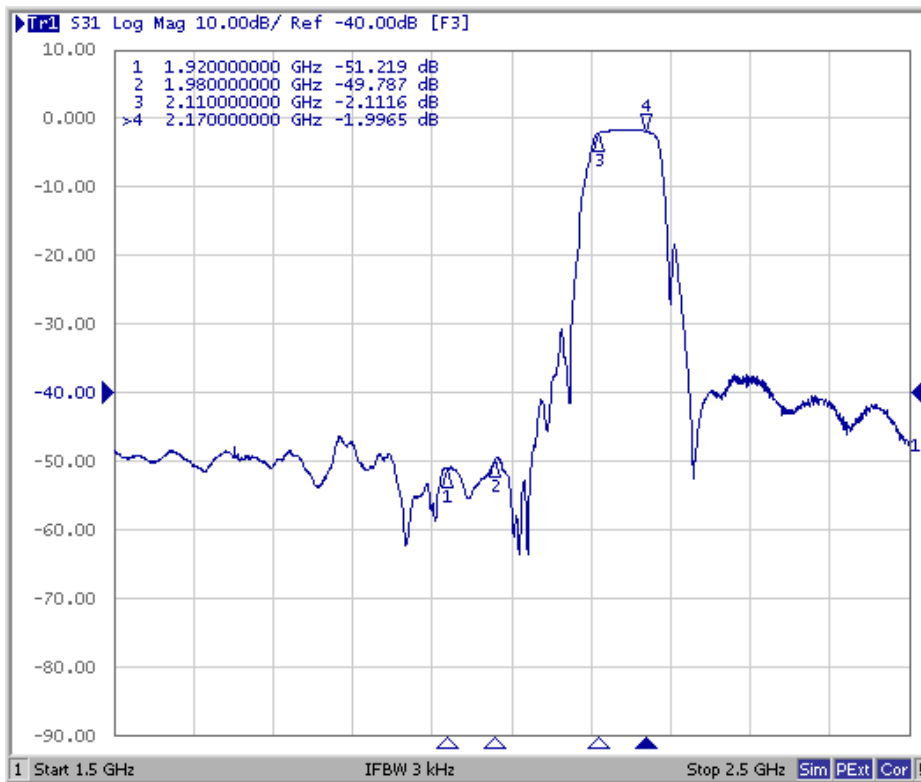

These data **exclude** loss that comes from the test board.

## Tx to Ant ,Ant to Rx

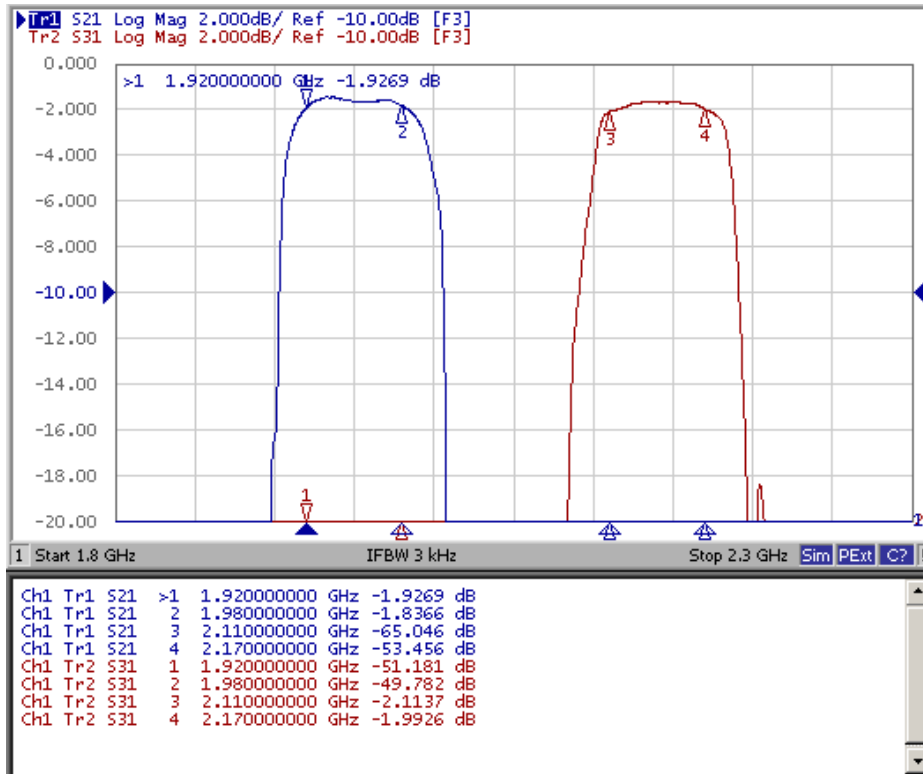

## Tx to Rx Isolation

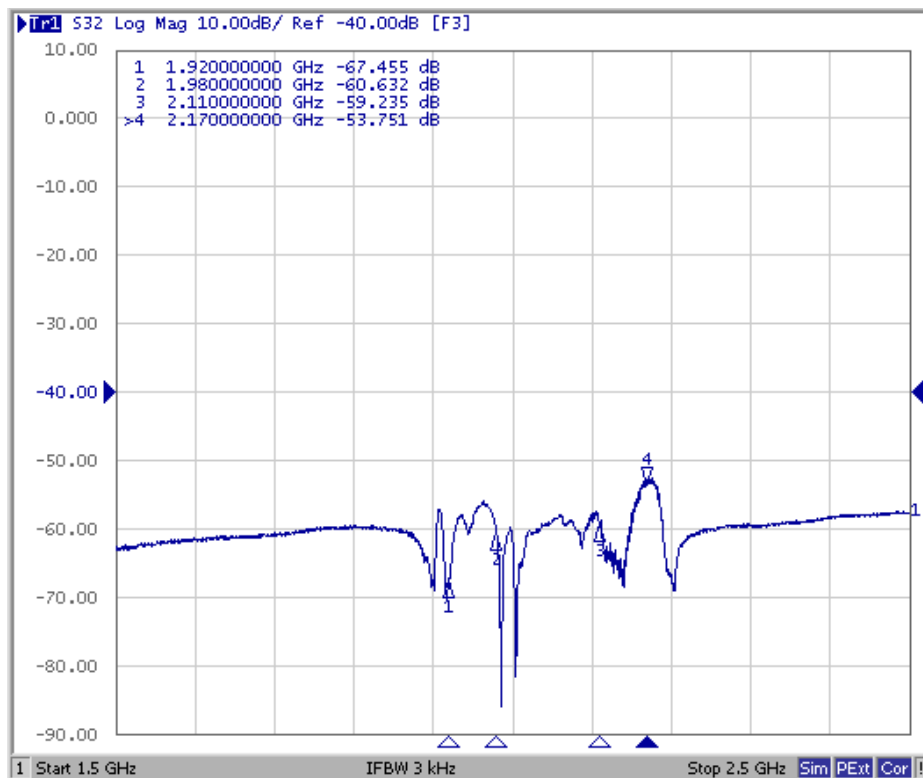

These data **exclude** loss that comes from the test board.

# Tx Port

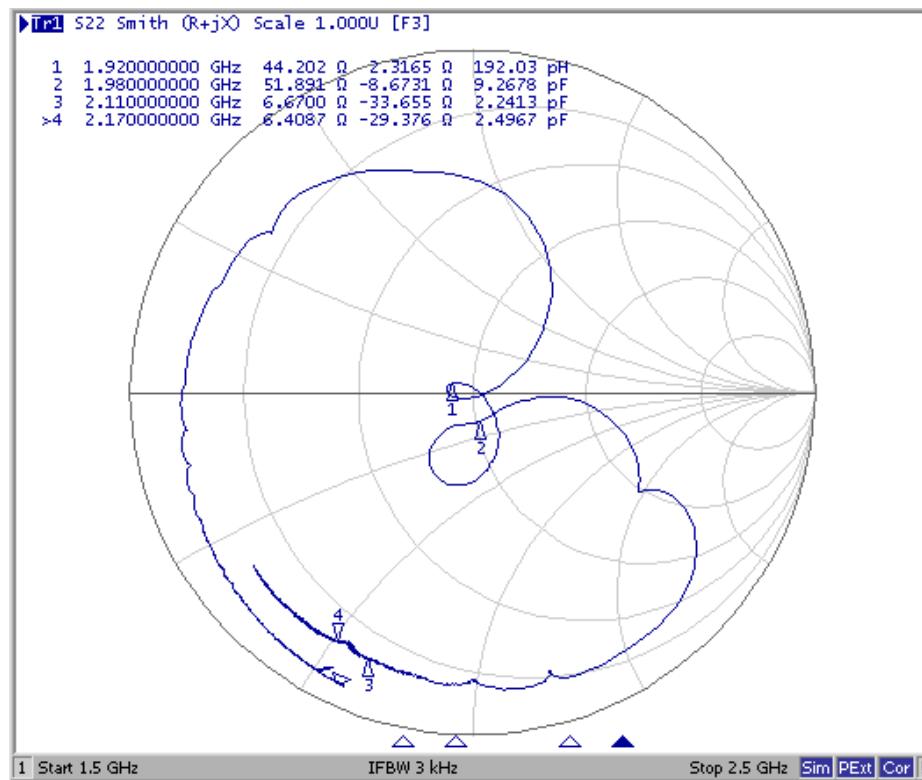
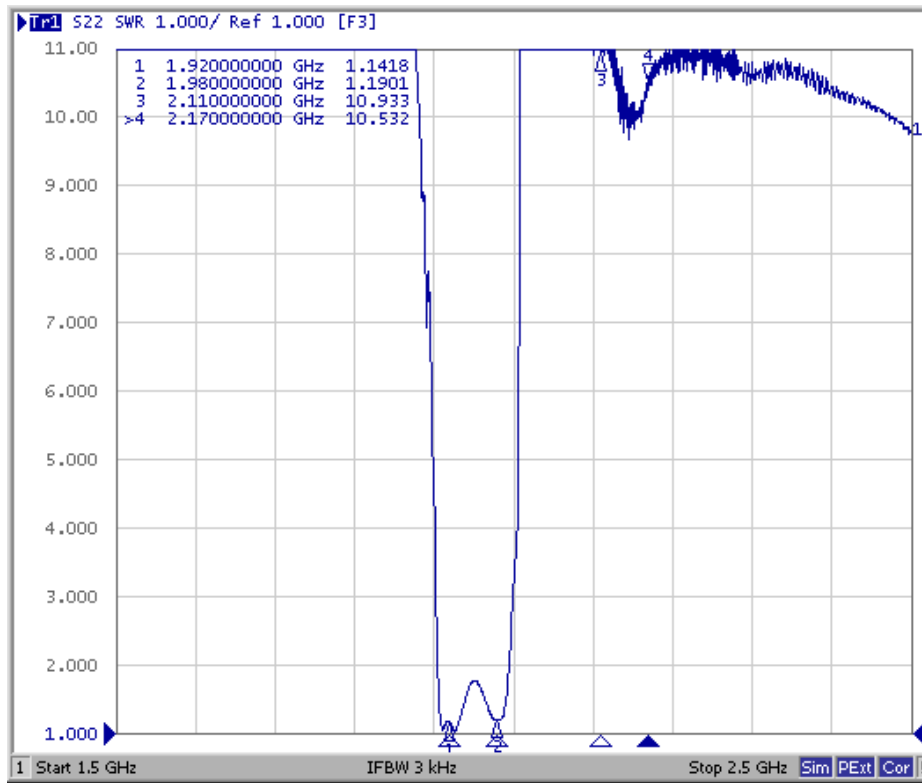

# Rx Port

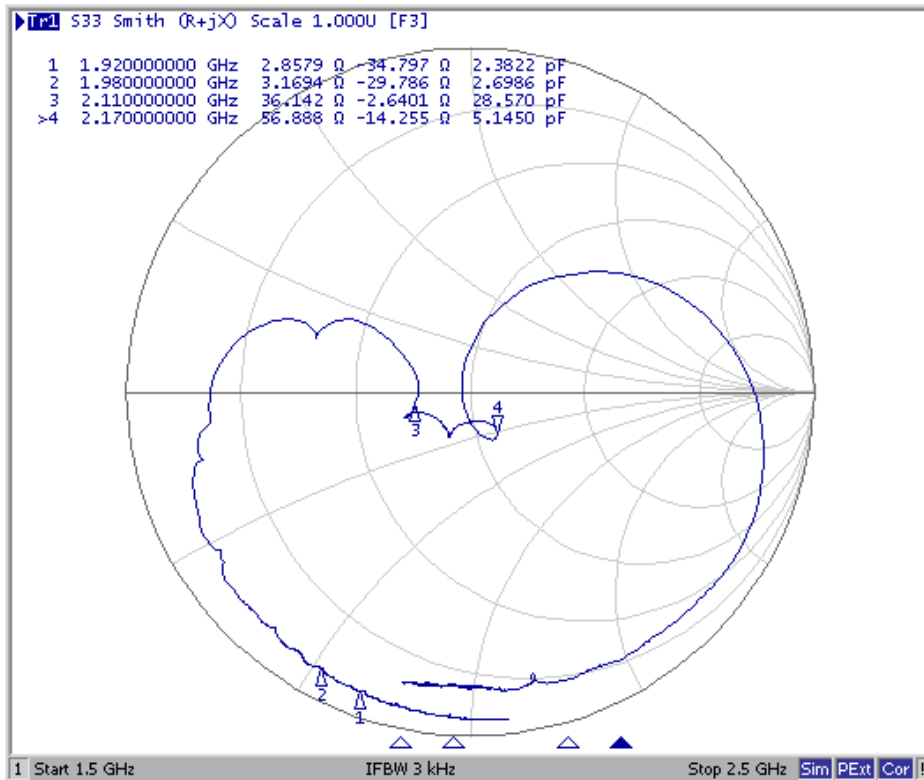
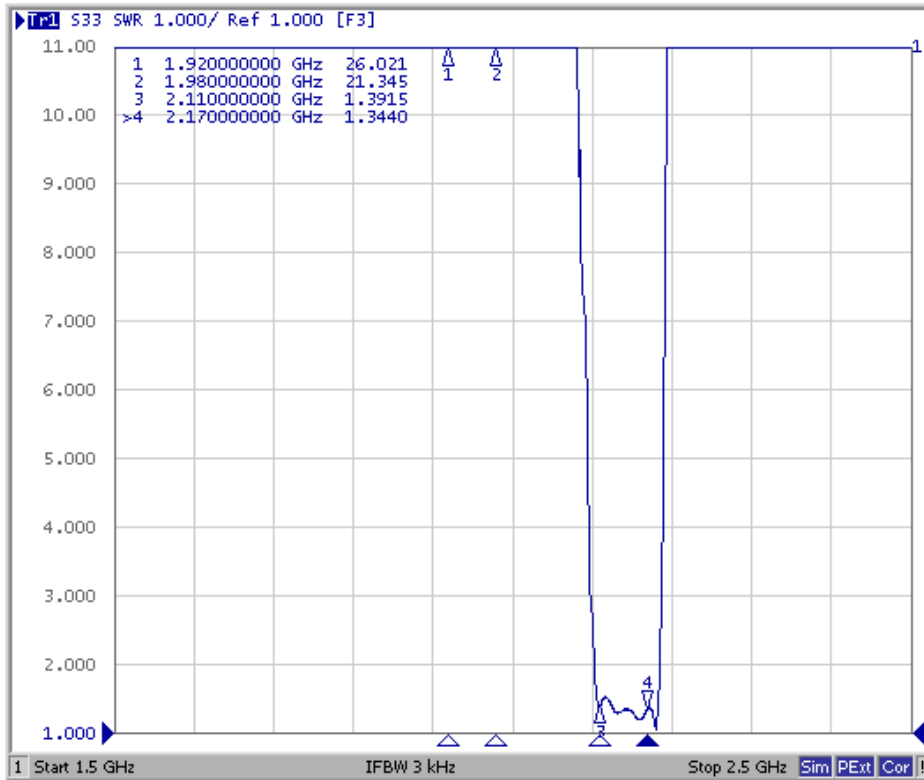

# Ant Port

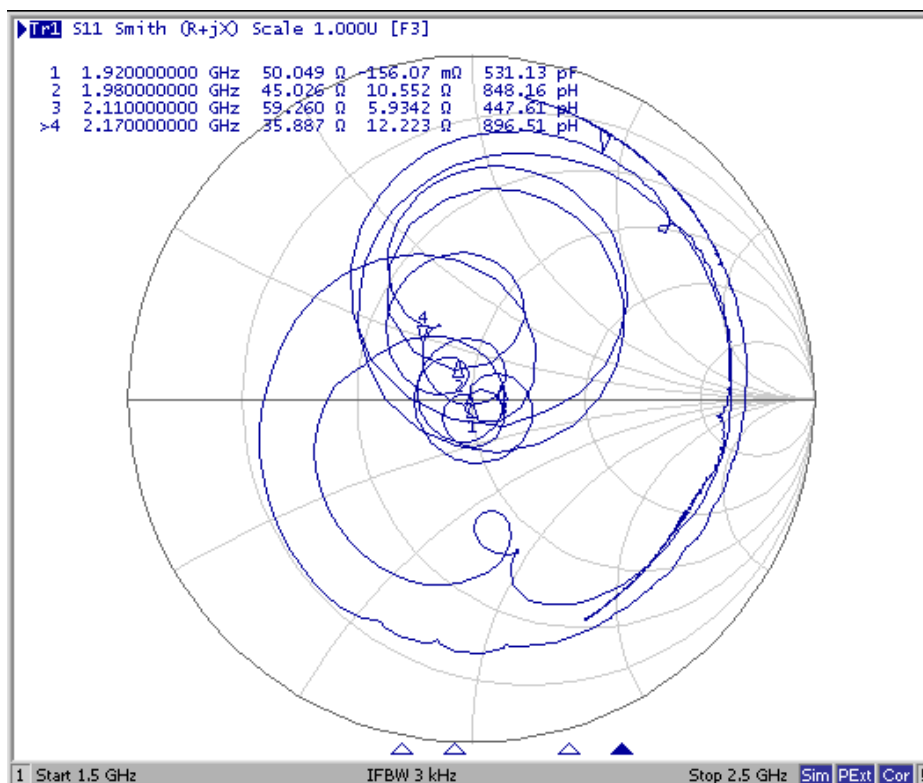
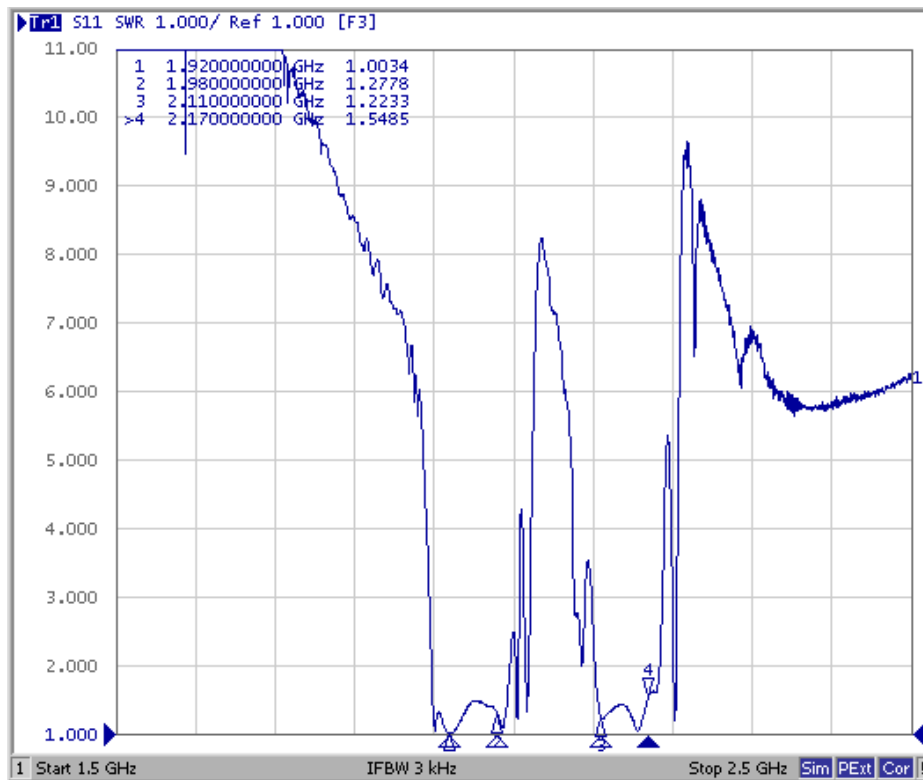



## Tx to Ant (Wide span)

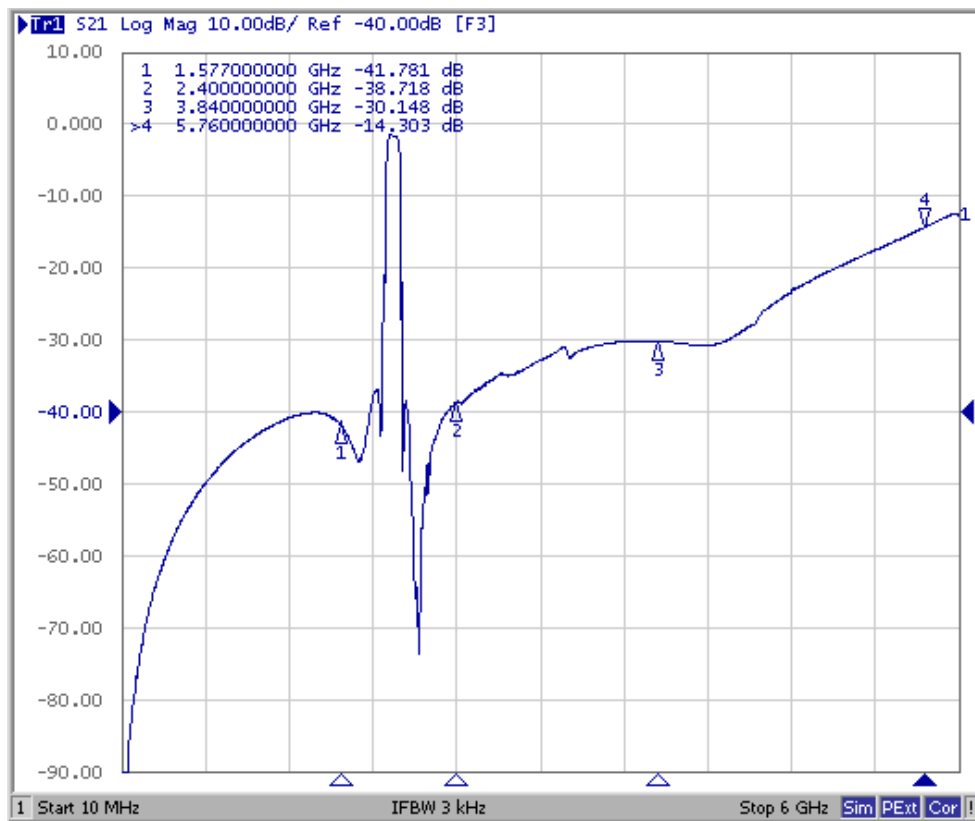

## Ant to Rx (Wide span)

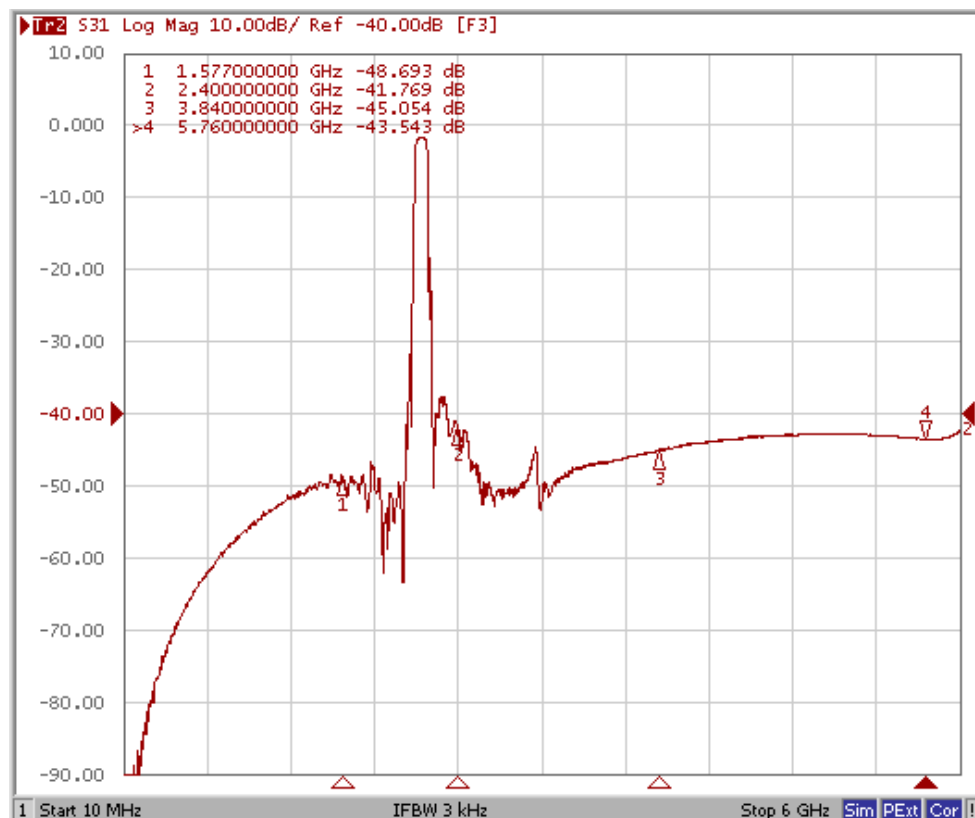

**D. OUTLINE DRAWIN:**

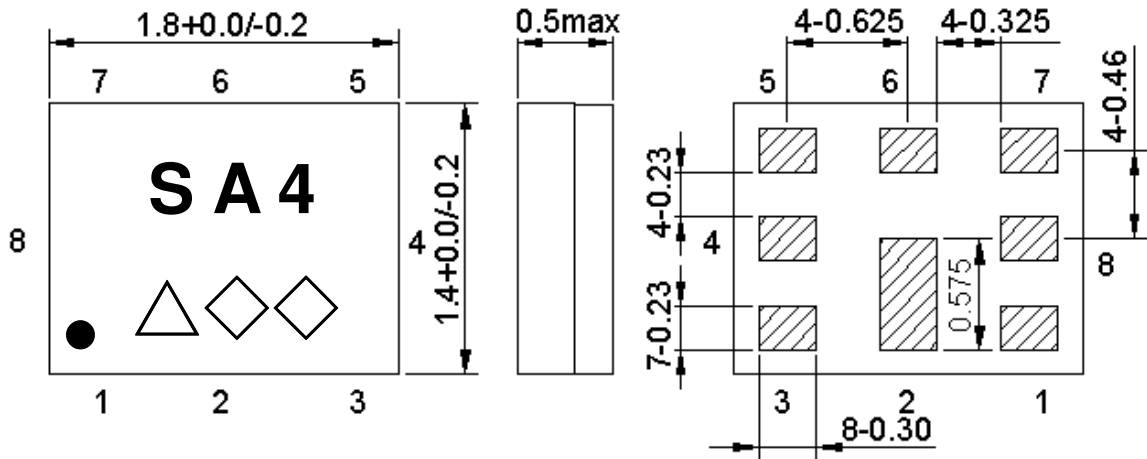

Not Specified Tolerance :  $\pm 0.05$  mm  
 Coplanarity :  $0.1$  mm max.  
 1 to 8 : Pin No.  
 Unit : mm

Marking name : **SA4**

△: Date code( 2016 May → s ,....., 2019 Dec→m.)

◇◇: Lot Code.

Product Date Code. Follow below table.

Year	Jan	Feb	Mar	Apr	May	Jun	Jul	Aug	Sep	Oct	Nov	Dec
2016	n	p	q	r	s	t	u	v	w	x	y	z
2017	A	B	C	D	E	F	G	H	J	K	L	M
2018	N	P	Q	R	S	T	U	V	W	X	Y	Z
2019	a	b	c	d	e	f	g	h	j	k	l	m
2020	n	p	q	r	s	t	u	v	w	x	y	z
2021	A	B	C	D	E	F	G	H	J	K	L	M

**Pin Configuration:**

Pin No.	Pin Name	Description
1	Rx	Receive Pin
2	GND	Ground Pin
3	Tx	Transmitter Pin
4	GND	Ground Pin
5	GND	Ground Pin
6	ANT	Antenna Pin
7	GND	Ground Pin
8	GND	Ground Pin

### E. Evaluation Circuit

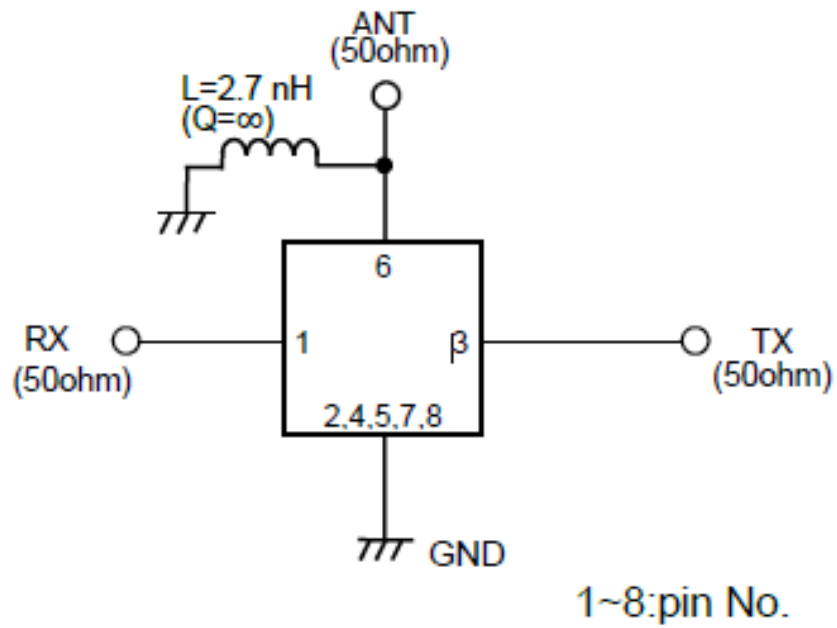

### F. FOOTPRINT:

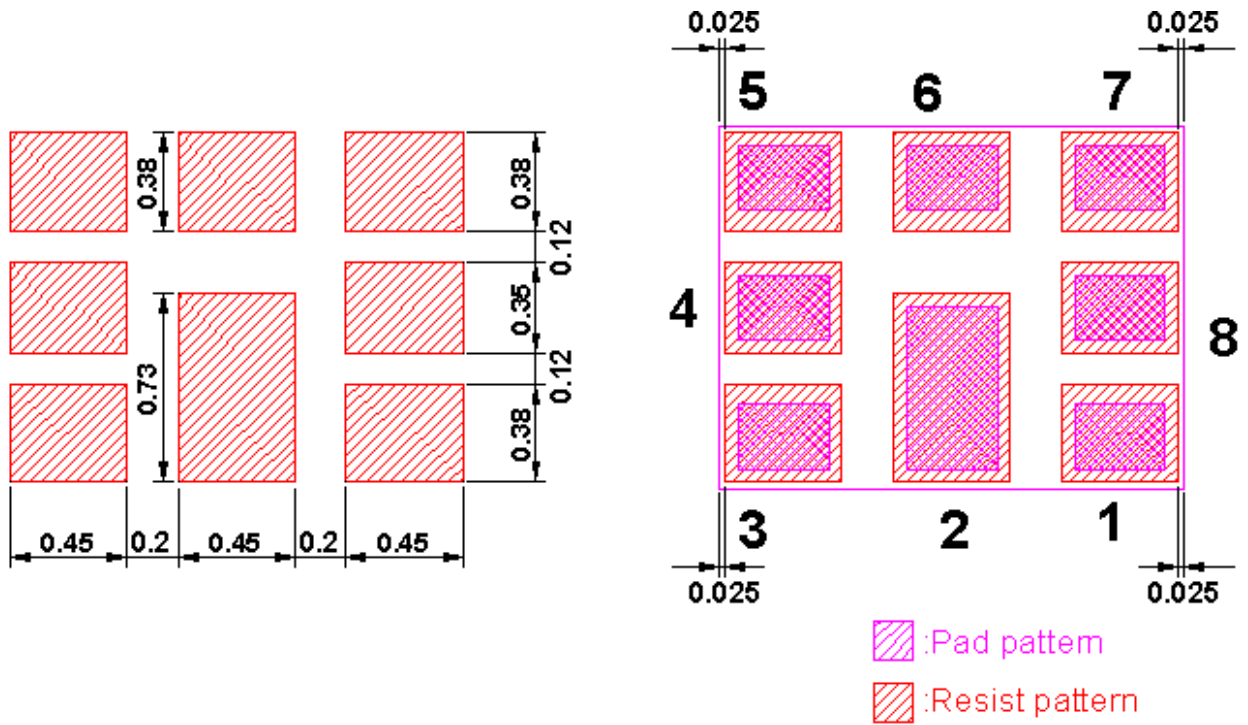

**G. PACKING:**

1. REEL DIMENSION

(Please refer to FR-75D10 for packing quantity)

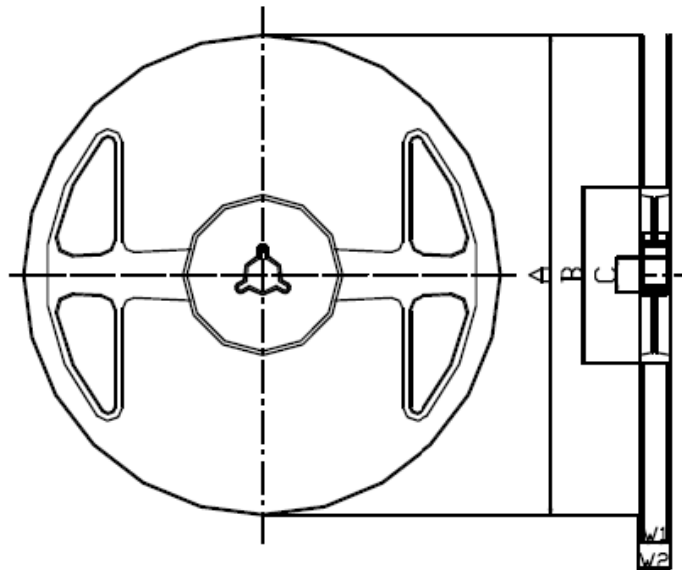

**Materials of Reel**

Material : Polystyrene + Carbon

Characteristics : Conforms to EIAJ-ET-7200A

Color : Black

Surface resistance (reference value) :  $10^9\Omega/\text{sq}$  Max.

Unit : mm

Code	Quantity	A	B	C	W1	W2
Z	3,000 pcs	$\phi 180.0 +0.0/-1.5$	$\phi 66.0 +/-0.5$	$\phi 13.0 +/-0.2$	$9.0 +1.0/-0.0$	$11.4 +/-1.0$

2. TAPE DIMENSION

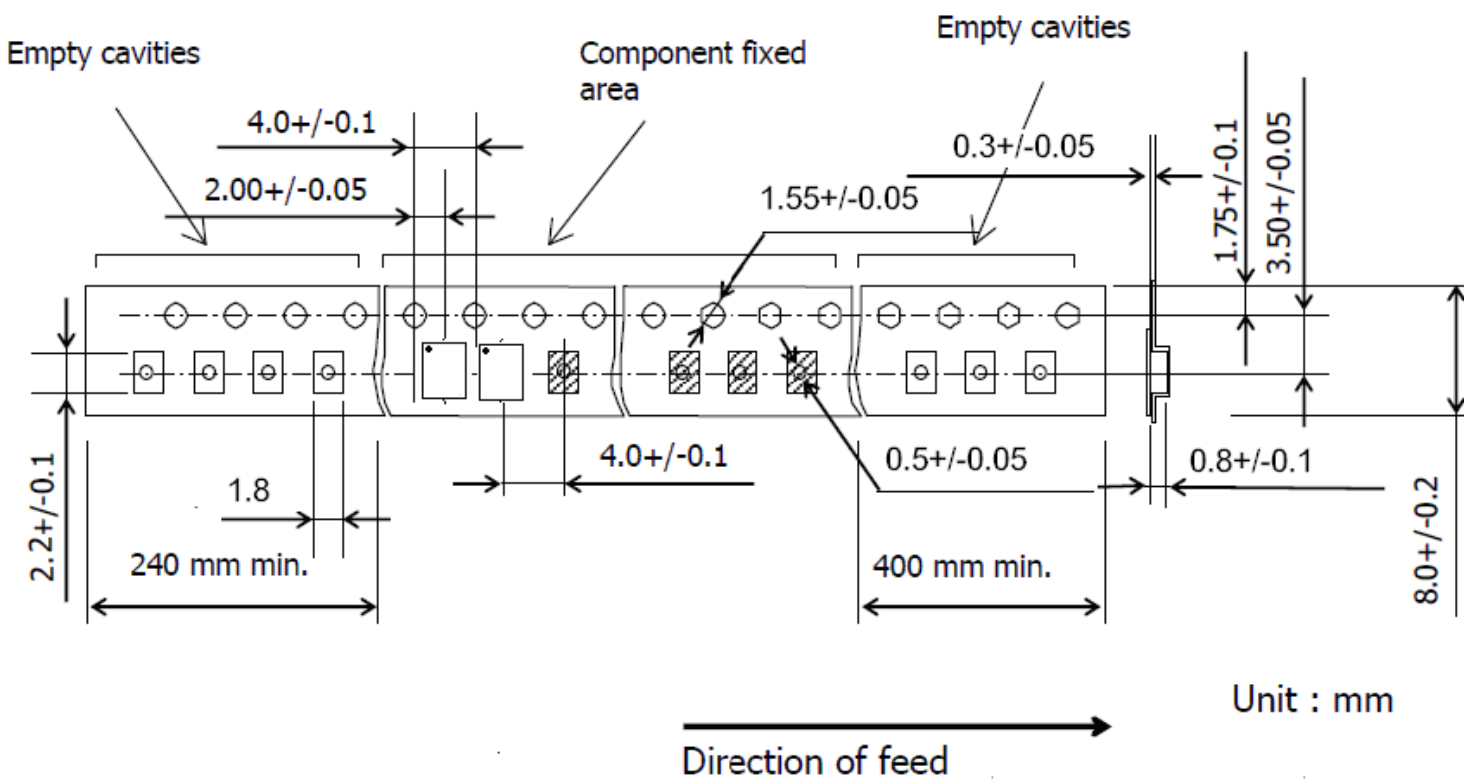

Unit : mm

## H. RECOMMENDED REFLOW PROFILE :

1. Preheating shall be fixed at 150~180°C for 60~90 seconds.
2. Ascending time to preheating temperature 150°C shall be 30 seconds min.
3. Heating shall be fixed at 220°C for 50~80 seconds and at 245~260°C peak (min. 10sec).
4. Time : 3 times.

