



TAI-SAW TECHNOLOGY CO., LTD.

No. 3, Industrial 2nd Rd., Ping-Chen Industrial District,
Taoyuan, 324, Taiwan, R.O.C.

TEL: 886-3-4690038 FAX: 886-3-4697532

E-mail: tstsales@mail.taisaw.com Web: www.taisaw.com

Product Specifications Approval Sheet

Product Description: SAW DPX 1880/1960 MHz Band 2 SMD 1.8X1.4 mm (BW=59.04 MHz)

TST Part No.: TF0121B(This part is compliant with AEC-Q200)

Customer Part No.: _____

Customer signature required
Company: _____
Division: _____
Approved by : _____
Date: _____

Checked by: _____ Anne Chen *Anne Chen*

Approved by: _____ Andy Yu *Andy Yu*

Date: _____ 2018 / 11 / 30

1. Customer signed back is required before TST can proceed with sample build and receive orders.
2. Orders received without customer signed back will be regarded as agreement on the specifications.
3. Any specifications changes must be approved upon by both parties and a new revision of specifications shall be released to reflect the change



TAI-SAW TECHNOLOGY CO., LTD.

No. 3, Industrial 2nd Rd., Ping-Chen Industrial District,
Taoyuan, 324, Taiwan, R.O.C.

TEL: 886-3-4690038 FAX: 886-3-4697532

E-mail: tstsales@mail.taisaw.com Web: www.taisaw.com

SAW DPX 1880/1960 MHz Band 2 SMD 1.8X1.4 mm (BW=59.04 MHz)
MODEL NO.:TF0121B REV.1.0

A. MAXIMUM RATING:

1. Operating temperature range: -40 °C to +85 °C
2. Storage temperature range: -50 °C to +125 °C
3. Input power : 29dBm (Ta=+50degC,50kh,CW)
4. Maximum DC Voltage: +/-3 V
5. Moisture Sensitivity Level: Level 1 (MSL 1)
6. ESD 50V(MM) 100V(HBM)

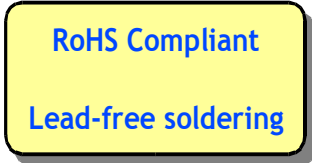

Electrostatic Sensitive Device (ESD)

B. ELECTRICAL CHARACTERISTICS:

Terminating impedance (Tx Port): 50 Ω (Single-ended)

Terminating impedance (Rx Port): 50 Ω (Single-ended)

Terminating impedance (Ant Port): 50//3.9nH Ω (Single-ended)

Tx to ANT (f_{T0}=1880 MHz)

Parameters Description		Unit	Min	Typ	Max	Remarks
Insertion Loss	1850.48~1909.52MHz	dB(*1)	-	1.9	3.0	-20 to+85 °C
	1852.4~1907.6MHz(*2)	dB(*1)	-	1.7	2.7	-20 to+85 °C
	1851.25~1908.75MHz(*3)	dB(*1)	-	1.8	2.9	
Amplitude ripple	1850.48~1909.52MHz	dB	-	1.5	2.2	
VSWR	ANT	-	-	1.6	2.0	
	Tx	1850.48~1909.52MHz	-	-	1.6	2.1
Attenuation:						
1570~1580 MHz		dB	35	38	-	
1930.48~1989.52 MHz		dB	42	51	-	-20 to+85 °C
1931.25~1988.75 MHz(*3)		dB	41	51	-	
3700~3820 MHz		dB	20	34	-	
5550~5730 MHz		dB	15	27	-	

ANT to Rx (f_{T0}=1960 MHz)

Parameters Description		Unit	Min	Typ	Max	Remarks
Insertion Loss	1930.48~1989.52MHz	dB(*1)		2.5	3.3	-20 to+85 °C
	1932.4~1987.6MHz(*2)	dB(*1)		2.2	3.0	-20 to+85 °C
	1931.25~1988.75MHz(*3)	dB(*1)		2.3	3.2	
Amplitude ripple	1930.48~1989.52MHz	dB		1.5	2.3	
VSWR	ANT	1930.48~1989.52MHz		1.6	2.1	
	Rx			1.9	2.2	
Attenuation:						
1850.48~1909.52MHz		dB	42	53	-	-20 to+85 °C
1851.25~1908.75MHz(*3)		dB	43	53	-	

Tx to Rx

Isolation	1850.48~1909.52 MHz	dB	51	54	-	-20 to+85 °C
	1851.25~1908.75 MHz(*3)	dB	51	54	-	
	1930.48~1989.52 MHz	dB	48	54	-	-20 to+25 °C
		dB	51	54	-	+25 to+85 °C
	1932.4~1987.6 MHz(*2)	dB	50	54	-	-20 to+25 °C
		dB	51	54	-	+25 to+85 °C
	1931.25~1988.75 MHz(*3)	dB	47	54	-	-30 to+25 °C
		dB	51	54	-	+25 to+85 °C

(*1) Specification of insertion loss excludes loss that comes from the test board.

(*2) The integrated loss over any 3.84MHz(+/- 1.92MHz) channel within the band.

(*3) The integrated loss over any 1.25MHz(+/- 0.625MHz) channel within the band.

C. FREQUENCY CHARACTERISTICS:

Tx to Ant

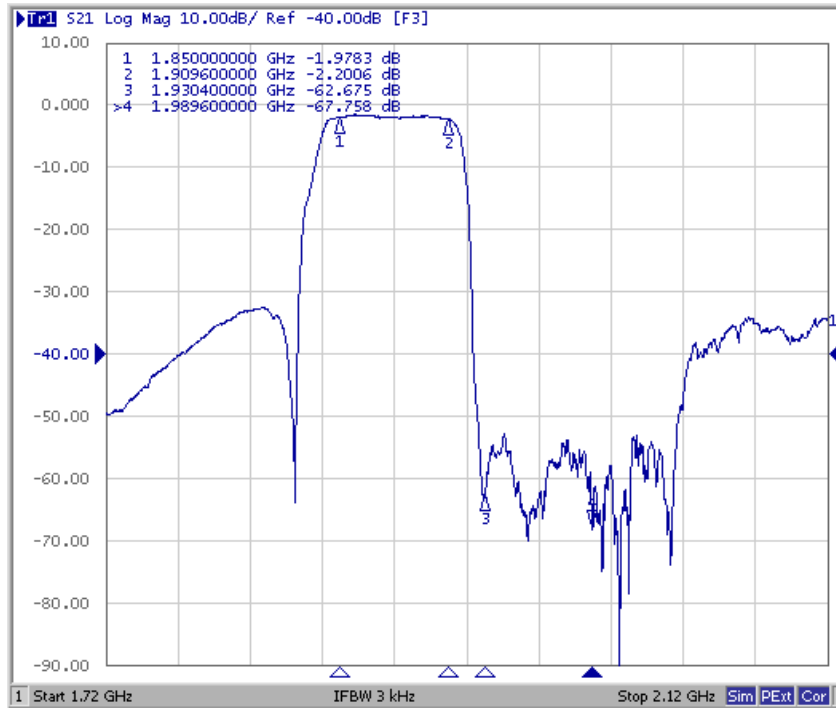

Ant to Rx

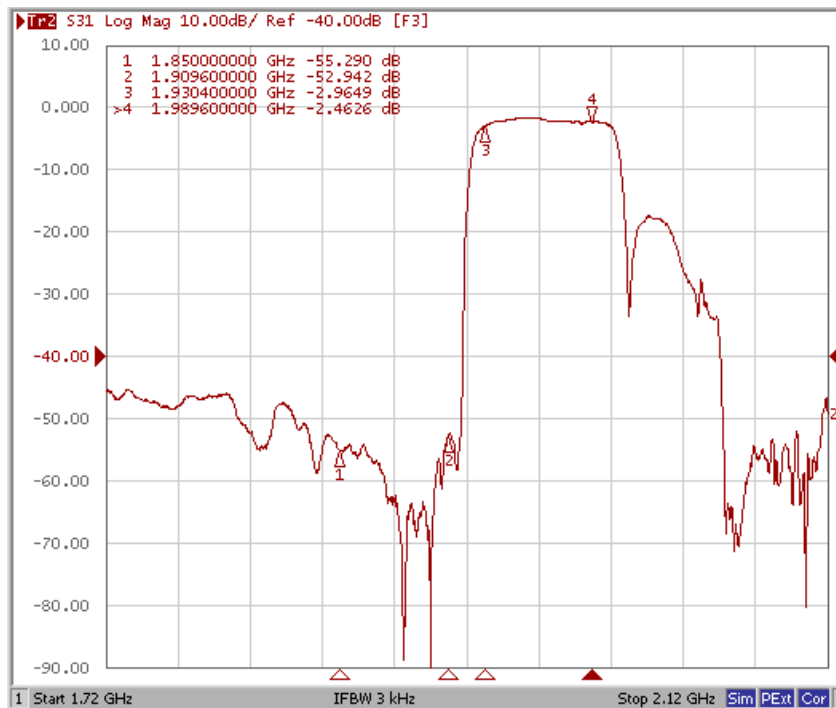

These data exclude loss that comes from the test board.

Tx to Ant ,Ant to Rx

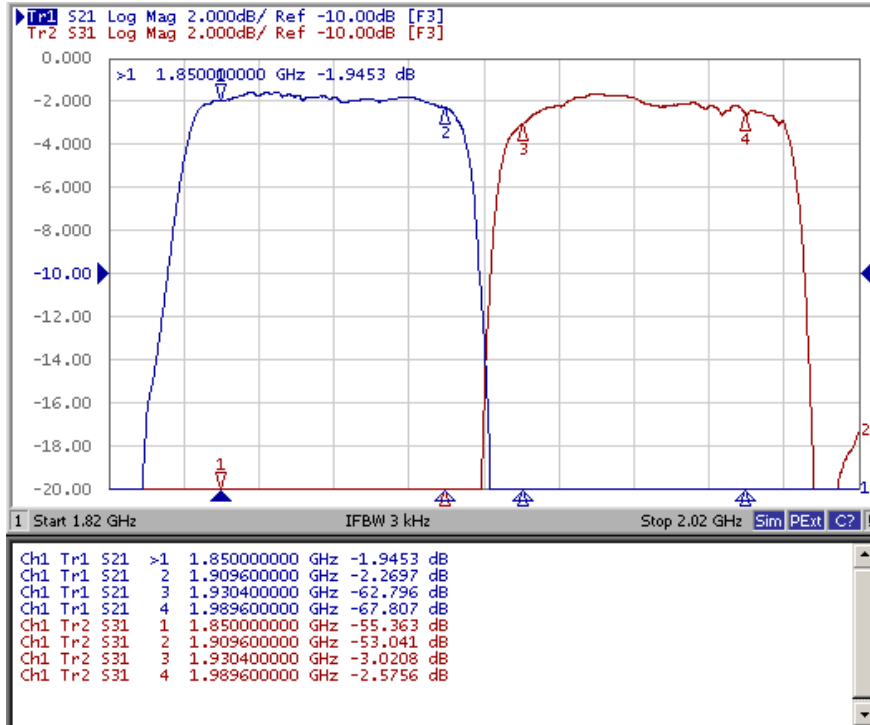

Tx to Rx Isolation

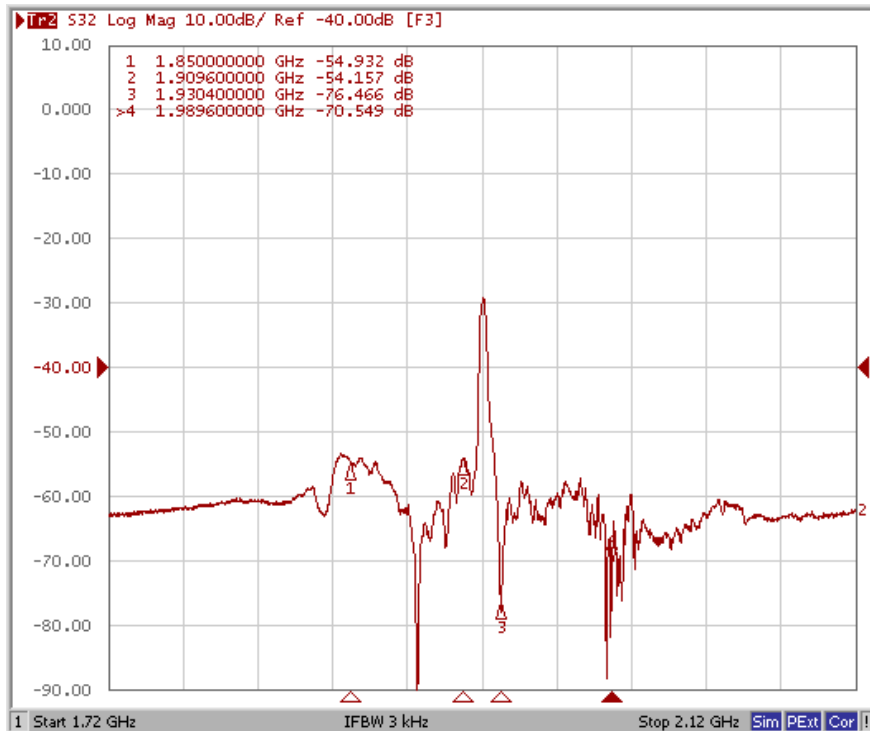

These data exclude loss that comes from the test board

Tx Port

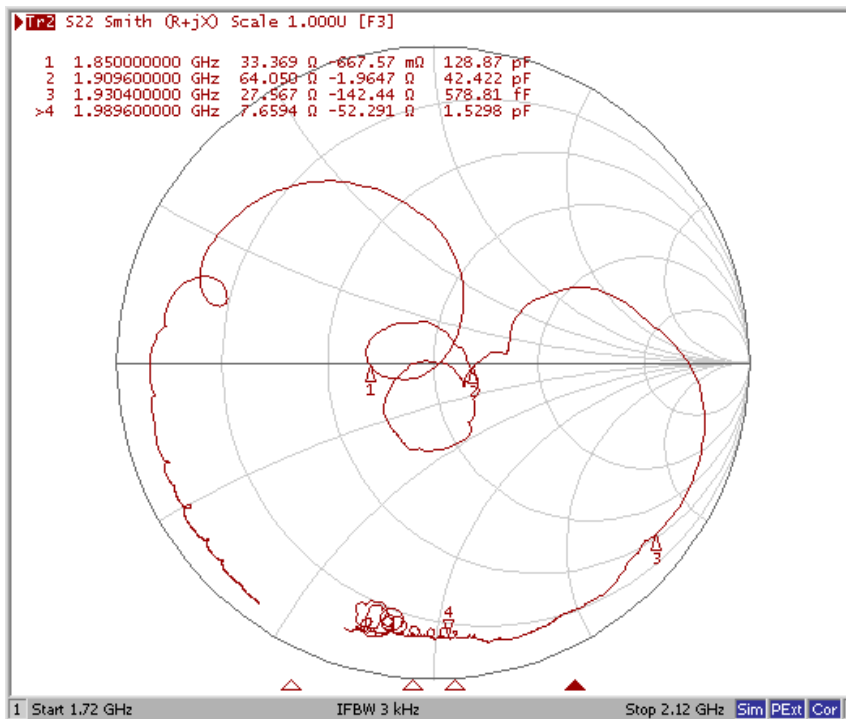
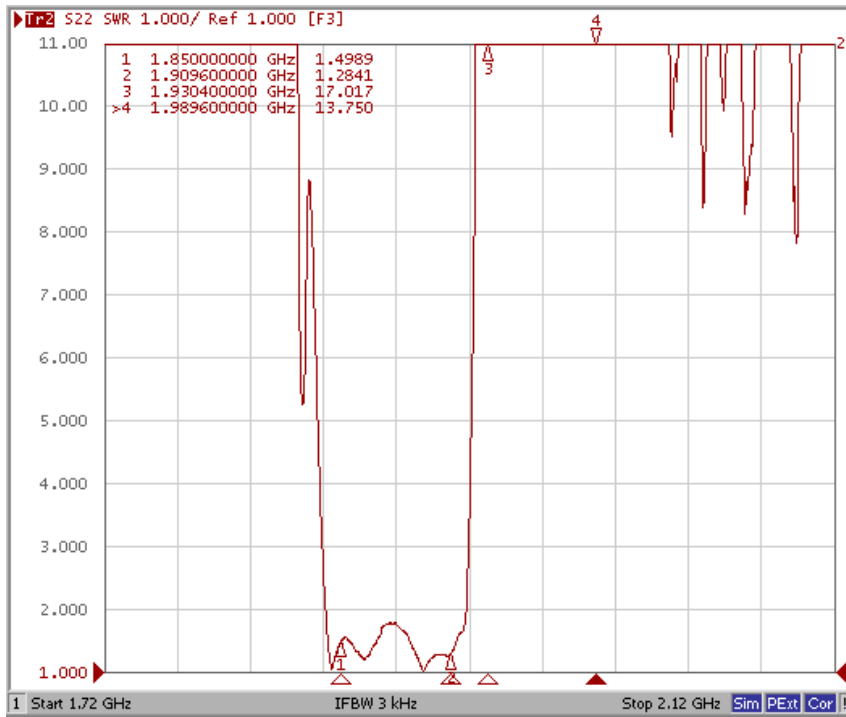

Rx Port

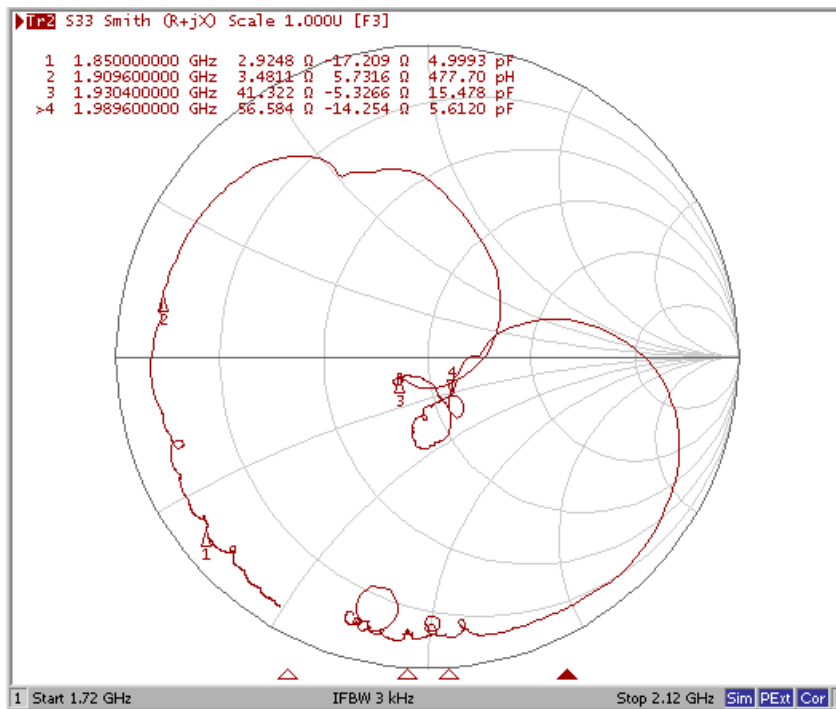
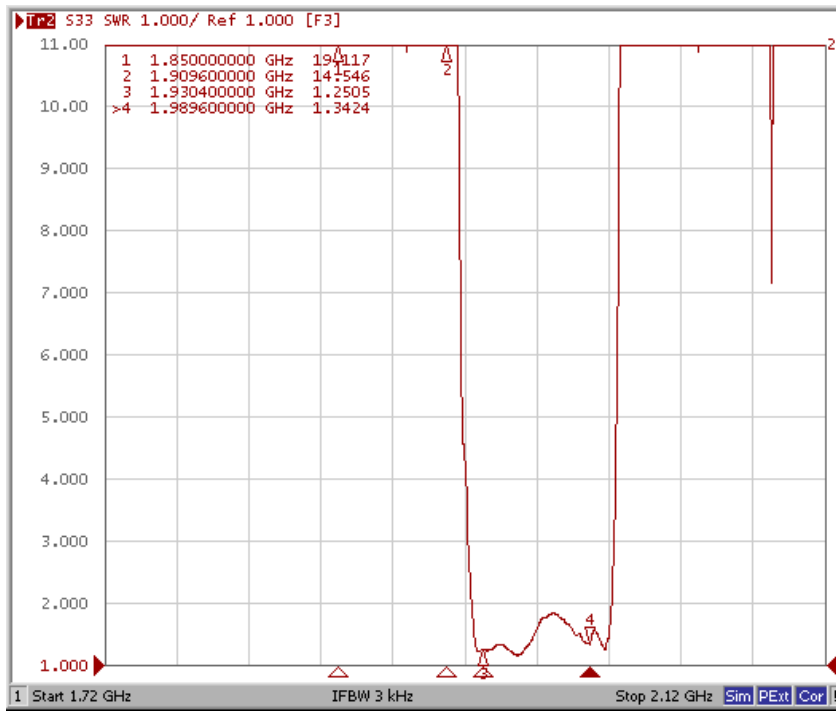

Ant Port

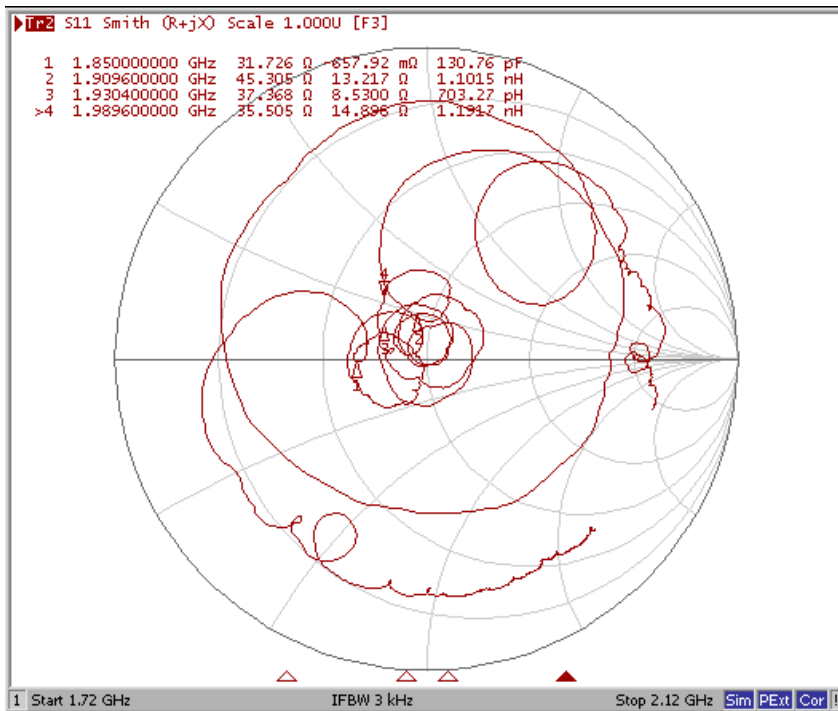
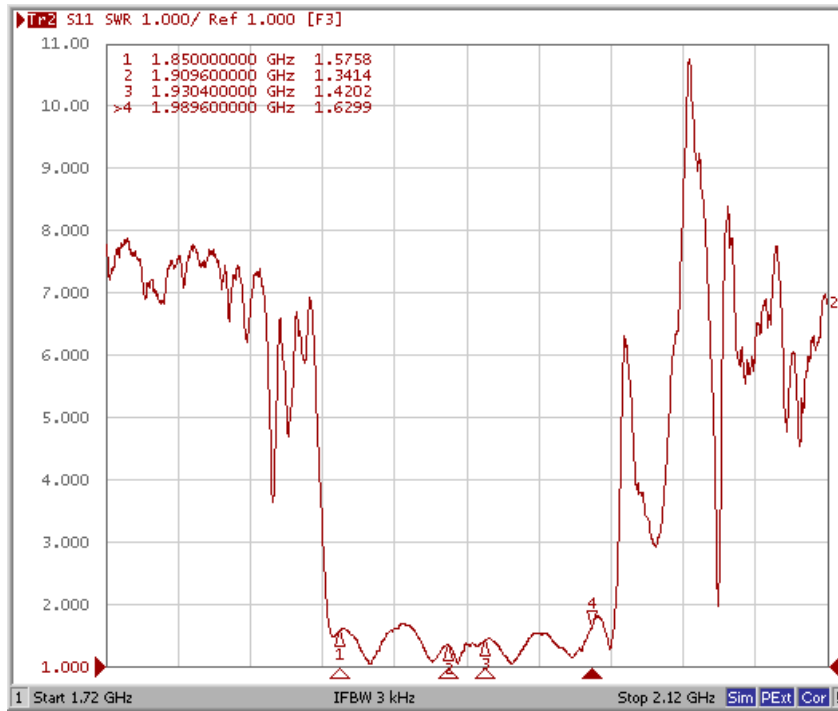

Tx to Ant (Wide span)

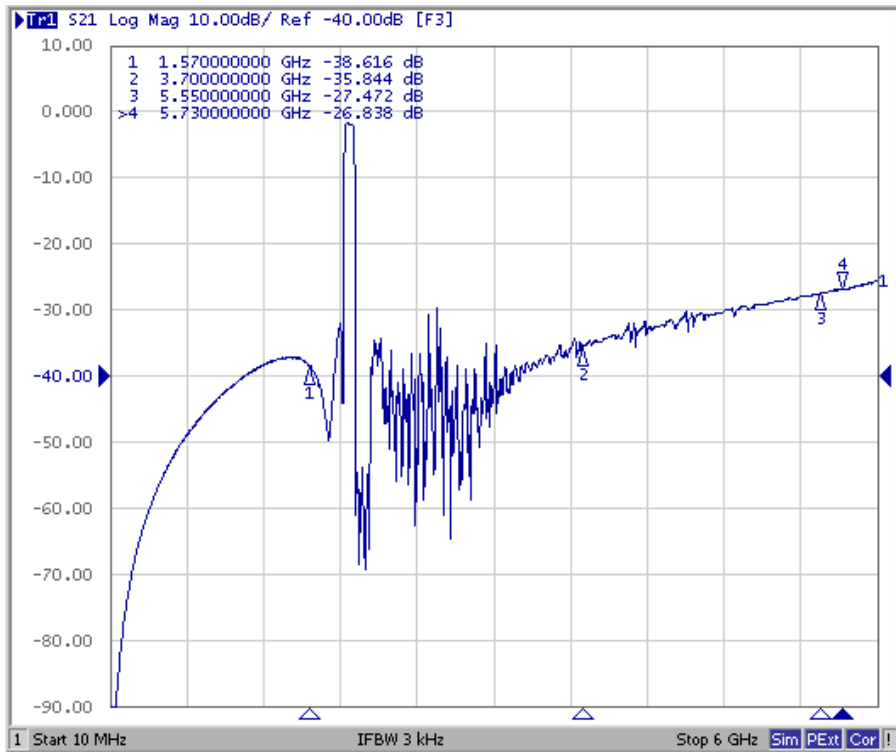

Ant to Rx (Wide span)

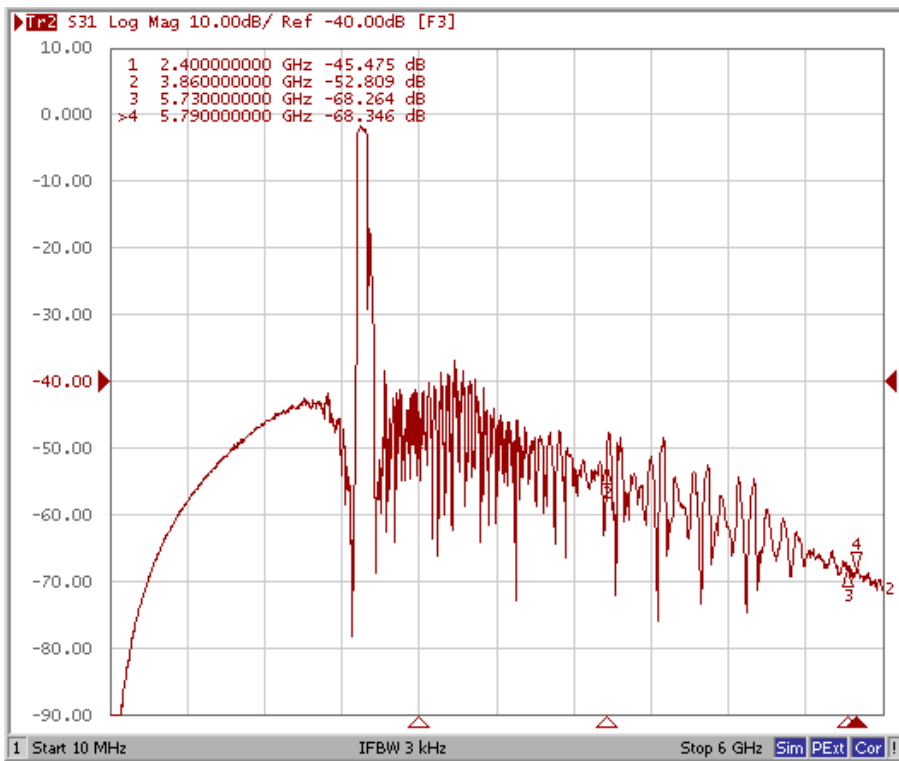

D.OUTLINE DRAWIN:

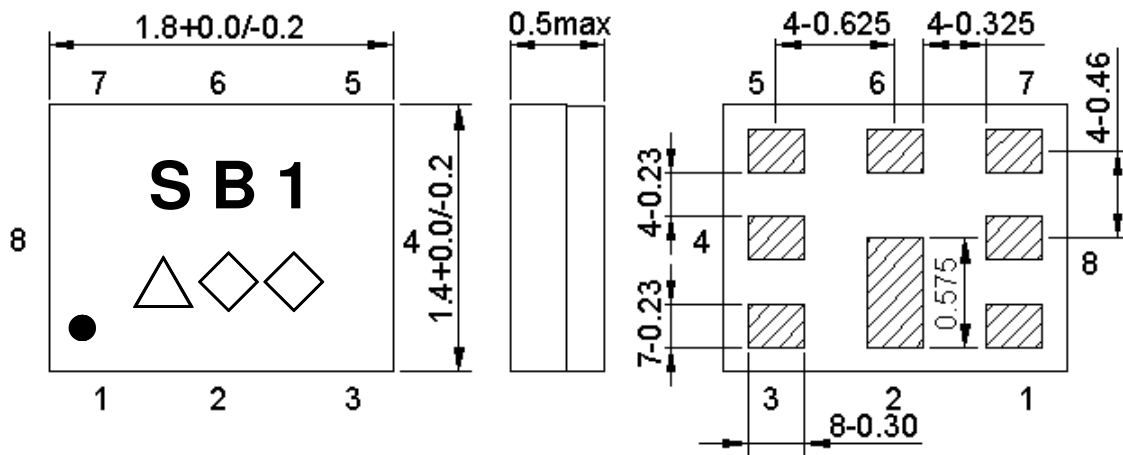

Marking name : **SB1**

△: Date code(2016 May → s ,....., 2019 Dec→m.)

◇◇: Lot Code.

Product Date Code. Follow below table.

Year	Jan	Feb	Mar	Apr	May	Jun	Jul	Aug	Sep	Oct	Nov	Dec
2016	n	p	q	r	s	t	u	v	w	x	y	z
2017	A	B	C	D	E	F	G	H	J	K	L	M
2018	N	P	Q	R	S	T	U	V	W	X	Y	Z
2019	a	b	c	d	e	f	g	h	j	k	l	m
2020	n	p	q	r	s	t	u	v	w	x	y	z
2021	A	B	C	D	E	F	G	H	J	K	L	M

Pin Configuration

Pin No.	Pin name	Description
1	Rx	Receiver Pin
2	GND	Ground Pin
3	Tx	Transmitter Pin
4	GND	Ground Pin
5	GND	Ground Pin
6	ANT	Antenna Pin
7	GND	Ground Pin
8	GND	Ground Pin

Figure 1. Dimensions and Pin assignment

E.Evaluation Circuit

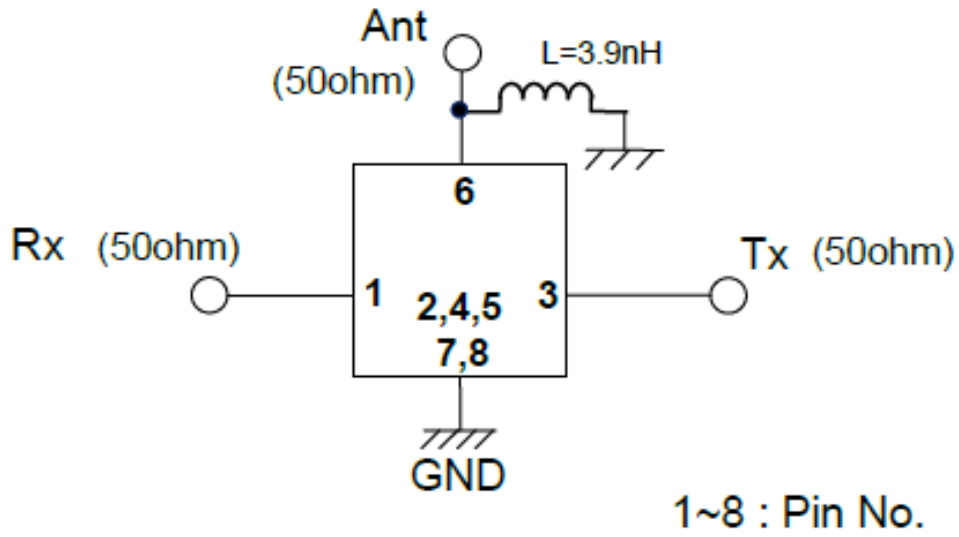

F. FOOTPRINT:

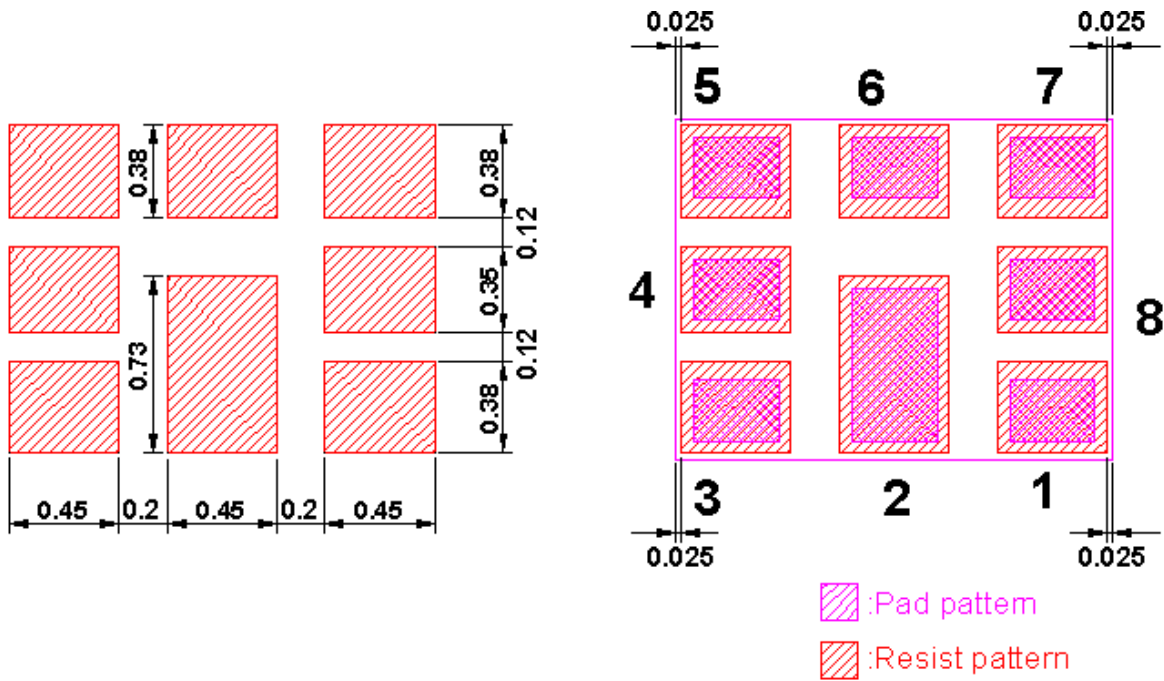

G. PACKING:

1. REEL DIMENSION

(Please refer to FR-75D10 for packing quantity)

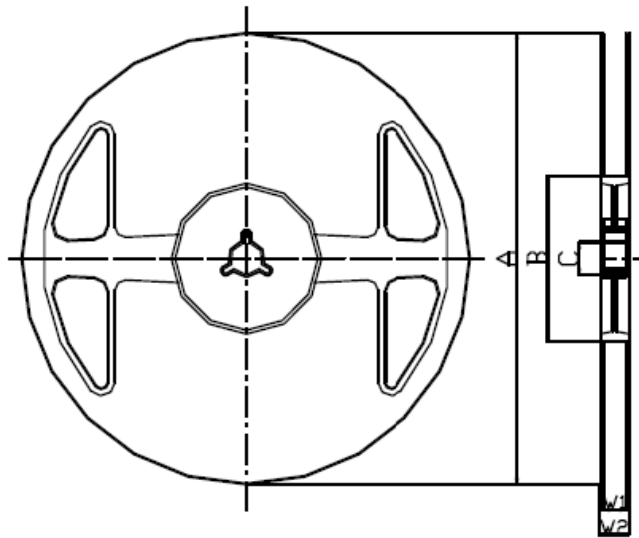

Materials of Reel

Material : Polystyrene + Carbon

Characteristics : Conforms to EIAJ-ET-7200A

Color : Black

Surface resistance (reference value) : $10^9\Omega/\text{sq Max.}$

Unit : mm

Code	Quantity	A	B	C	W1	W2
Z	3,000 pcs	$\phi 180.0 +0.0/-1.5$	$\phi 66.0 +/-0.5$	$\phi 13.0 +/-0.2$	$9.0 +1.0/-0.0$	$11.4 +/-1.0$

2. TAPE DIMENSION

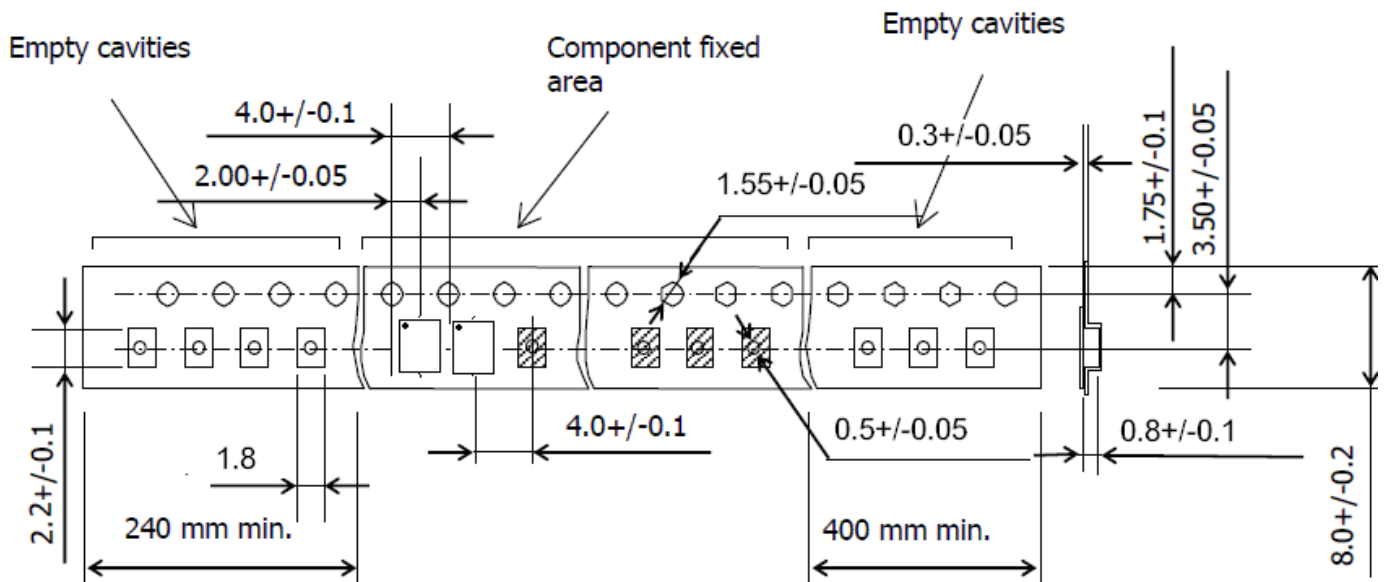

Unit : mm

H. RECOMMENDED REFLOW PROFILE → Direction of feed

1. Preheating shall be fixed at 150~180°C for 60~90 seconds.
2. Ascending time to preheating temperature 150°C shall be 30 seconds min.
3. Heating shall be fixed at 220°C for 50~80 seconds and at 245~260°C peak (min. 10sec).
4. Time : 2 times.

