



TAI-SAW TECHNOLOGY CO., LTD.

No. 3, Industrial 2nd Rd., Ping-Chen Industrial District,
Taoyuan, 324, Taiwan, R.O.C.

TEL: 886-3-4690038 FAX: 886-3-4697532

E-mail: tstsales@mail.taisaw.com Web: www.taisaw.com

Product Specifications Approval Sheet

Product Description: SAW DPX 1733/2133 MHz LTE Band 4 SMD 1814

TST Part No.: TF0122A

Customer Part No.: _____

Customer signature required
Company: _____
Division: _____
Approved by : _____
Date: _____

Checked by: _____ Anne Chen 

Approved by: _____ Bob Chau 

Date: _____ 2017, 04, 10

1. Customer signed back is required before TST can proceed with sample build and receive orders.
2. Orders received without customer signed back will be regarded as agreement on the specifications.
3. Any specifications changes must be approved upon by both parties and a new revision of specifications shall be released to reflect the change



TAI-SAW TECHNOLOGY CO., LTD.

No. 3, Industrial 2nd Rd., Ping-Chen Industrial District,
Taoyuan, 324, Taiwan, R.O.C.

TEL: 886-3-4690038 FAX: 886-3-4697532

E-mail: tstsales@mail.taisaw.com Web: www.taisaw.com

SAW DPX 1733/2133 MHz LTE Band 4 SMD 1814 (45 MHz BW)

MODEL NO.:TF0122A

REV.No.:2

A. MAXIMUM RATING:

1. Operating temperature range: -20 °C to +85 °C
2. Storage temperature range: -20 °C to +85 °C
3. Input power : 29dBm (Ta=+50degC,50kh,CW)
4. Maximum DC Voltage: +/-3 V
5. Moisture Sensitivity Level: Level 1
6. ESD 50V(MM) 100V(HBM)

RoHS Compliant
Lead free
Lead-free soldering

Electrostatic Sensitive Device (ESD)

B. ELECTRICAL CHARACTERISTICS:

Terminating impedance (Tx Port): 50//9.1nH Ω(Single-ended)

Terminating impedance (Rx Port): 50 Ω (Single-ended)

Terminating impedance (Ant Port): 50//4.3nH Ω (Single-ended)

Tx to ANT (f_{T0}=1733 MHz)

Parameters Description		Unit	Min	Typ	Max	Remarks
Insertion Loss	1710~1755MHz	dB(*1)	-	1.5	2.0	
Amplitude ripple	1710~1755MHz	dB	-	0.6	1.2	
VSWR	Tx	-	-	1.6	2.0	
	ANT	-	-	1.6	2.0	
Attenuation:						
1559~1585.42 MHz		dB	40	43	-	
2110~2155 MHz		dB	44	52	-	
2400~2500 MHz		dB	36	42	-	
3420~3510 MHz		dB	29	35	-	
5130~5265 MHz		dB	21	28	-	

ANT to Rx ($f_{T0}=2133$ MHz)

Parameters Description		Unit	Min	Typ	Max	Remarks
Insertion Loss	2110~2155 MHz	dB(*1)	-	1.7	2.2	
Amplitude ripple	2110~2155 MHz	dB	-	0.4	1.0	
VSWR	ANT	-		1.5	2.0	
	Rx			1.6	2.0	
Attenuation:						
1710~1755 MHz		dB	44	50	-	
2400~2500 MHz		dB	35	41	-	
3820~3910 MHz		dB	36	43	-	

Tx to Rx

Isolation	1710~1755 MHz	dB	52	57	-	
	2110~2155 MHz	dB	50	55	-	

(*1) Specification of insertion loss excludes loss that comes from the test board.

C.Evaluation Circuit

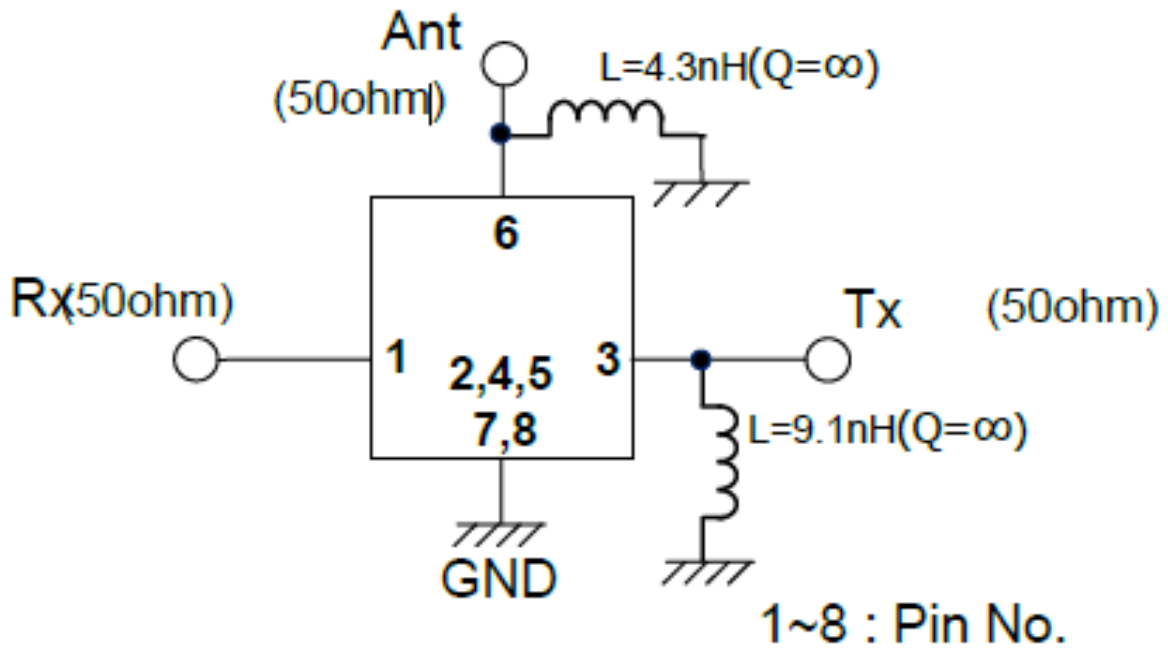

D. FREQUENCY CHARACTERISTICS:

Tx to Ant

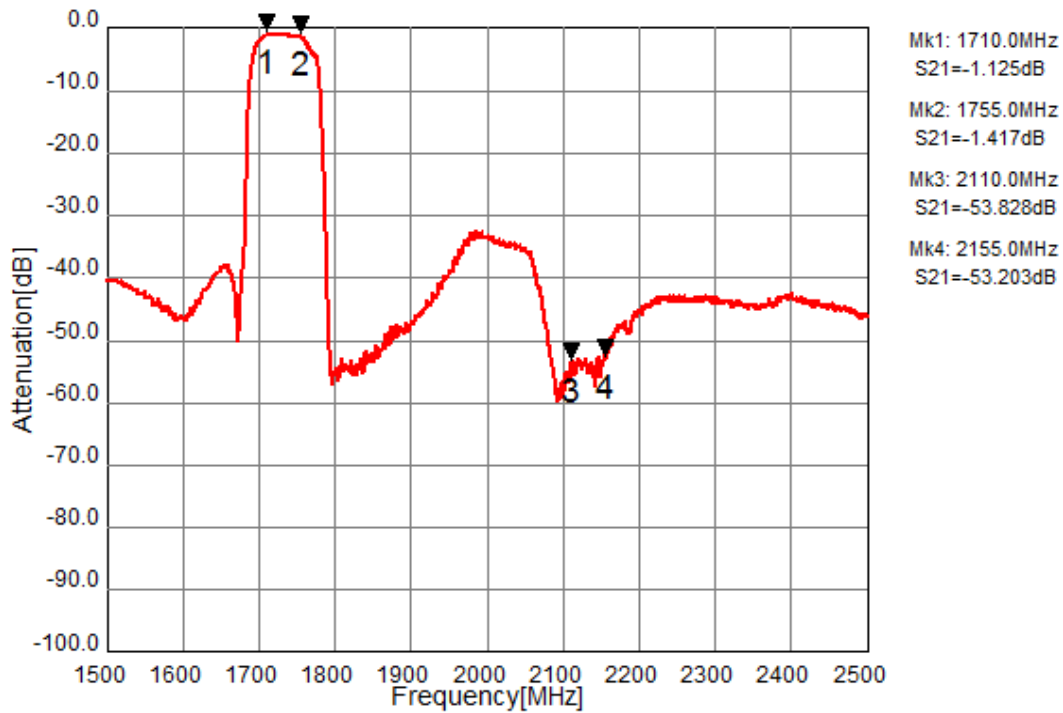

Ant to Rx

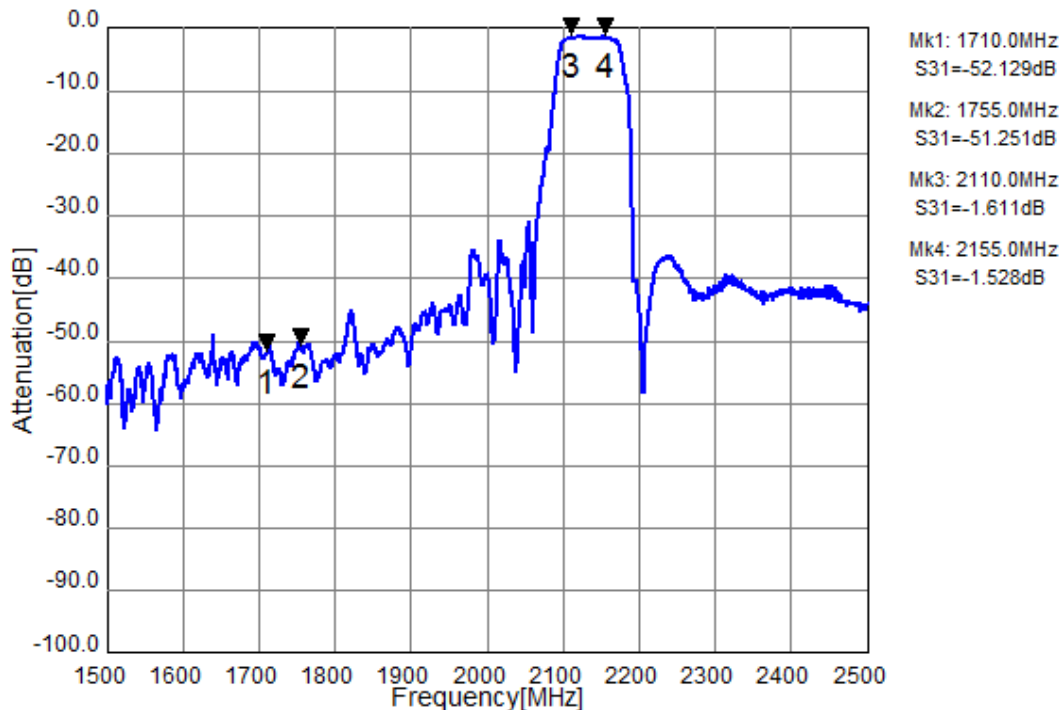
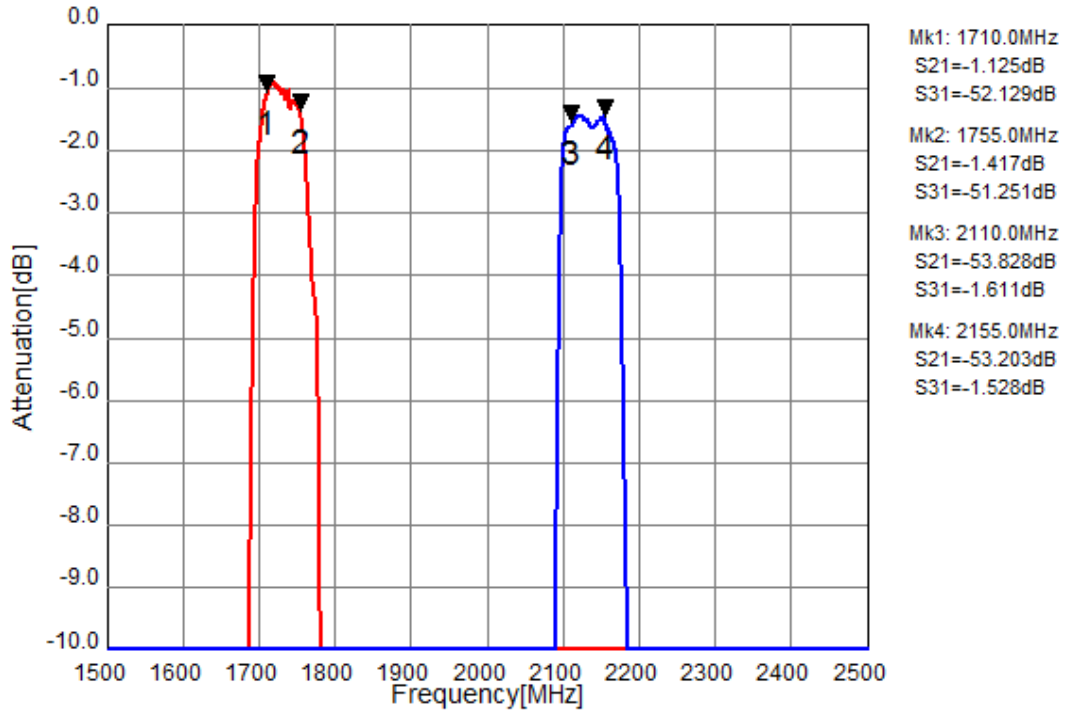

Figure 3-1. Electrical Characteristics

These data **exclude** loss that comes from the test board.

Tx to Ant ,Ant to Rx



Tx to Rx Isolation

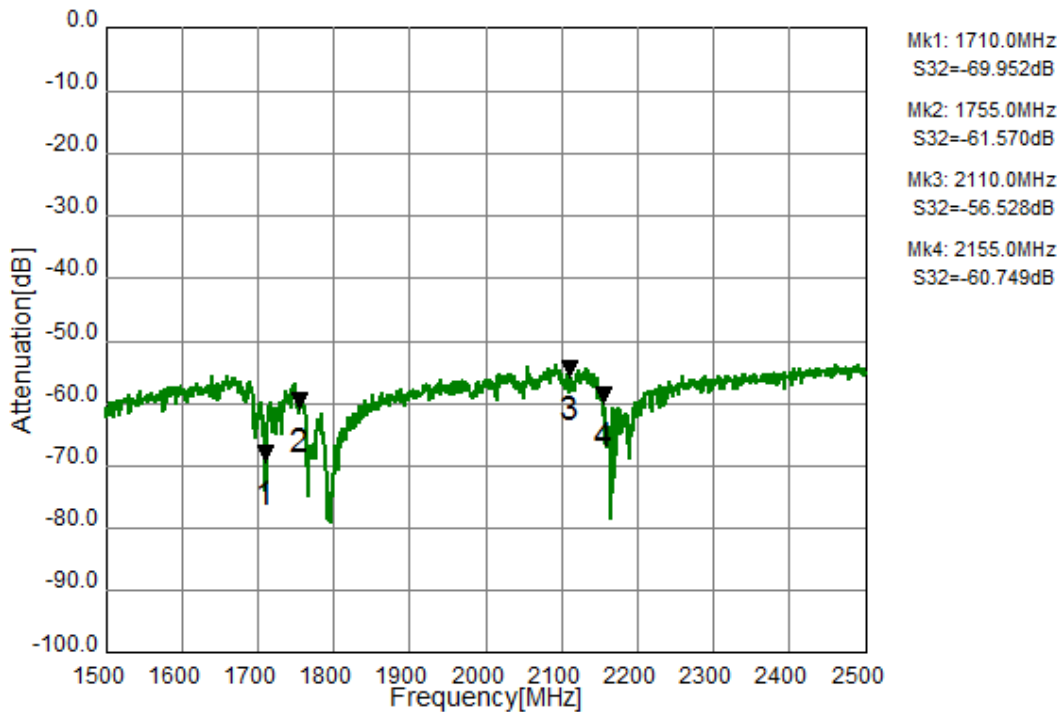

Figure 3-2. Electrical Characteristics
 These data **exclude** loss that comes from the test board

Tx Port

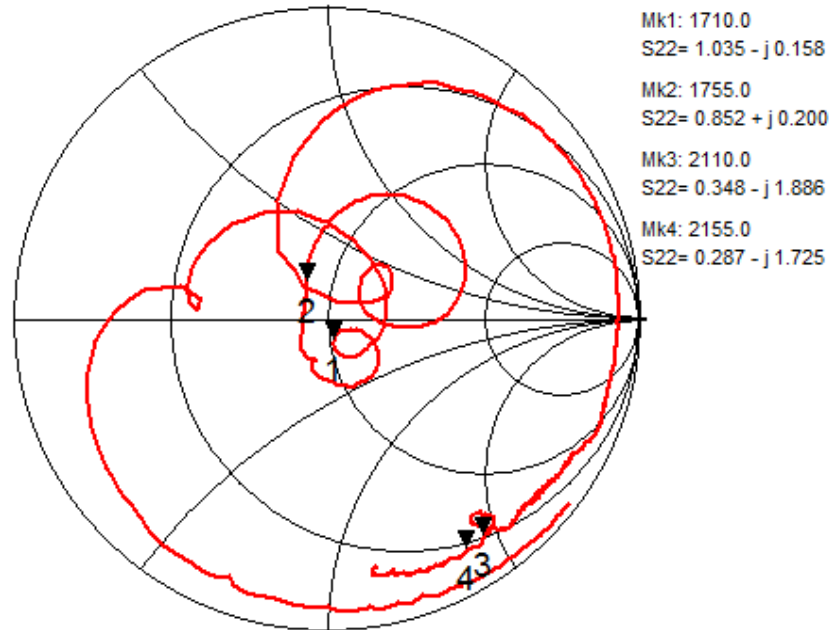
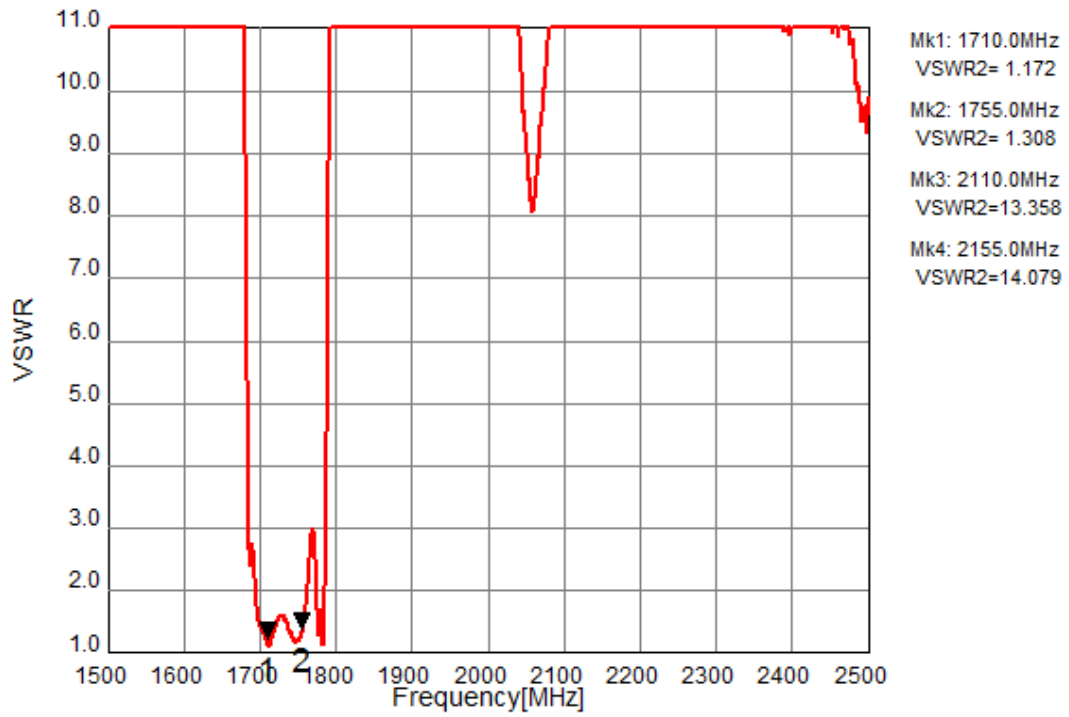

Figure 3-3. Electrical Characteristics

Rx Port

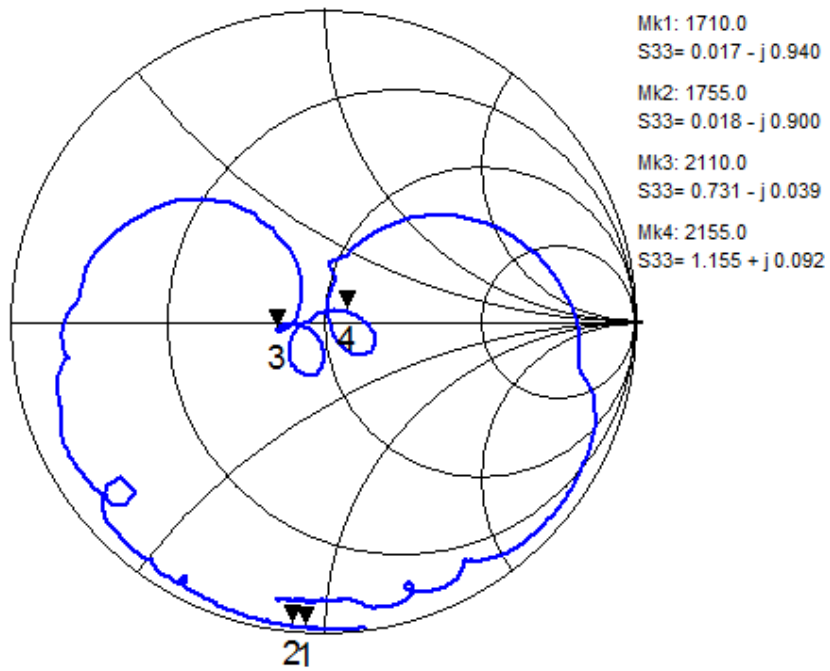
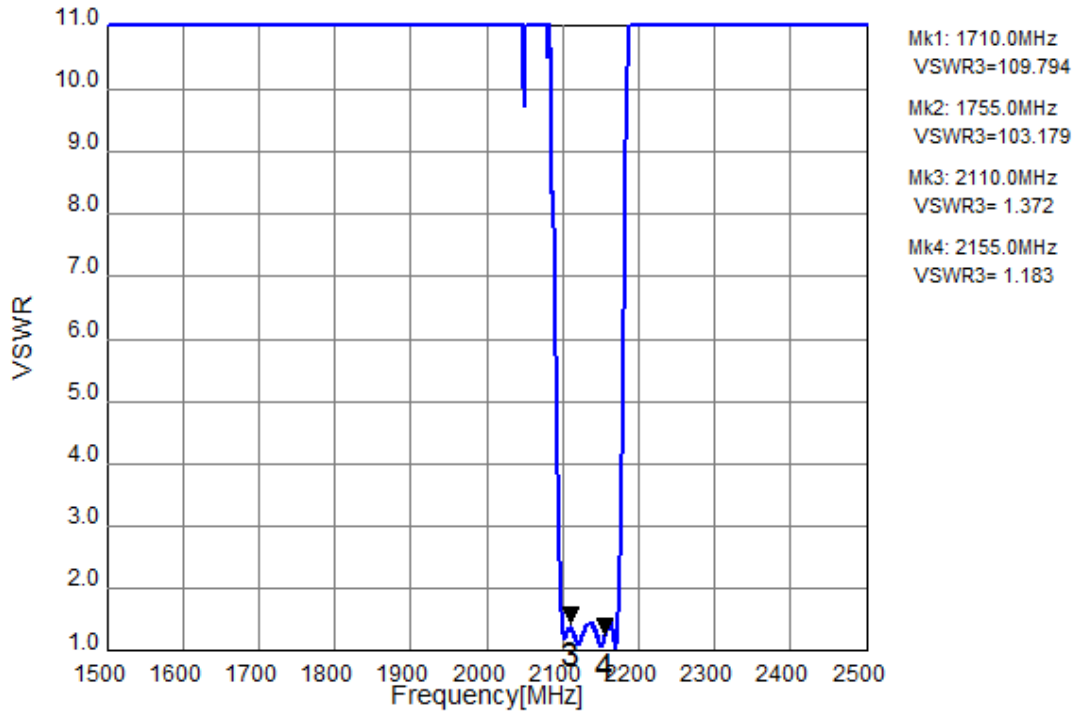

Figure 3-4. Electrical Characteristics

Ant Port

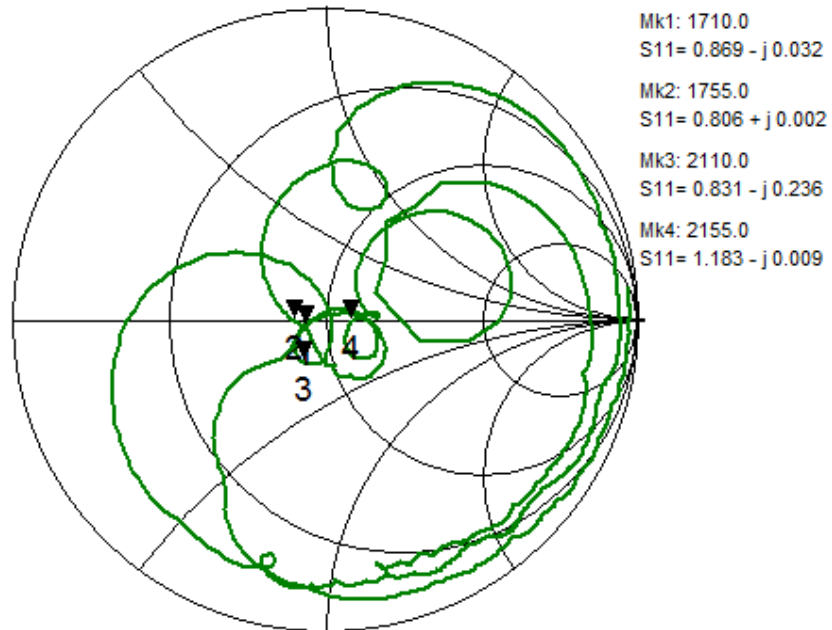
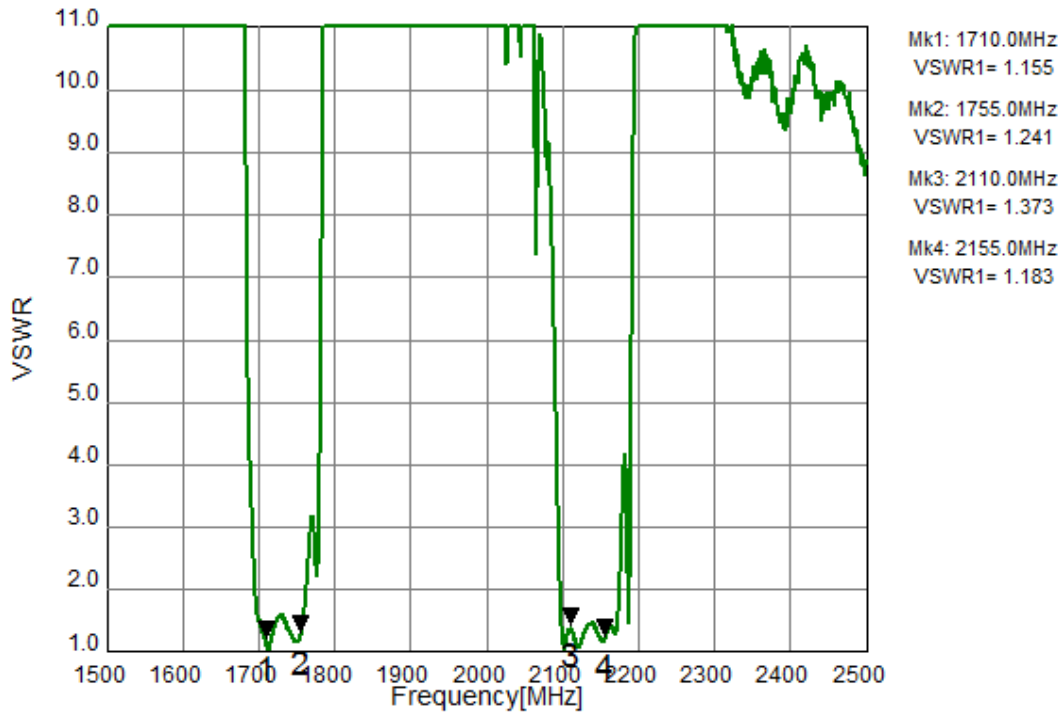
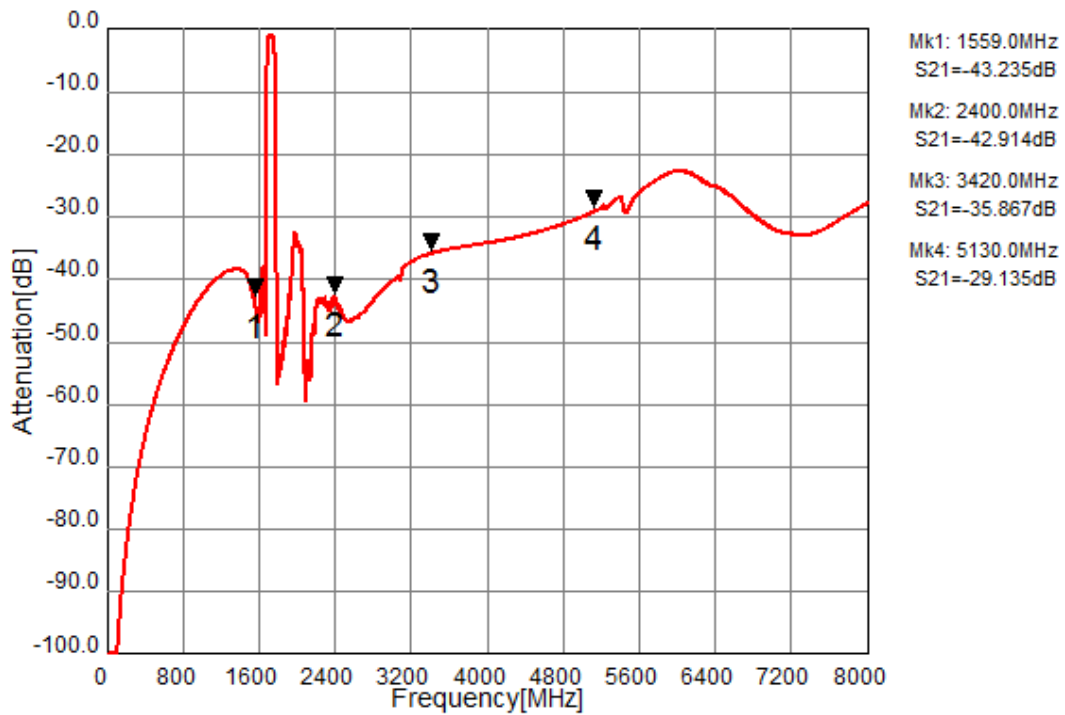

Figure 3-5. Electrical Characteristics

Tx to Ant (Wide span)



Ant to Rx (Wide span)

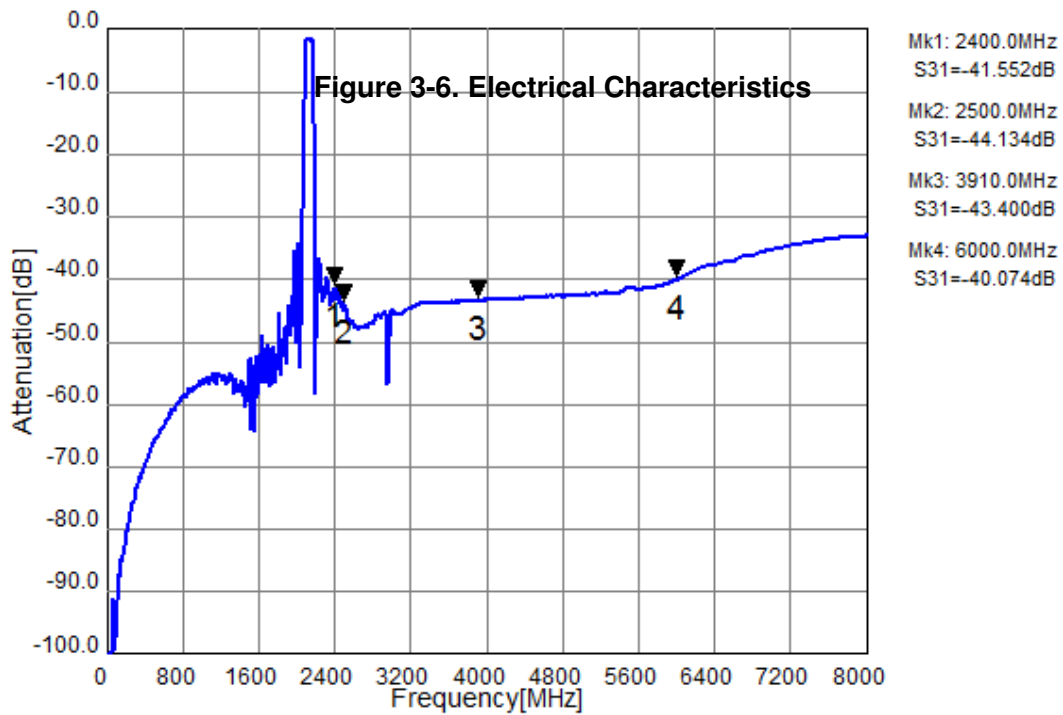
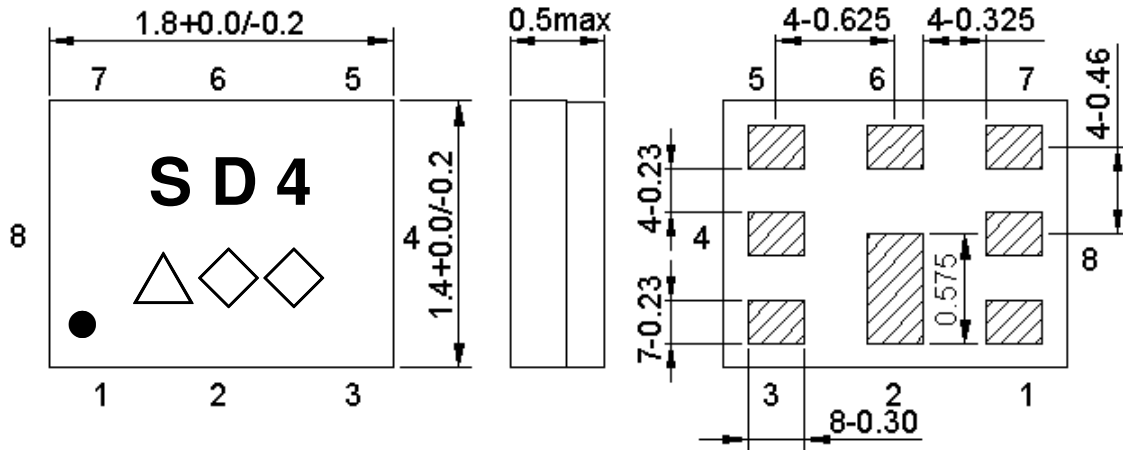

Figure 3-6. Electrical Characteristics

E. OUTLINE DRAWIN:



Marking name : **SD4**

△ : Date code(2016 May → s ,....., 2019 Dec→m.)

◇◇: Lot Code.

Product Date Code. Follow below table.

Year	Jan	Feb	Mar	Apr	May	Jun	Jul	Aug	Sep	Oct	Nov	Dec
2016	n	p	q	r	s	t	u	v	w	x	y	z
2017	A	B	C	D	E	F	G	H	J	K	L	M
2018	N	P	Q	R	S	T	U	V	W	X	Y	Z
2019	a	b	c	d	e	f	g	h	j	k	l	m

Pin Configuration:

Pin No.	Pin Name	Description
1	Rx	Receive Pin
2	GND	Ground Pin
3	Tx	Transmitter Pin
4	GND	Ground Pin
5	GND	Ground Pin
6	ANT	Antenna Pin
7	GND	Ground Pin
8	GND	Ground Pin

F. FOOTPRINT:

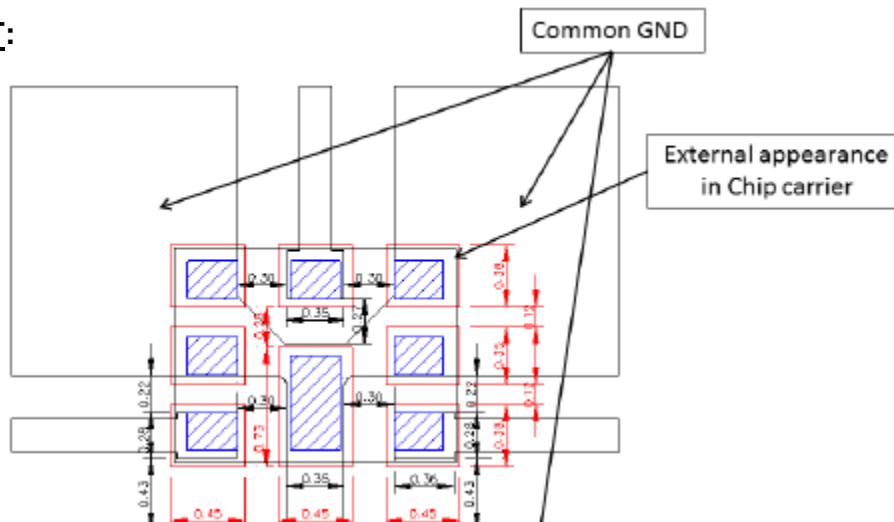

G. PACKING:

1. REEL DIMENSION

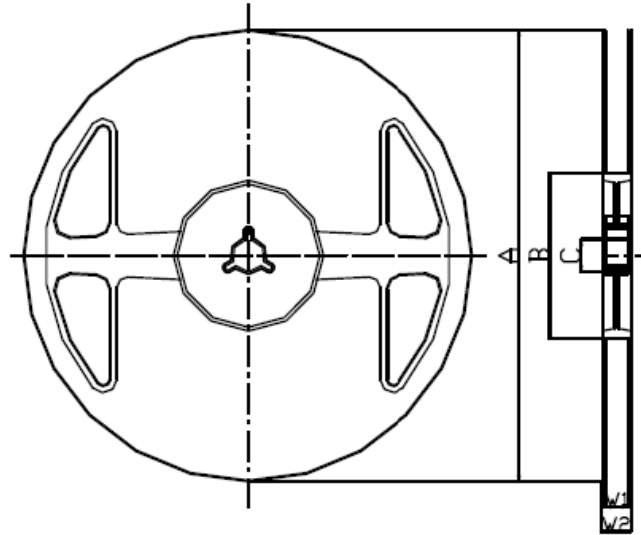

Materials of Reel

Material : Polystyrene + Carbon

Characteristics : Conforms to EIAJ-ET-7200A

Color : Black

Surface resistance (reference value) : $10^9\Omega/\text{sq Max.}$

Unit : mm

Code	Quantity	A	B	C	W1	W2
Z	3,000 pcs	$\phi 180.0 +0.0/-1.5$	$\phi 66.0 +/-0.5$	$\phi 13.0 +/-0.2$	$9.0 +1.0/-0.0$	$11.4 +/-1.0$

2. TAPE DIMENSION

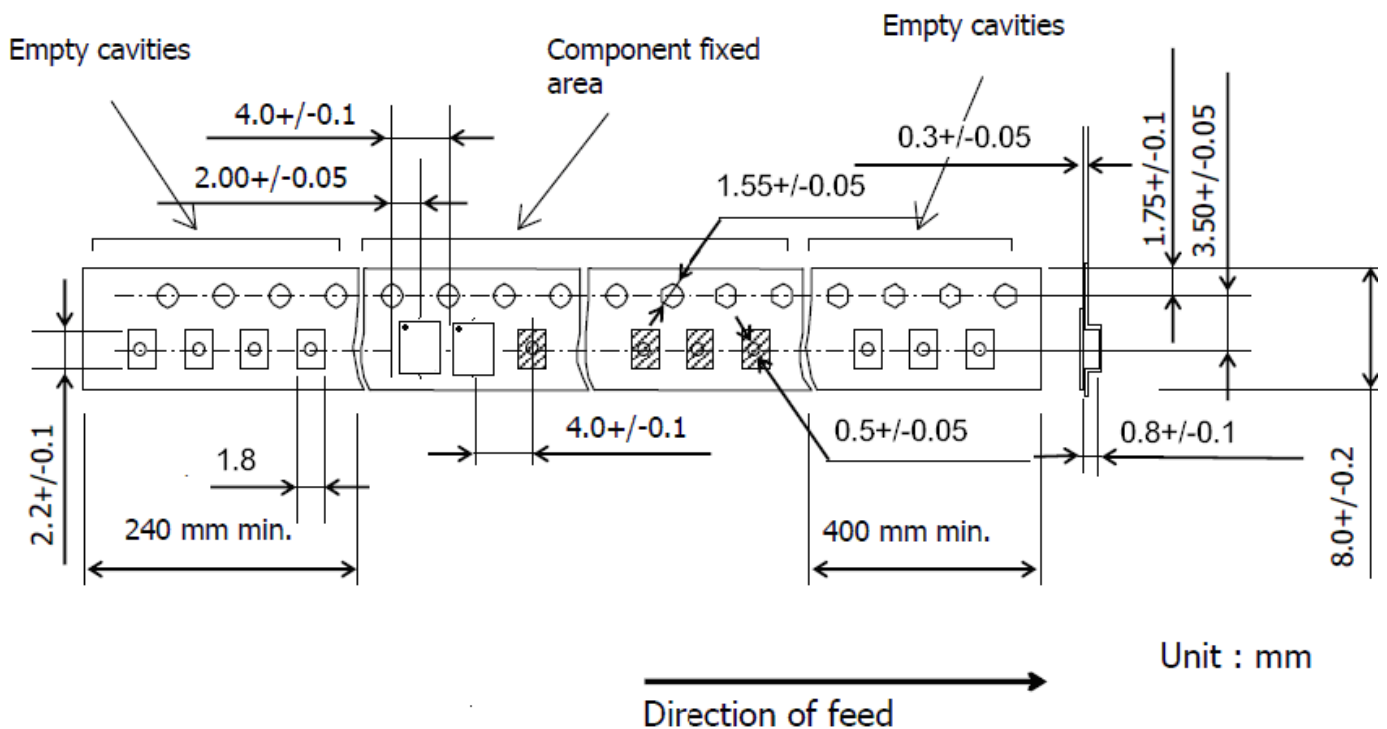

Unit : mm

H. RECOMMENDED REFLOW PROFILE :

1. Preheating shall be fixed at 150~180°C for 60~90 seconds.
2. Ascending time to preheating temperature 150°C shall be 30 seconds min.
3. Heating shall be fixed at 220°C for 50~80 seconds and at 245~260°C peak (min. 10sec).
4. Time : 2 times.

