



TAI-SAW TECHNOLOGY CO., LTD.

No. 3, Industrial 2nd Rd., Ping-Chen Industrial District,
Taoyuan, 324, Taiwan, R.O.C.

TEL: 886-3-4690038 FAX: 886-3-4697532

E-mail: tstsales@mail.taisaw.com Web: www.taisaw.com

Product Specifications Approval Sheet

Product Description: BAW DPX 2535/2655 MHz LTE Band 7 SMD 1.8X1.4 mm (BW=70 MHz)

TST Part No.: TF0124A

Customer Part No.: _____

Customer signature required
Company: _____
Division: _____
Approved by : _____
Date: _____

Checked by: _____ Anne Chen *Anne Chen*

Approved by: _____ Andy Yu *Andy Yu*

Date: _____ 05, 10, 2018

1. Customer signed back is required before TST can proceed with sample build and receive orders.
2. Orders received without customer signed back will be regarded as agreement on the specifications.
3. Any specifications changes must be approved upon by both parties and a new revision of specifications shall be released to reflect the change



TAI-SAW TECHNOLOGY CO., LTD.

No. 3, Industrial 2nd Rd., Ping-Chen Industrial District,
Taoyuan, 324, Taiwan, R.O.C.

TEL: 886-3-4690038 FAX: 886-3-4697532

E-mail: tstsales@mail.taisaw.com Web: www.taisaw.com

BAW DPX 2535/2655 MHz Band 7 SMD 1.8X1.4 mm (BW=70 MHz)

MODEL NO.:TF0124A

REV.3.0

A. MAXIMUM RATING:

1. Operating temperature range: -40 °C to +85 °C
2. Storage temperature range: -40 °C to +85 °C
3. Input power : 29dBm (Ta=+50deg C,5khours,CW)
4. Maximum DC Voltage: +/-3 V
5. Moisture Sensitivity Level: Level 1

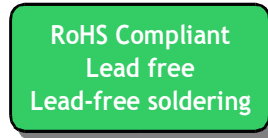

Electrostatic Sensitive Device (ESD)

B. ELECTRICAL CHARACTERISTICS:

Terminating impedance (Tx Port): 50 Ω(Single-ended)

Terminating impedance (Rx Port): 50 Ω (Single-ended)

Terminating impedance (Ant Port): 50//3.2nH Ω (Single-ended)

Tx to ANT (f_{T0}=2535 MHz)

Parameters Description		Unit	Min	Typ	Max	Remarks
Insertion Loss	2500~2570MHz	dB(*1)	-	2.3	2.9	2500~2510MHz
		dB(*1)		1.7	2.7	2510~2570MHz
Ripple	2500~2570MHz	dB	-	1.2	2.3	
Ripple(any 5MHz)	2500~2570MHz	dB		0.5	1.0	
VSWR	ANT	-	-	1.6	2.4	
	Tx	-	-	1.8	2.5	

Attenuation:

10~1565.42 MHz	dB	35	40	-	
832~862 MHz	dB	45	51	-	
1226~1250 MHz	dB	38	44	-	
1559~1563 MHz	dB	35	40	-	
1565.42~1573.374 MHz	dB	35	40	-	
1573.374~1577.466 MHz	dB	35	40		
1577.466~1585.42 MHz	dB	35	40		
1597.5515~1605.886 MHz	dB	35	40		
1605.886~1680 MHz	dB	35	39		
1710~1785 MHz	dB	33	38		
1805~1880 MHz	dB	33	38		
1710~1755 MHz	dB	33	38		
1900~1920 MHz	dB	32	37		
2010~2025 MHz	dB	32	37		

2110~2170 MHz	dB	32	36		
2402~2470 MHz	dB(*2)	40	47		
2440~2460 MHz	dB(*2)	40	44		
2474 MHz	dB	28	43		
2402~2467 MHz	dB(*3)	35	45		
2474~2500 MHz	dB	1	2.3		
2620~2690 MHz	dB	45	52		
4900~5950 MHz	dB	35	50		
5000~5140 MHz	dB	40	51		
5100~5280 MHz	dB	40	52		
7500~7710 MHz	dB	27	44		
2401~2423 MHz	dB(*2)	45	51		Ch1
2406~2428 MHz	dB(*2)	48	53		Ch2
2411~2433 MHz	dB(*2)	47	53		Ch3
2416~2438 MHz	dB(*2)	45	51		Ch4
2421~2443 MHz	dB(*2)	41	49		Ch5
2426~2448 MHz	dB(*2)	41	47		Ch6
2431~2453 MHz	dB(*2)	40	46		Ch7
2436~2458 MHz	dB(*2)	40	45		Ch8
2441~2463 MHz	dB(*2)	40	44		Ch9
2446~2468 MHz	dB(*2)	40	44		Ch10
2451~2473 MHz	dB(*2)	40	45		Ch11
2456~2478 MHz	dB(*2)	33	46		Ch12
2461~2483 MHz	dB(*2)	23	40		Ch13

ANT to Rx (f_{T0}=2655 MHz)

Parameters Description		Unit	Min	Typ	Max	Remarks
Insertion Loss	2620~2690 MHz	dB(*1)	-	2.2	2.6	
VSWR	ANT	-		1.7	2.3	
	Rx	-		1.8	2.3	
Attenuation:						
1~2500 MHz		dB	40	43	-	
45 MHz		dB	60	99	-	
718~748 MHz		dB	51	58		
814~849 MHz		dB	50	56		
832~862 MHz		dB	50	56		
880~915 MHz		dB	50	55		
1710~1785 MHz		dB	40	45		
1920~1980 MHz		dB	40	44		
2400~2500 MHz		dB	40	48		
2402~2470 MHz		dB	44	48		
2500~2570 MHz		dB	45	57		
2570~2600 MHz		dB	1	8		
2775~2790 MHz		dB	37	64		
2775~6000 MHz		dB	40	47		
4900~5300 MHz		dB	47	59		
5300~5950 MHz		dB	40	58		
7620~7830 MHz		dB	40	48		
7860~8070 MHz		dB	40	47		

Tx to Rx

Isolation	2500~2570 MHz	dB	55	58	-	
	2620~2690 MHz	dB	52	57	-	
	1574~1577 MHz	dB	50	70		
	5000~5140 MHz	dB	32	57		
	7500~7710MHz	dB	25	48		

(*1) Specification of insertion loss excludes loss that comes from the test board.

(*2) Integrated attenuation per 22MHz

(*3) Integrated attenuation per 18MHz

C. Evaluation Circuit

Evaluation Circuit

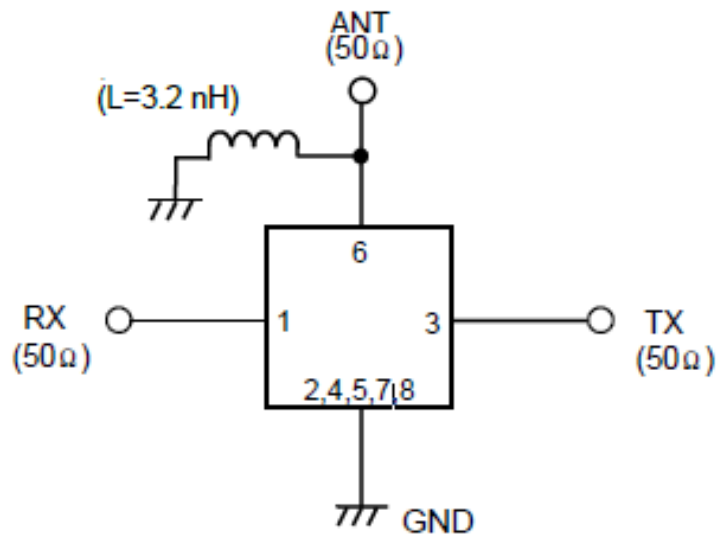

D. FOOTPRINT:

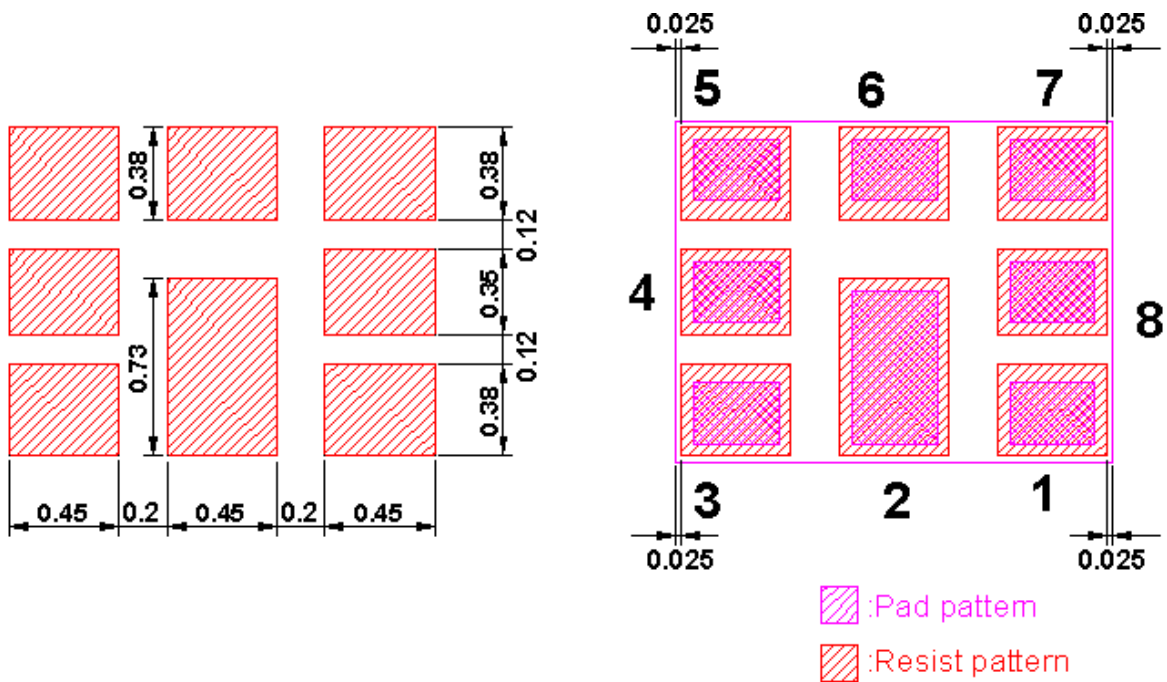

E. FREQUENCY CHARACTERISTICS:

Tx to Ant

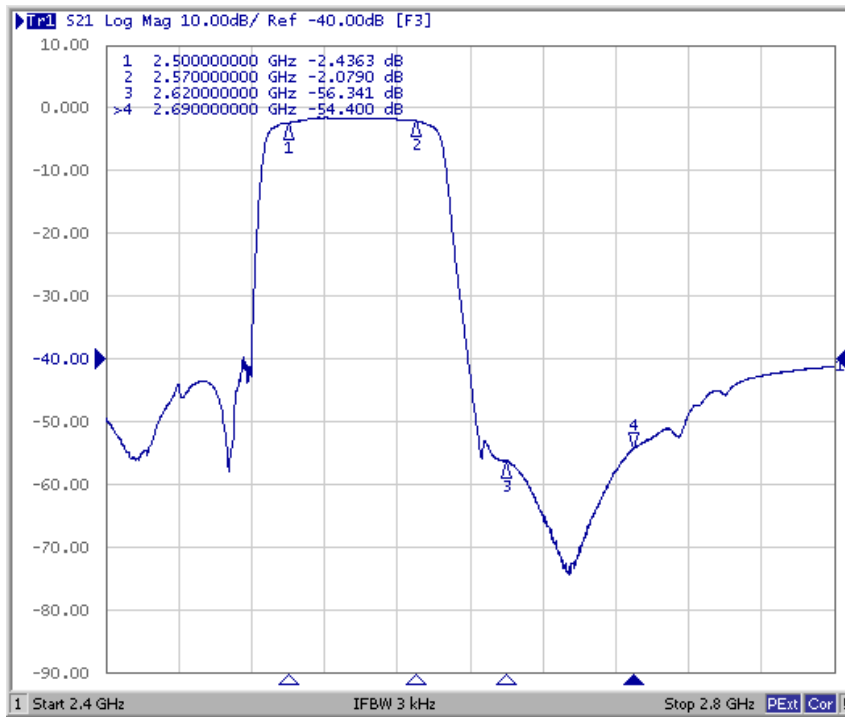

Ant to Rx

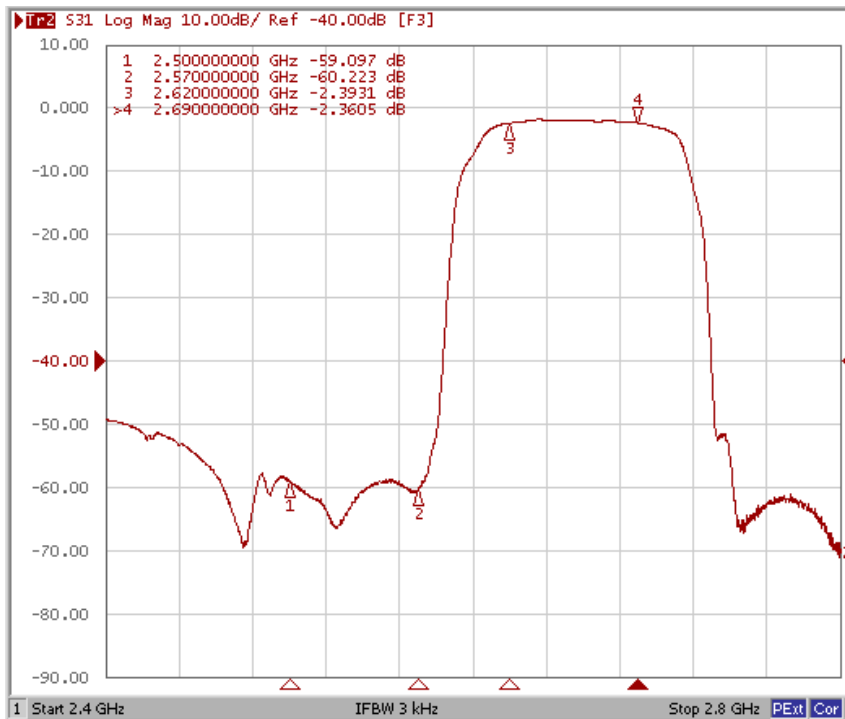

These data **exclude** loss that comes from the test board.

Tx to Ant ,Ant to Rx

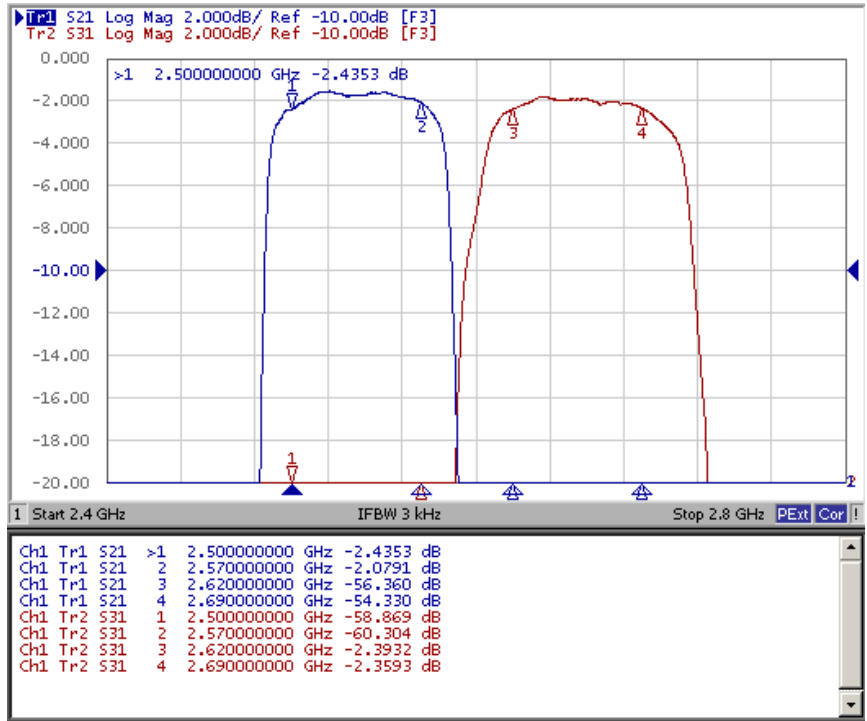

Tx to Rx Isolation

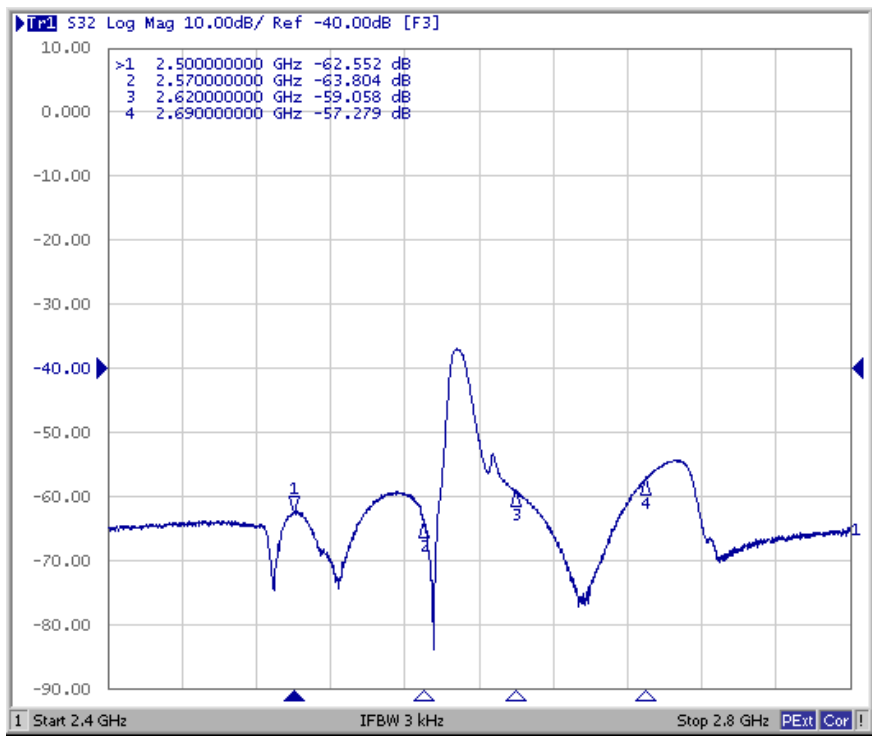

These data **exclude** loss that comes from the test board

Tx Port

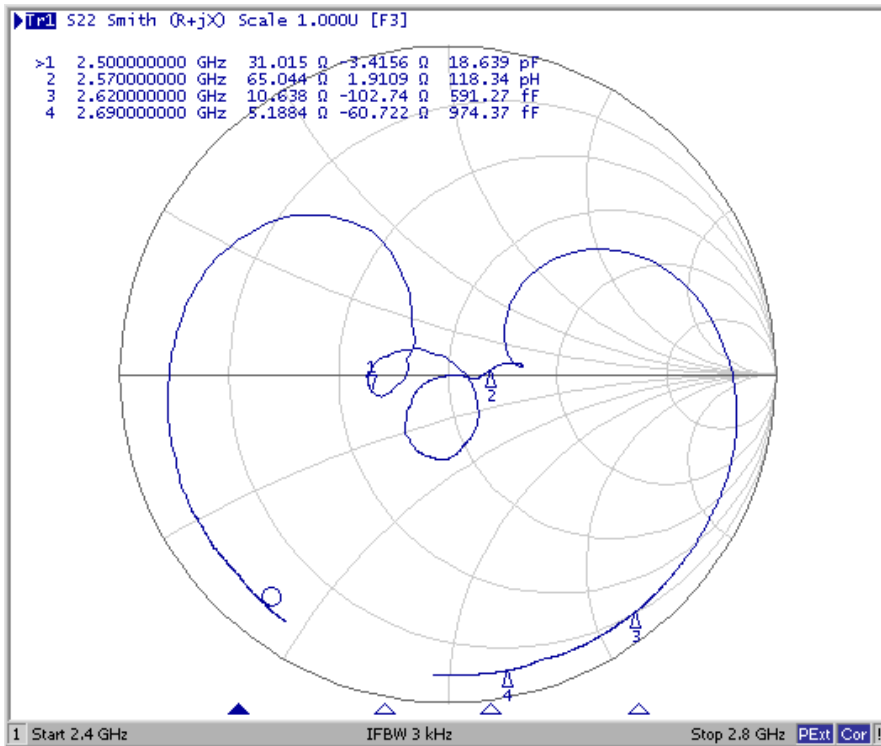
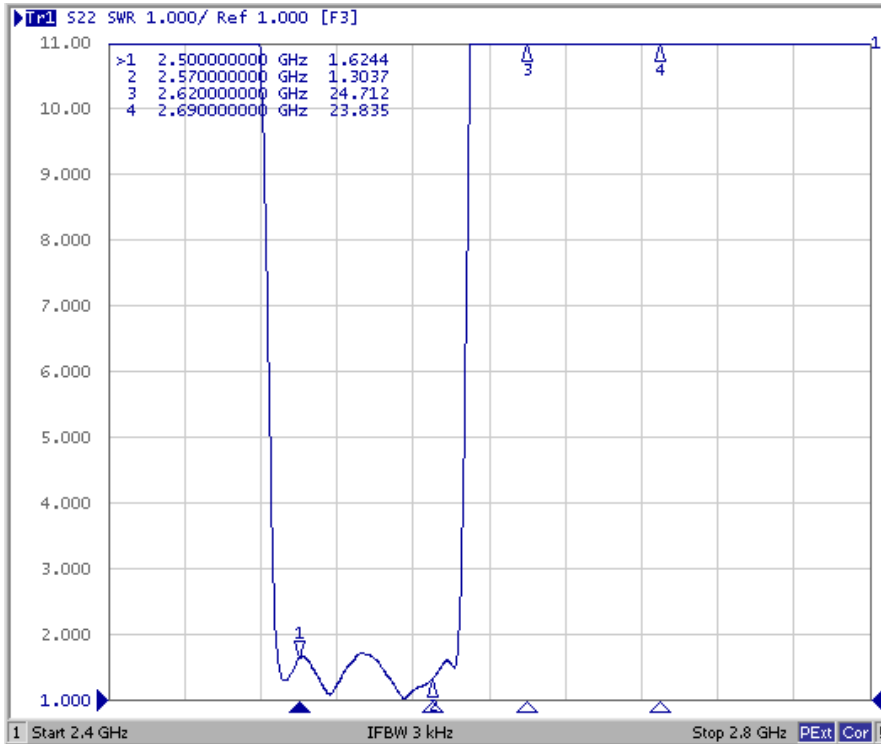

Rx Port

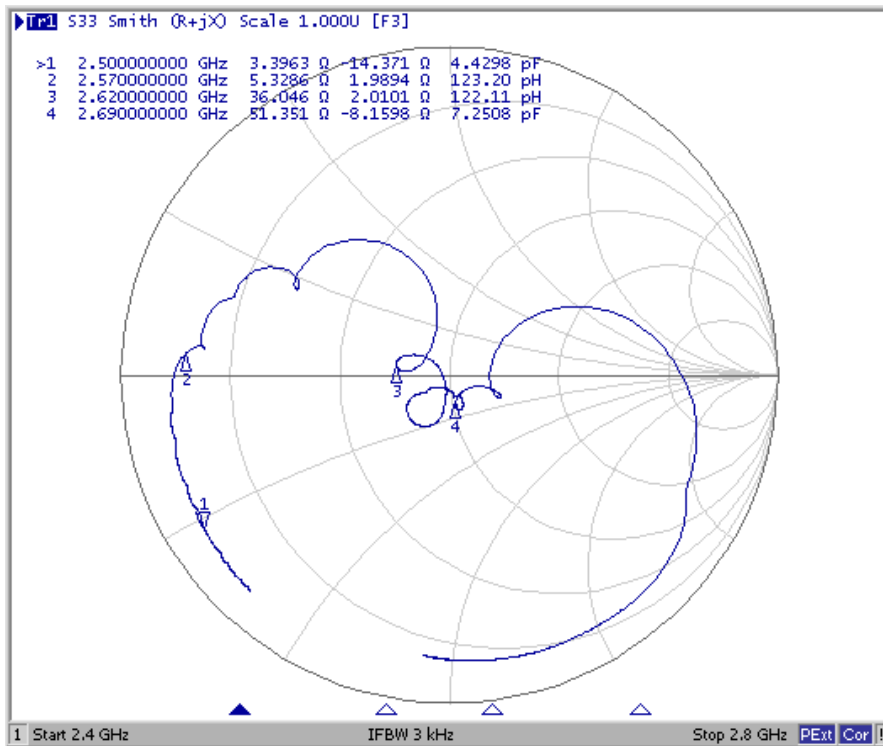
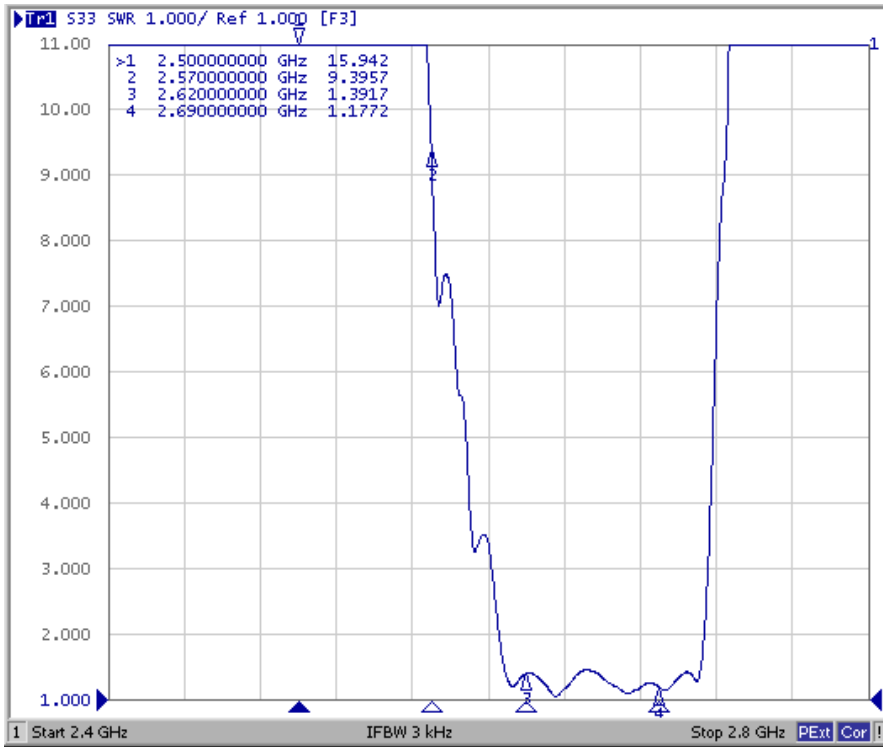

Ant Port

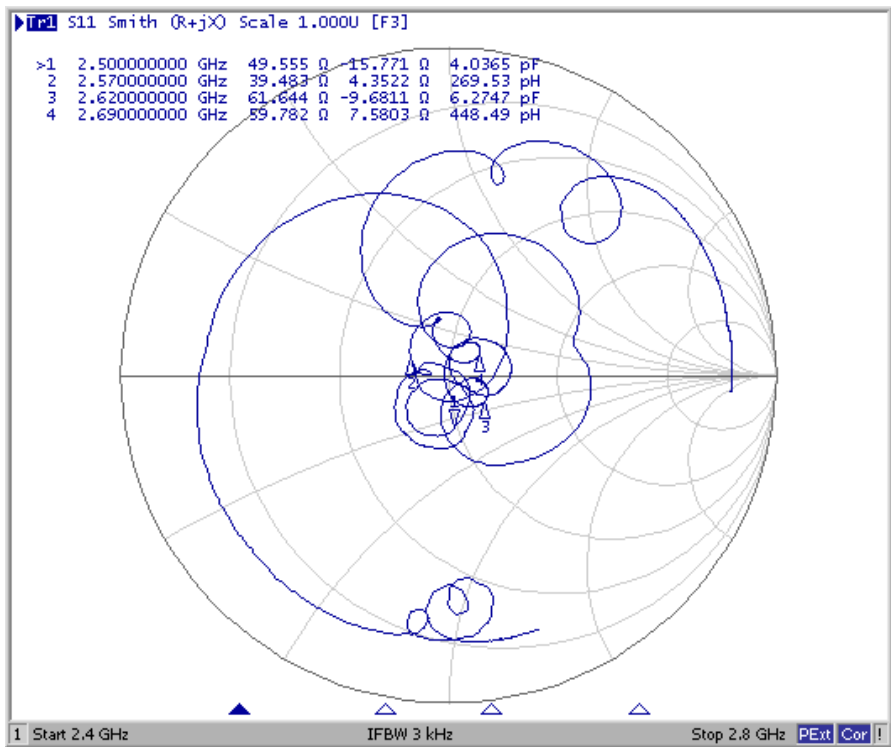
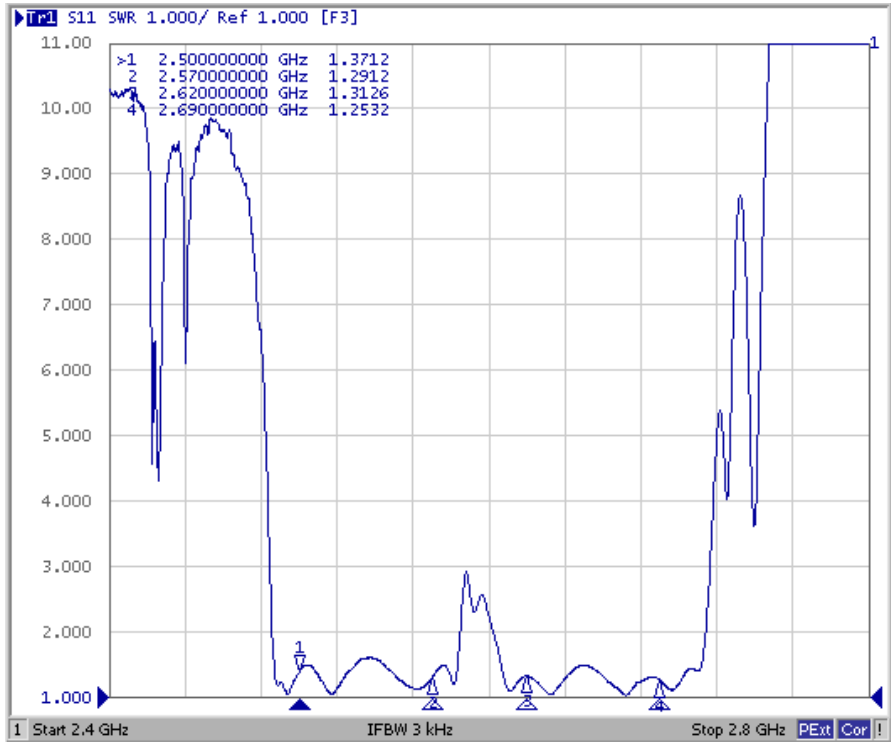

Tx to Ant (Wide span)

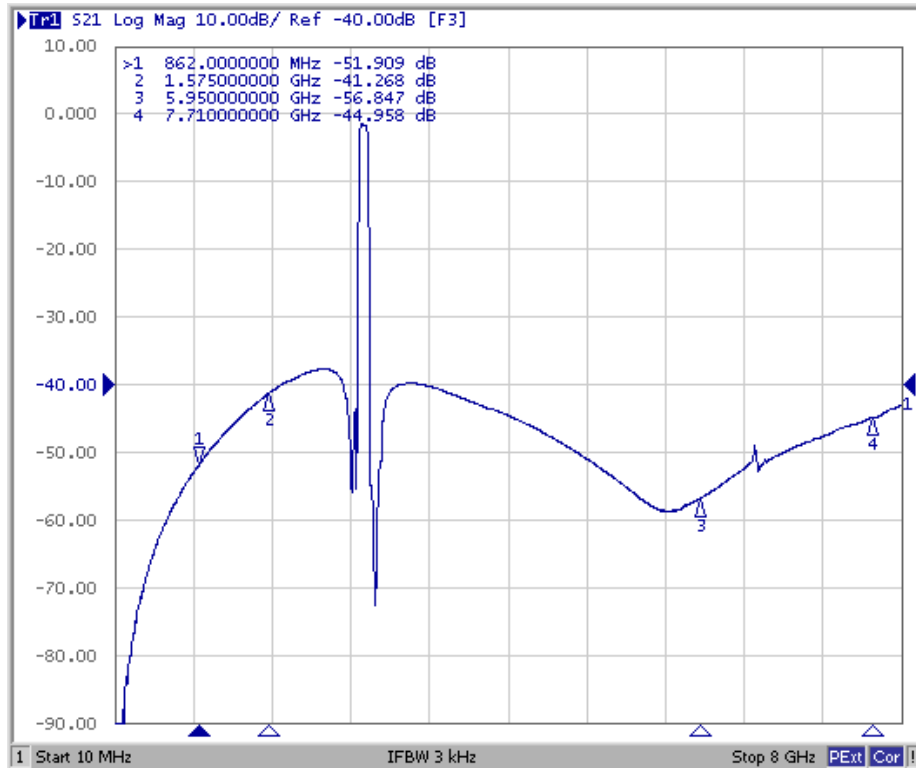

Ant to Rx (Wide span)

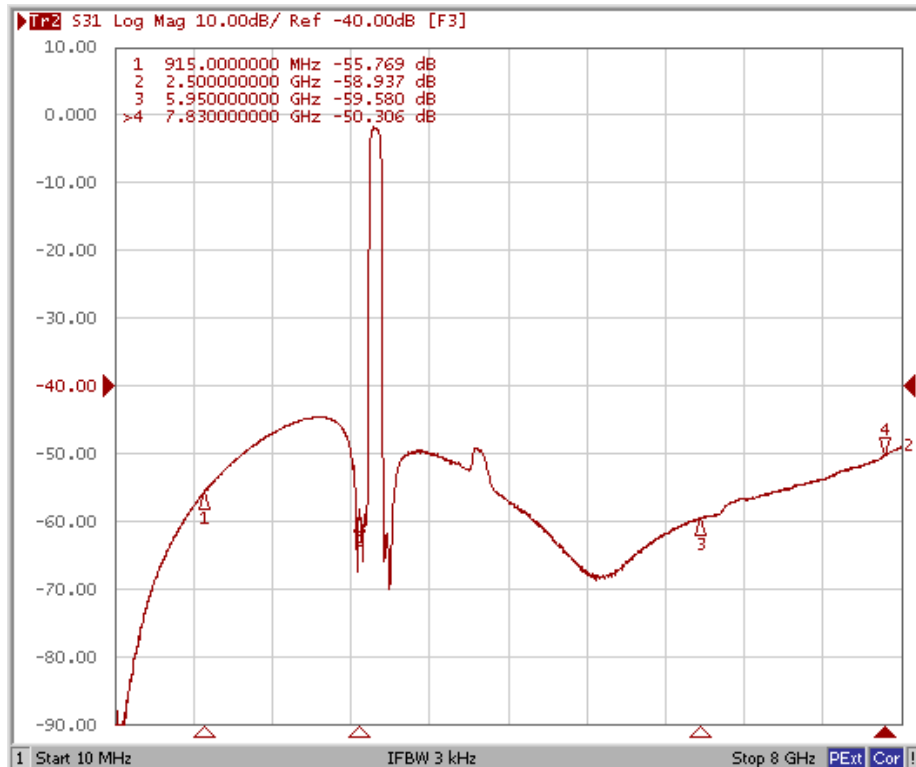

Tx to Rx Isolation (Wide span)

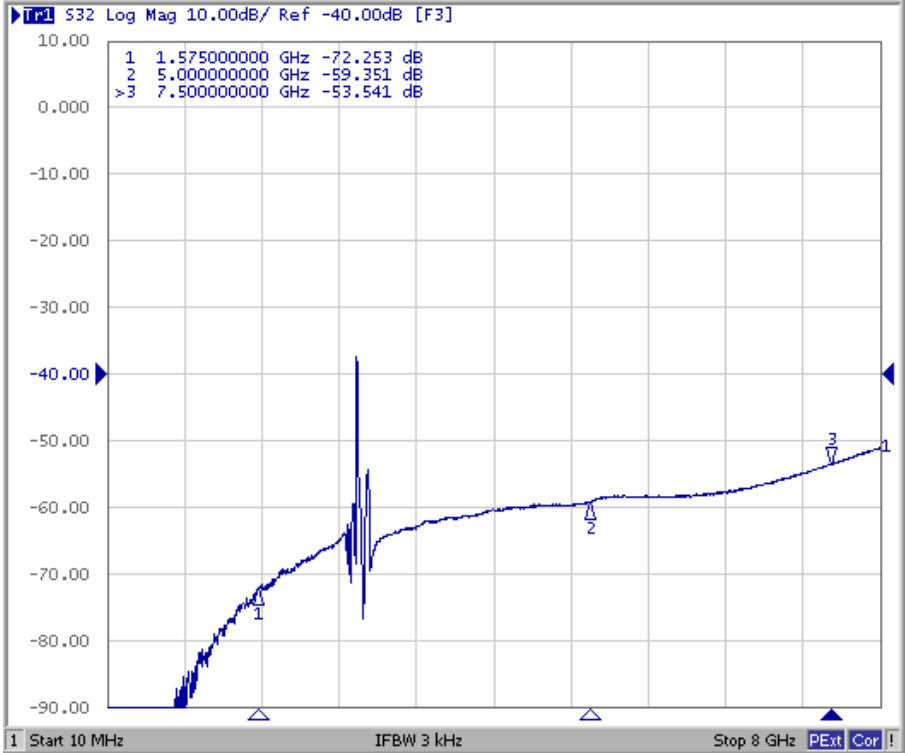

F.OUTLINE DRAWIN: (Mass Production)

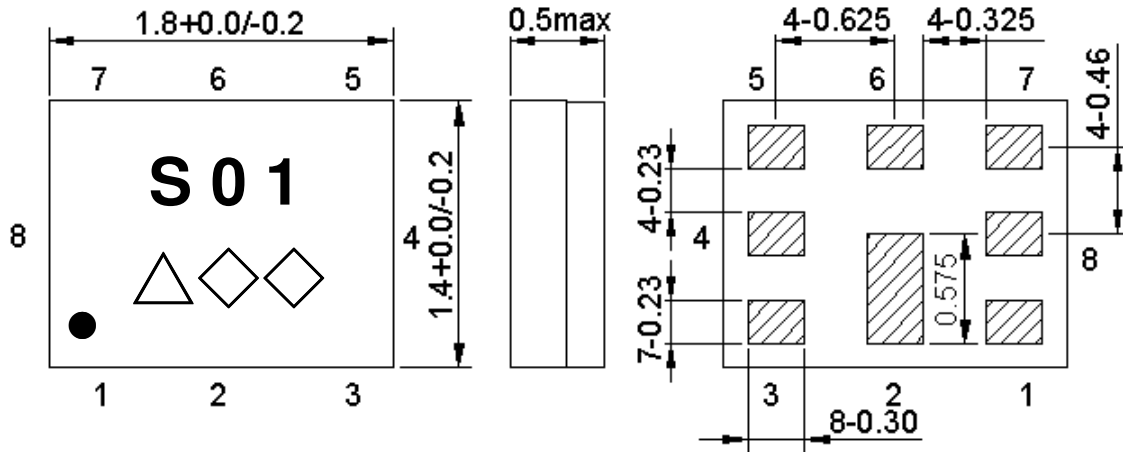

Marking name : **S01**

△: Date code(2016 May → s ,....., 2019 Dec→m.)

◇◇: Lot Code.

Product Date Code. Follow below table.

Year	Jan	Feb	Mar	Apr	May	Jun	Jul	Aug	Sep	Oct	Nov	Dec
2016	n	p	q	r	s	t	u	v	w	x	y	z
2017	A	B	C	D	E	F	G	H	J	K	L	M
2018	N	P	Q	R	S	T	U	V	W	X	Y	Z
2019	a	b	c	d	e	f	g	h	j	k	l	m

Pin Configuration

Pin No.	Pin name	Description
1	Rx	Receiver Pin
2	GND	Ground Pin
3	Tx	Transmitter Pin
4	GND	Ground Pin
5	GND	Ground Pin
6	ANT	Antenna Pin
7	GND	Ground Pin
8	GND	Ground Pin

Figure 1. Dimensions and Pin assignment

Top View (Sample Production):

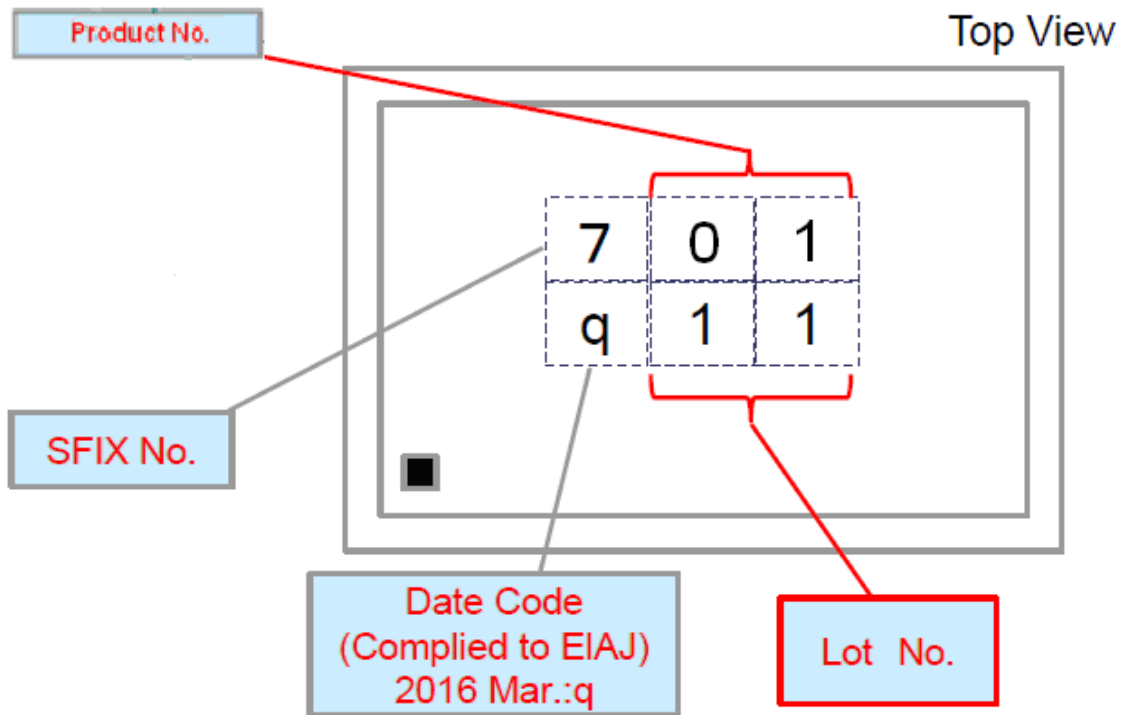

Lot No. is indicated by Arabic numerals 0 to 9 or characters A to Z and a to z (However, except I, O, l, l and o).

G. PACKING:

1. REEL DIMENSION

(Please refer to FR-75D10 for packing quantity)

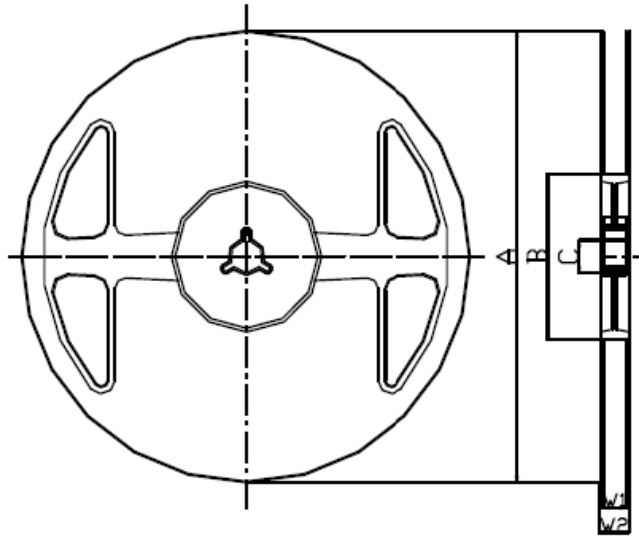

Materials of Reel

Material : Polystyrene + Carbon

Characteristics : Conforms to EIAJ-ET-7200A

Color : Black

Surface resistance (reference value) : $10^9\Omega/\text{sq Max.}$

Unit : mm

Code	Quantity	A	B	C	W1	W2
Z	3,000 pcs	$\phi 180.0 +0.0/-1.5$	$\phi 66.0 +/-0.5$	$\phi 13.0 +/-0.2$	$9.0 +1.0/-0.0$	$11.4 +/-1.0$

2. TAPE DIMENSION

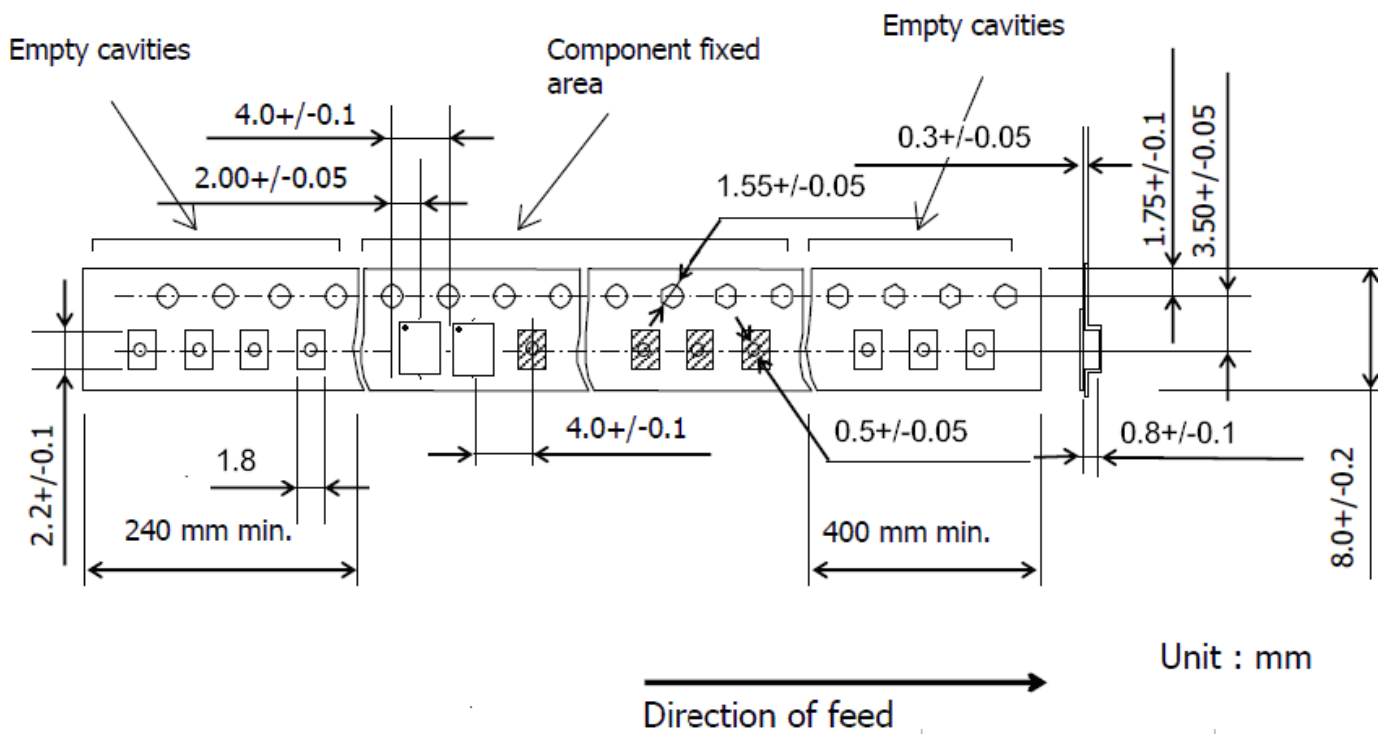

Unit : mm

H. RECOMMENDED REFLOW PROFILE :

1. Preheating shall be fixed at 150~180°C for 60~90 seconds.
2. Ascending time to preheating temperature 150°C shall be 30 seconds min.
3. Heating shall be fixed at 220°C for 50~80 seconds and at 245~260°C peak (min. 10sec).
4. Time : 2 times.

