



# TAI-SAW TECHNOLOGY CO., LTD.

No. 3, Industrial 2nd Rd., Ping-Chen Industrial District,  
Taoyuan, 324, Taiwan, R.O.C.

TEL: 886-3-4690038 FAX: 886-3-4697532

E-mail: [tstsales@mail.taisaw.com](mailto:tstsales@mail.taisaw.com) Web: [www.taisaw.com](http://www.taisaw.com)

## Product Specifications Approval Sheet

Product Name: SAW DPX 1747.5/1842.5MHz LTE Band3 SMD1.8X1.4 mm

TST Parts No.: TF0135B (This part is compliant with AEC-Q200)

Customer Part No.: \_\_\_\_\_

Customer signature required
Company: _____
Division: _____
Approved by : _____
Date: _____

Checked by: \_\_\_\_\_ Anne Chen *Anne Chen*

Approved by: \_\_\_\_\_ Andy Yu *Andy Yu*

Date: \_\_\_\_\_ 2020/02/14

1. Customer signed back is required before TST can proceed with sample build and receive orders.
2. Orders received without customer signed back will be regarded as agreement on the specifications.
3. Any specifications changes must be approved upon by both parties and a new revision of specifications shall be released to reflect the change



# TAI-SAW TECHNOLOGY CO., LTD.

No. 3, Industrial 2nd Rd., Ping-Chen Industrial District,  
Taoyuan, 324, Taiwan, R.O.C.

TEL: 886-3-4690038 FAX: 886-3-4697532

E-mail: [tstsales@mail.taisaw.com](mailto:tstsales@mail.taisaw.com) Web: [www.taisaw.com](http://www.taisaw.com)

SAW DPX 1747.5/1842.5MHz 74.7/74.7MHz BW Single type SMD 1.8X1.4 mm  
MODEL NO.: TF0135B REV. No.: 2.0

## A. MAXIMUM RATING:

1. Input power : 29dBm (Ta=+50deg C,5000h,CW )
2. Maximum DC Voltage: +/-3 V
3. Operating temperature range: -40 °C to +85 °C
4. Storage temperature range: -40 °C to +85 °C
5. Moisture Sensitivity Level: Level 1 (MSL 1)
6. ESD 50V(MM) 150V(HBM)
7. Pre-aging condition to 150C/8hrs

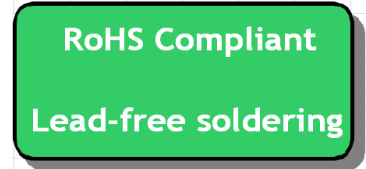

Electrostatic Sensitive Device (ESD)

## B. ELECTRICAL CHARACTERISTICS:

Terminating impedance (Tx Port): 50//10nH Ω

Terminating impedance (Rx Port): 50//12nH Ω

Terminating impedance (Ant Port): 50//4.3nH Ω

### Tx to ANT

Parameters Description		Unit	Minimum	Typical	Maximum	Note
Insertion Loss	1710.15~ 1784.85 MHz	dB(*1)	-	2.3	3.0	-20~65°C
					3.3	-65~85°C
Ripple(any 5MHz)	1710.15~ 1784.85 MHz	dB	-	1.6	2.8	
VSWR	ANT	-	-	1.4	2.0	
	Tx	-	-	1.4	2.0	
<b>Attenuation:</b>						
1559 ~1586 MHz		dB	36	44	-	Compass, GPS
1597 ~1606 MHz		dB	33	43	-	GLONASS-
1805 ~1880 MHz		dB	40	52	-	Rx
2400 ~2500 MHz		dB	33	39	-	ISM
3420 ~3570 MHz		dB	25	32	-	2f0
5130 ~5355 MHz		dB	20	40	-	3f0

### ANT to Rx

Parameters Description		Unit	Minimum	Typical	Maximum	Note
Insertion Loss	1805.15~ 1879.85 MHz	dB(*1)	-	2.1	2.9	0~85°C
					3.3	-20~0°C
Ripple	1805.15~ 1879.85 MHz	dB	-	1.4	2.8	
VSWR	ANT	-	-	1.6	2.3	
	Rx	-	-	1.5	2.2	
<b>Attenuation:</b>						
1710 ~ 1785 MHz		dB	50	54	-	Tx
2400 ~ 2500 MHz		dB	42	45	-	ISM
3610 ~ 3760 MHz		dB	47	57		2f0
5415 ~ 5640 MHz		dB	42	49		3f0

### Tx to Rx

Isolation	1710.15 ~ 1784.85 MHz	dB	50	56	-	Tx
	1805.15 ~ 1879.85 MHz	dB	46		-	Rx -20~0°C
		dB	50	56		Rx +0~ +85°C

(\*1) Specification of insertion loss excludes loss that comes from the test board.

### C. Frequency Characteristics:

## Tx to Ant

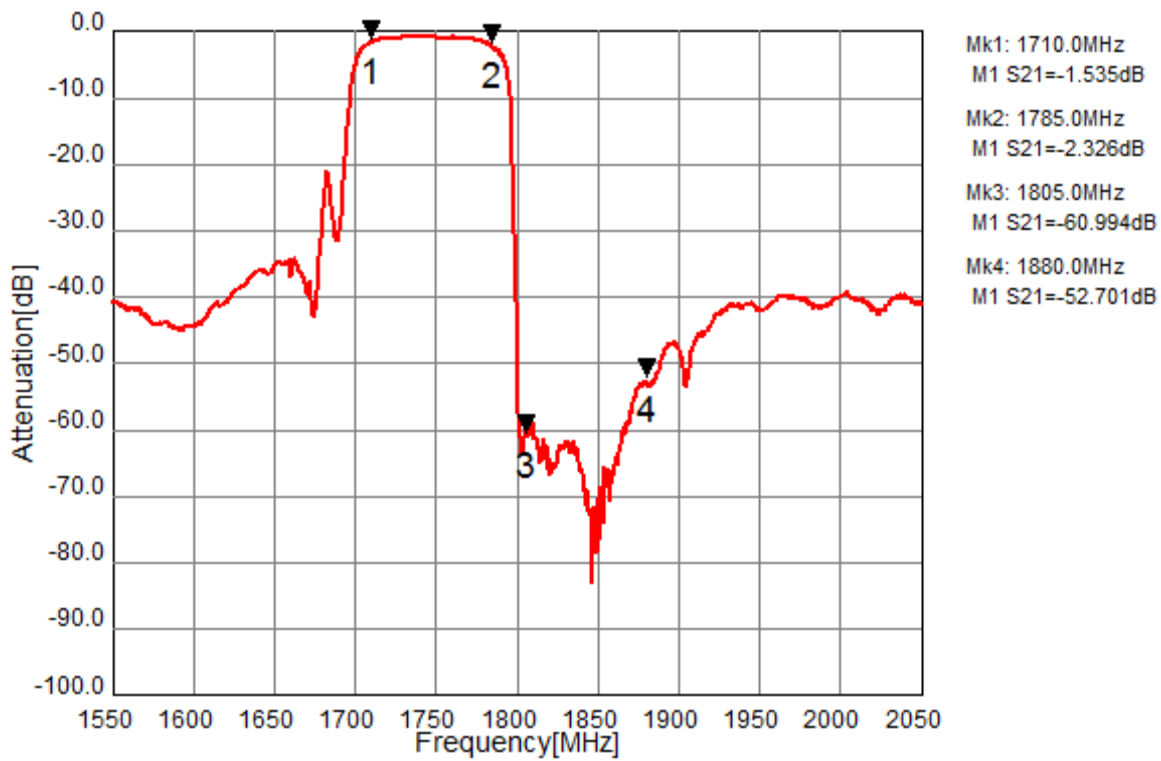

## Ant to Rx

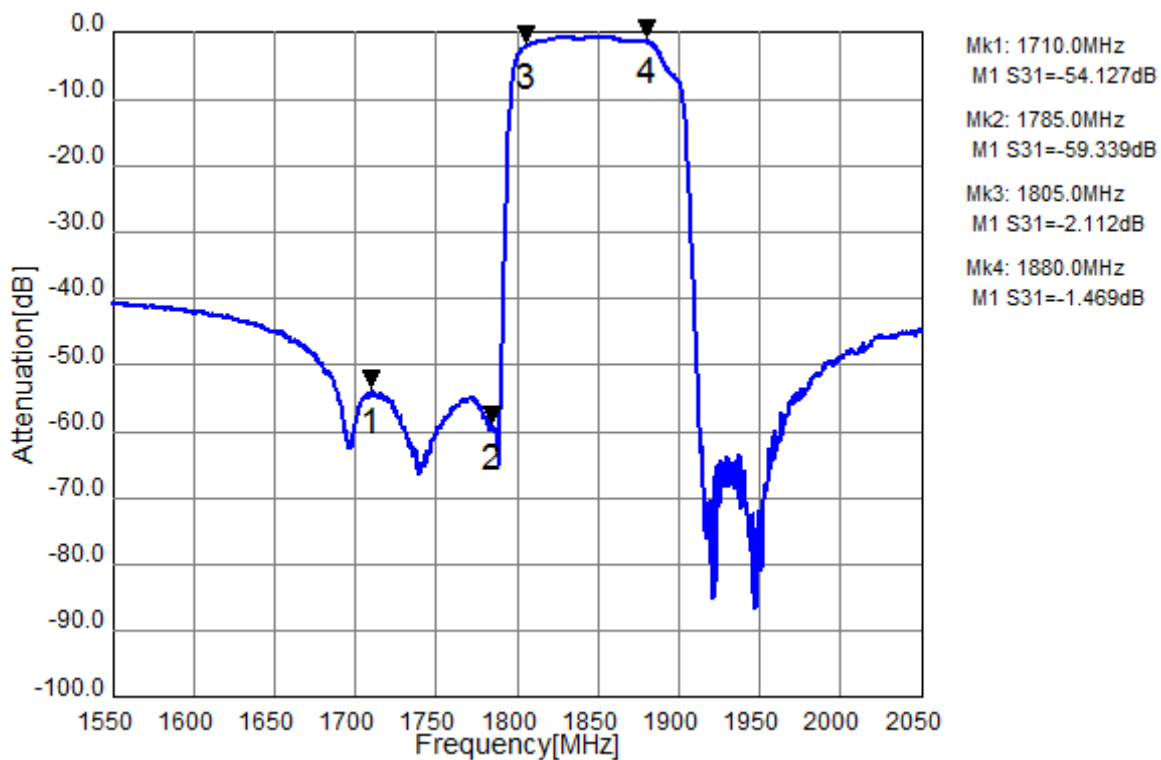

## Tx to Ant, Ant to Rx

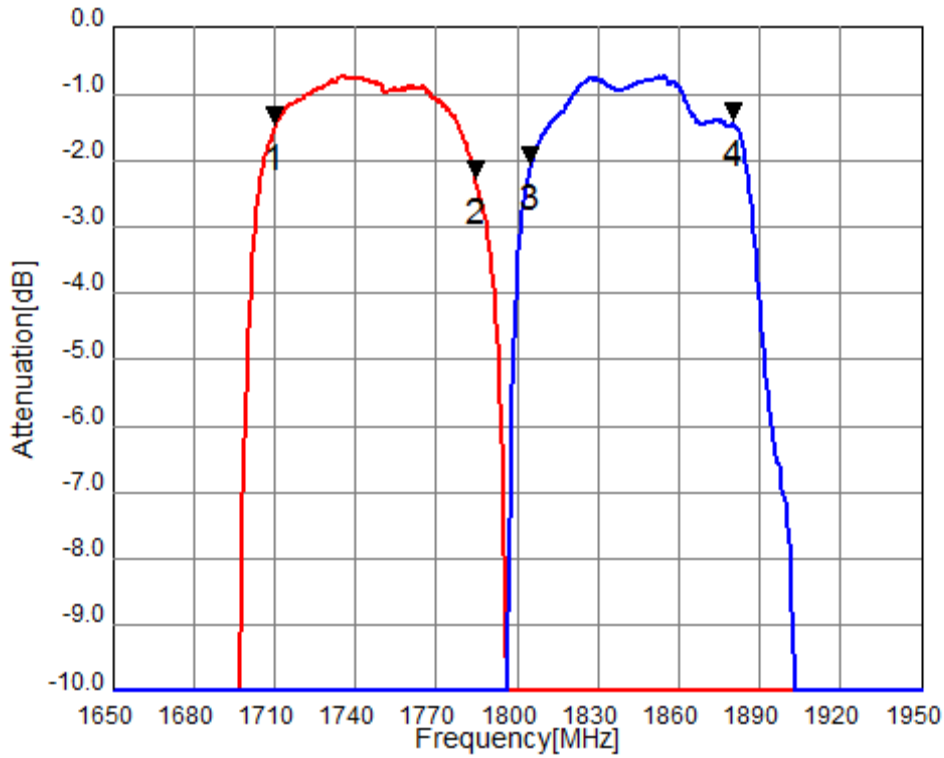

## Tx to Rx Isolation

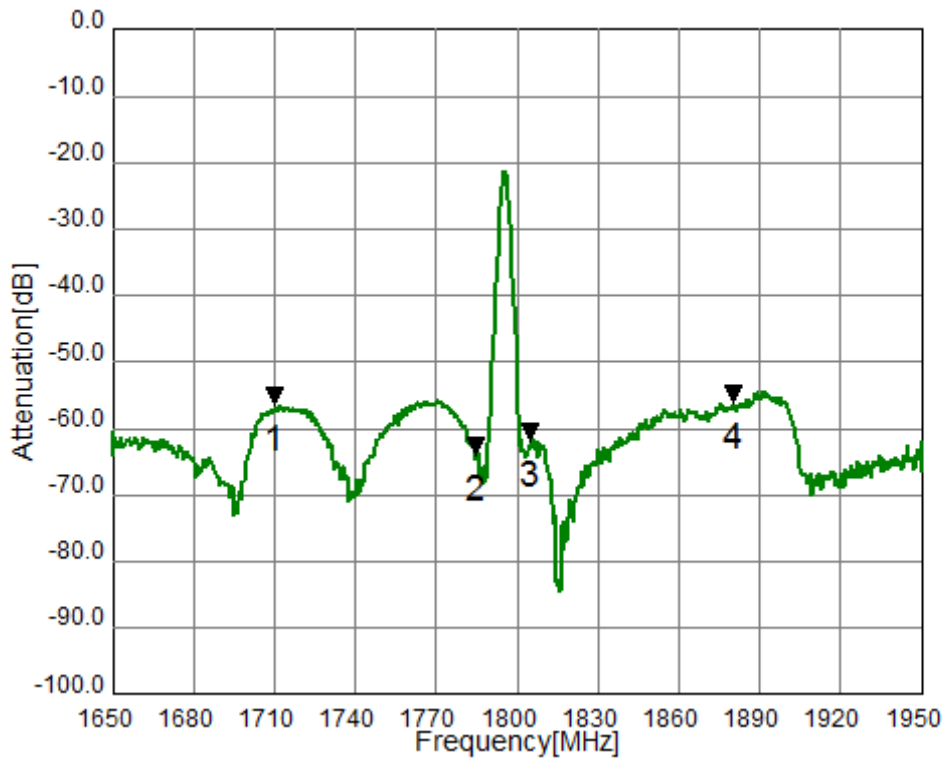

# Tx Port

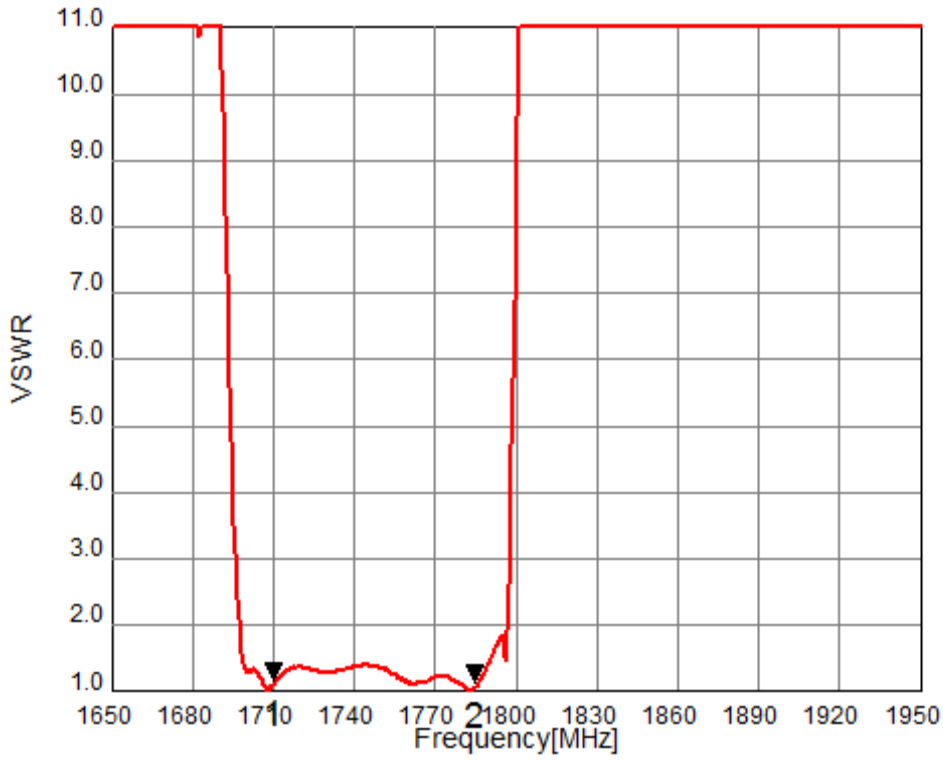

Mk1: 1710.0MHz  
M1 VS2= 1.119  
Mk2: 1785.0MHz  
M1 VS2= 1.064

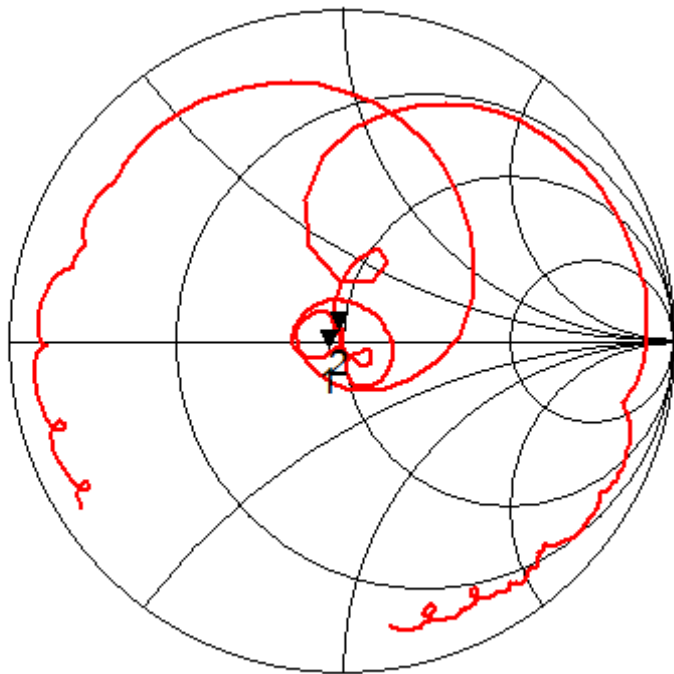

Mk1: 1710.0MHz  
S22= 0.915 - j 0.066  
Mk2: 1785.0MHz  
S22= 0.973 + j 0.055

# Rx Port

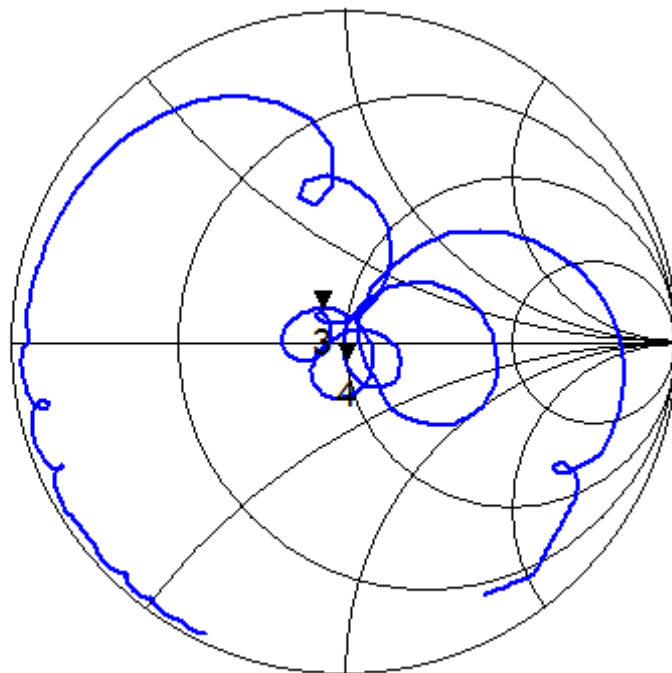
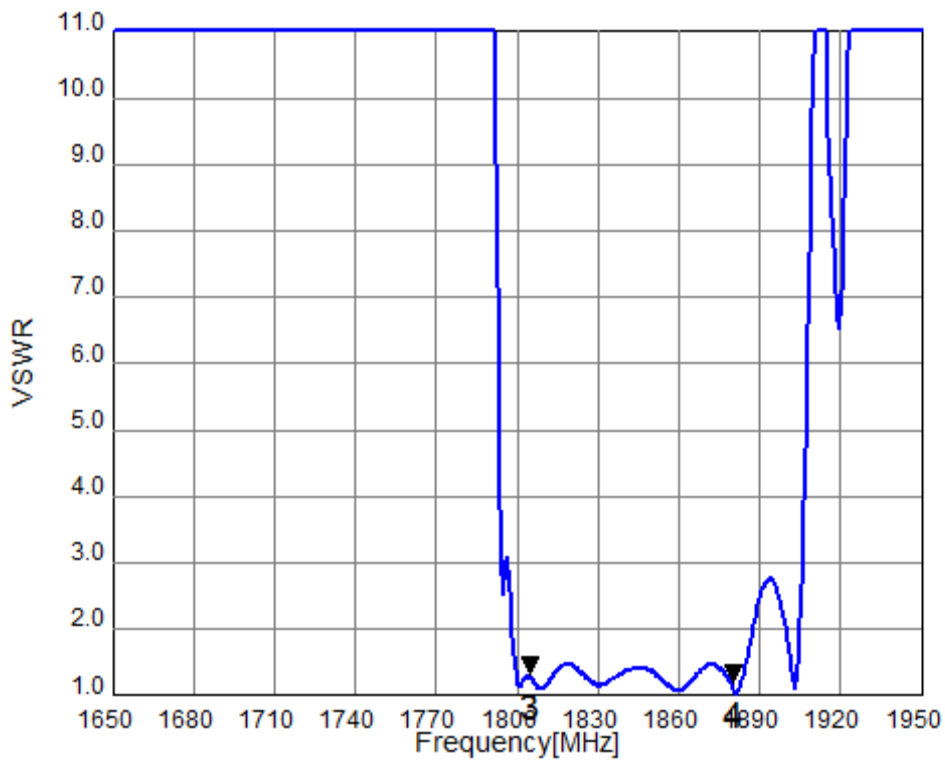

# Ant Port

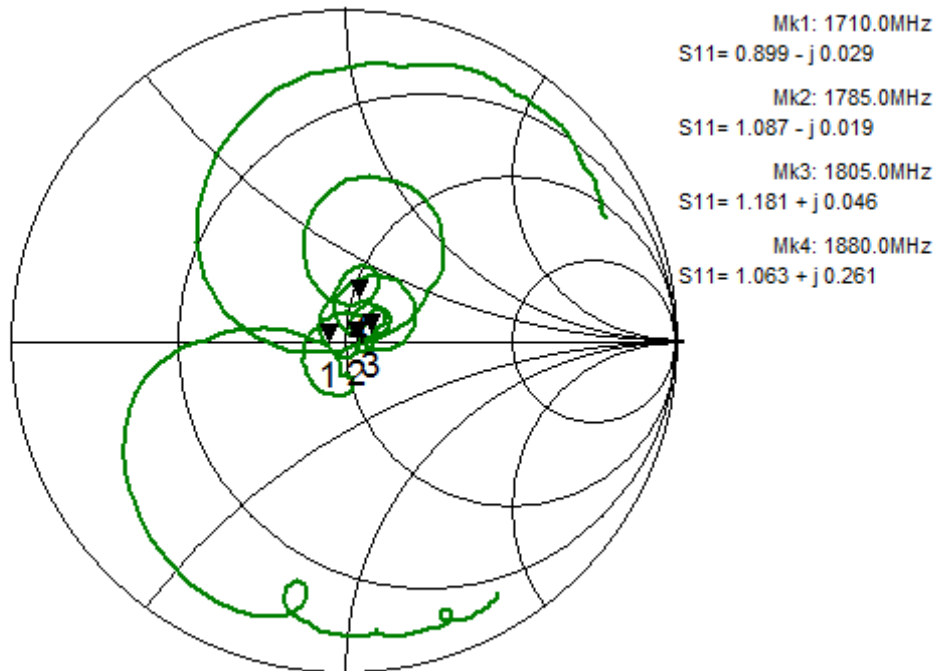
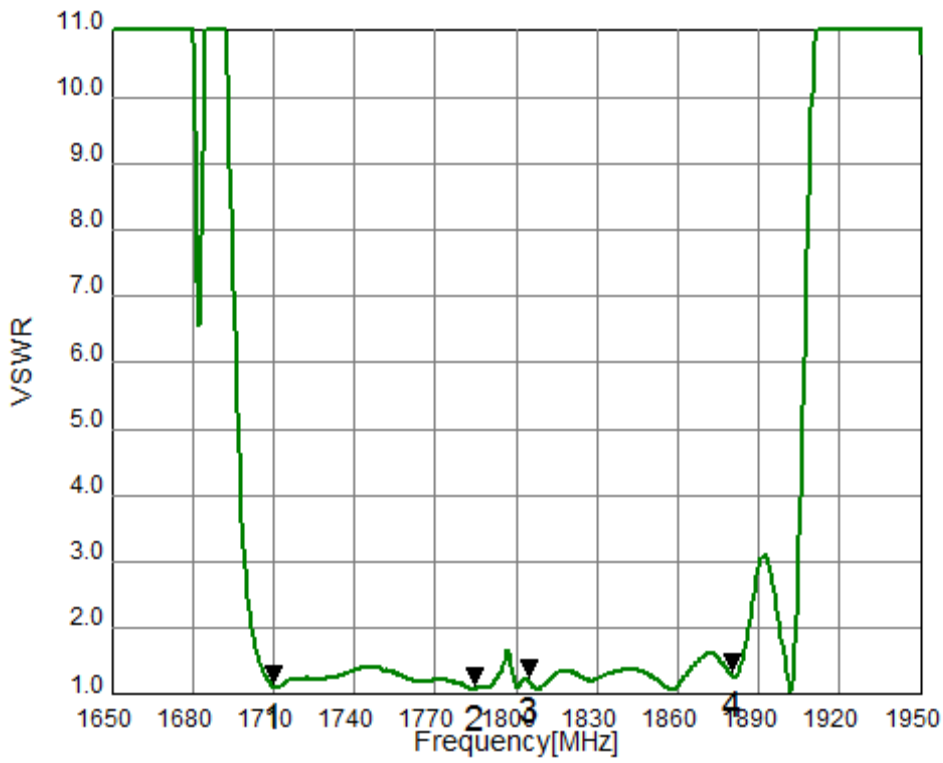



## Tx to Ant (Wide span)

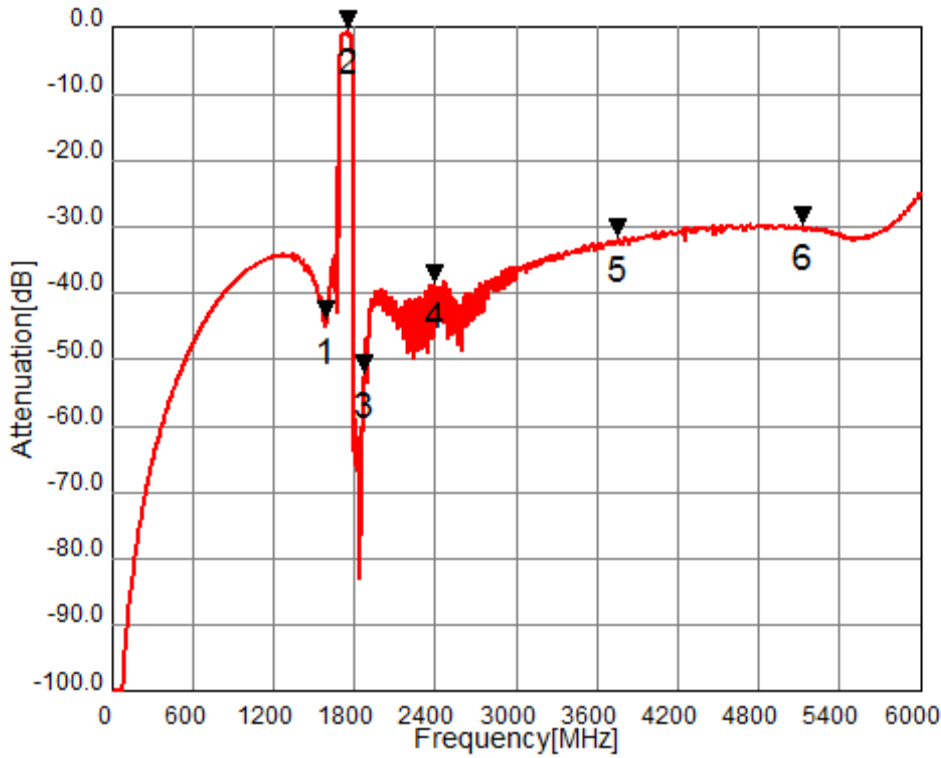

## Ant to Rx (Wide span)

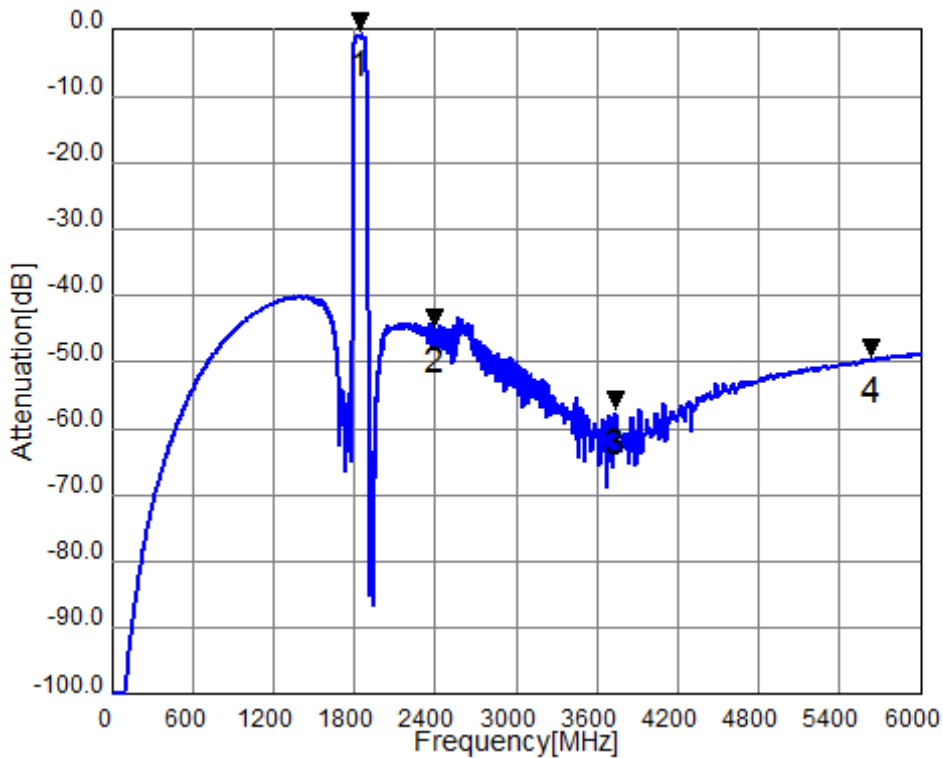

# Tx to Rx Isolation(Wide span)

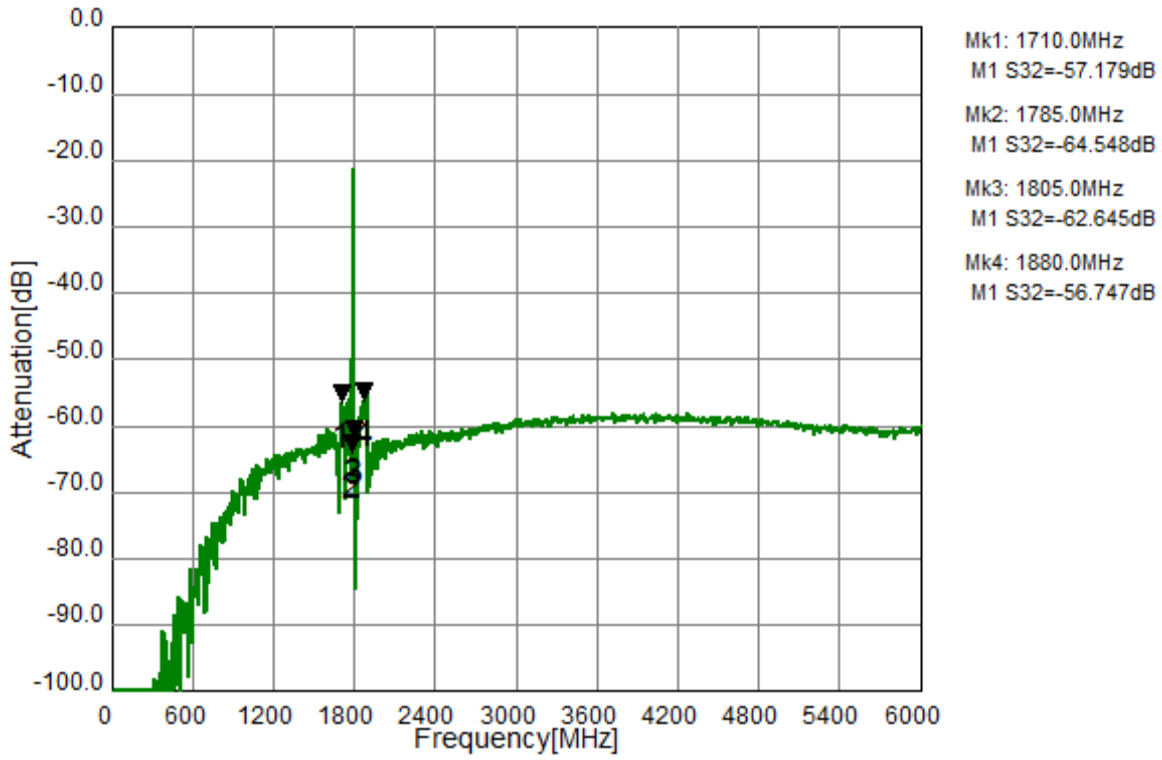

**D. MEASUREMENT CIRCUIT:**

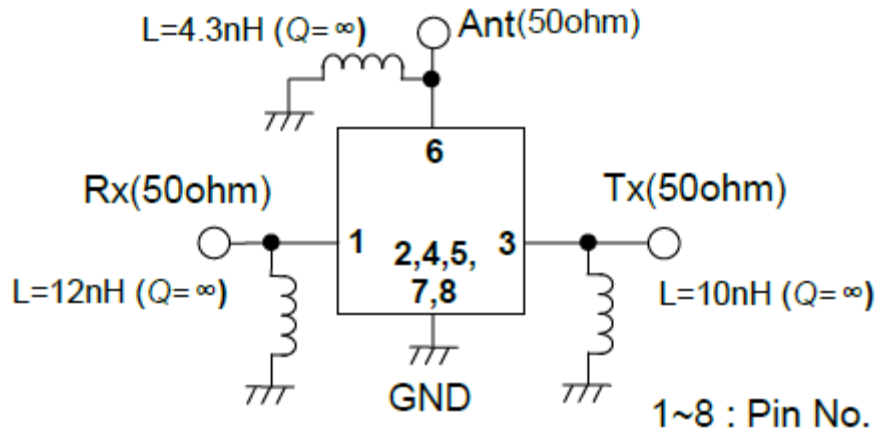

**Recommended foot print pattern**

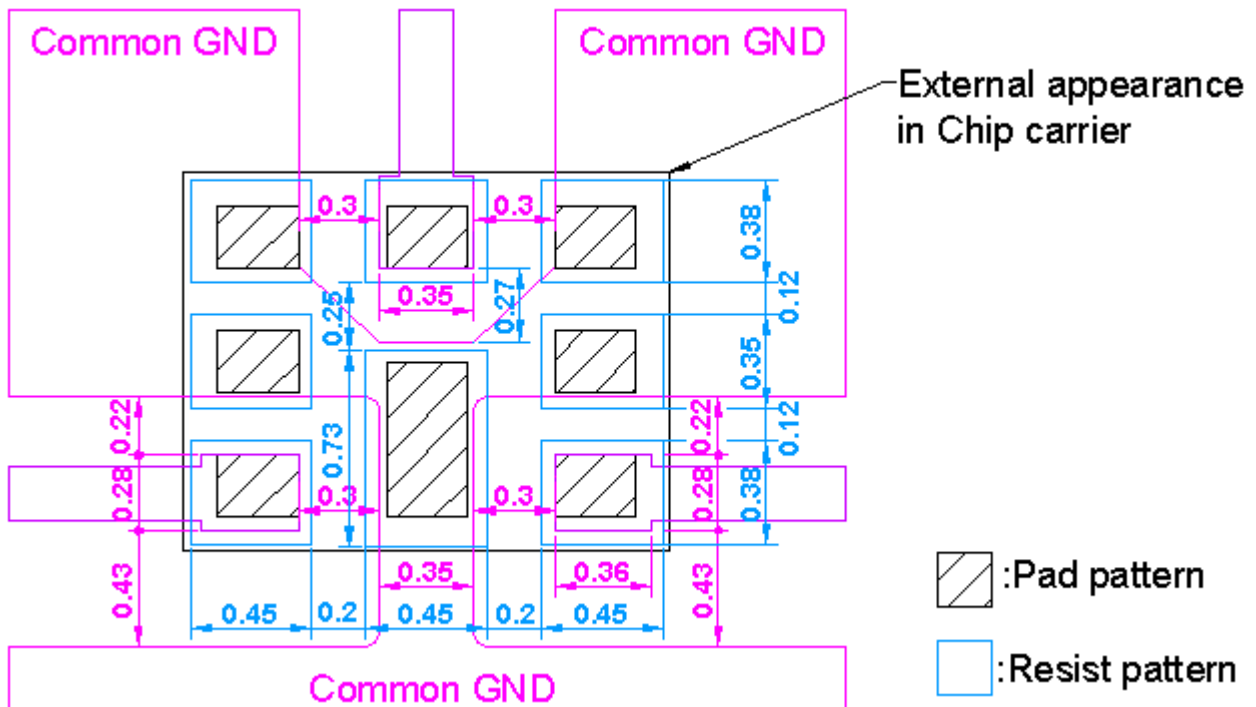

**E. OUTLINE DRAWING: (Mass Production)**

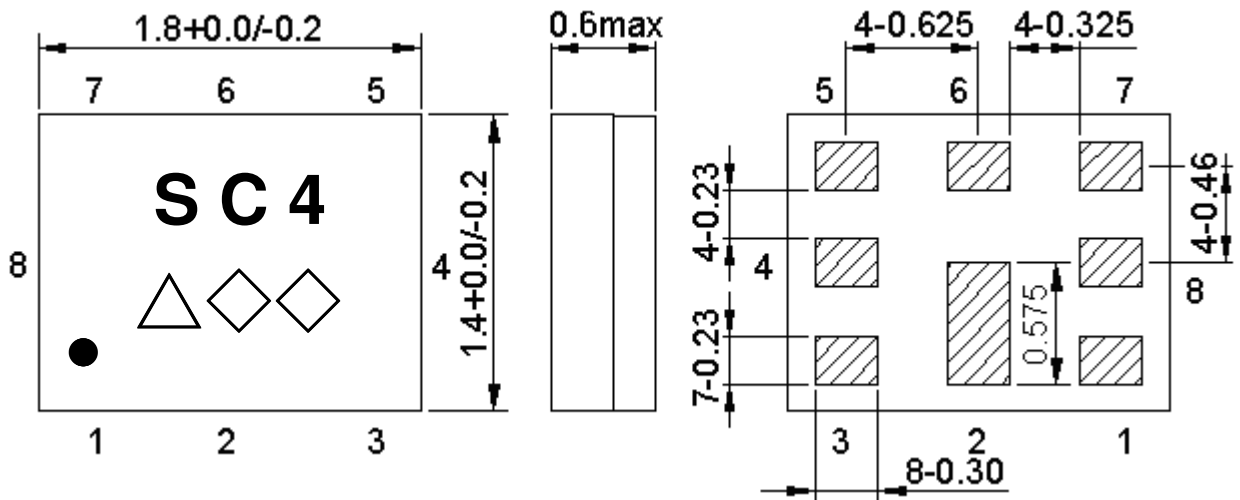

Marking name : C4

△: Date code ( 2016 May → s ,....., 2019 Dec→m.)

◇◇: Lot Code.

Product Date Code. Follow below table.

Year	Jan	Feb	Mar	Apr	May	Jun	Jul	Aug	Sep	Oct	Nov	Dec
2016	n	p	q	r	s	t	u	v	w	x	y	z
2017	A	B	C	D	E	F	G	H	J	K	L	M
2018	N	P	Q	R	S	T	U	V	W	X	Y	Z
2019	a	b	c	d	e	f	g	h	j	k	l	m

**Pin assignment**

Pin No.	Pin name	Description
1	Rx	Receiver
2	GND	Ground
3	Tx	Transmitter
4	GND	Ground
5	GND	Ground
6	ANT	Antenna
7	GND	Ground
8	GND	Ground

**Top View (Sample Production):**

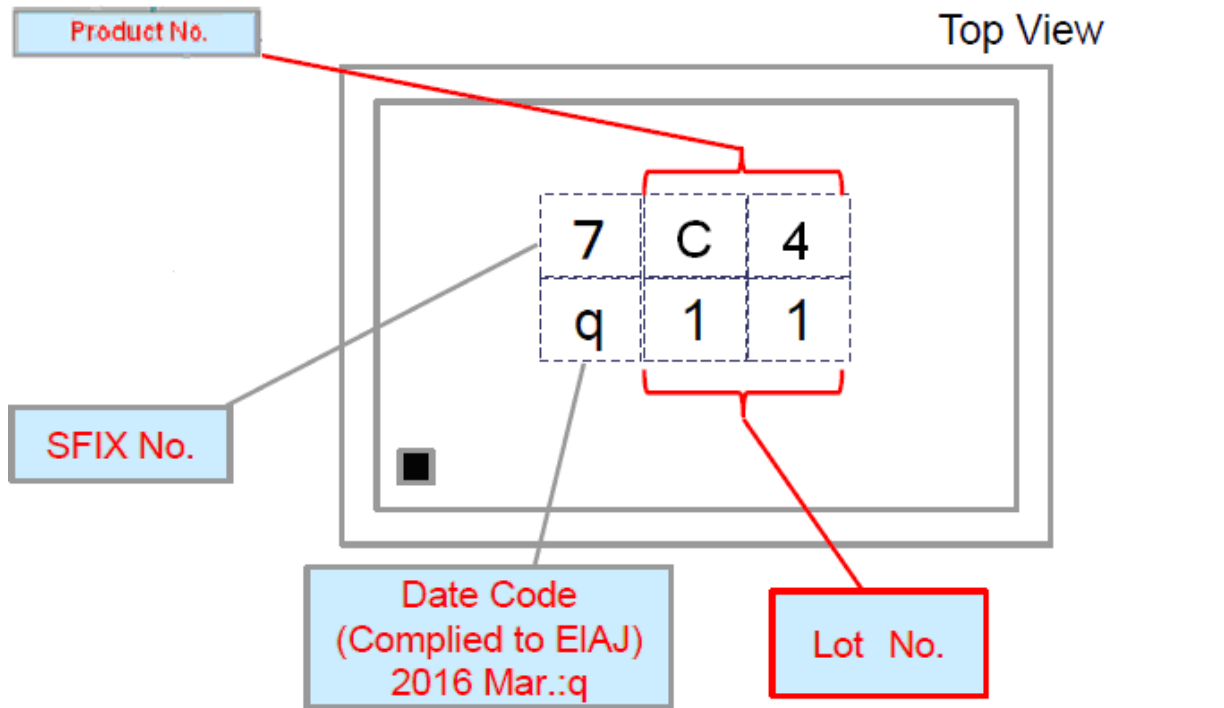

Lot No. is indicated by Arabic numerals 0 to 9 or characters A to Z and a to z (However, except I, O, l, I and o).

## F. PACKING:

### 1. REEL DIMENSION

(Please refer to FR-75D10 for packing quantity)

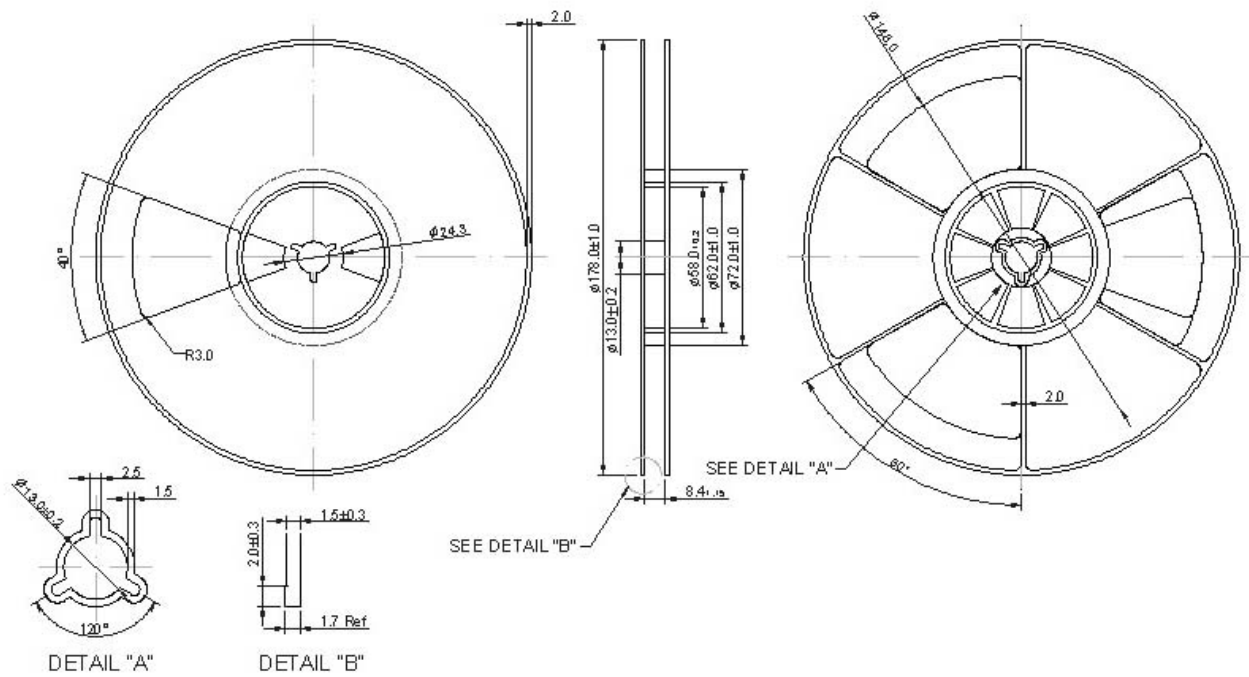

### 2. TAPE DIMENSION

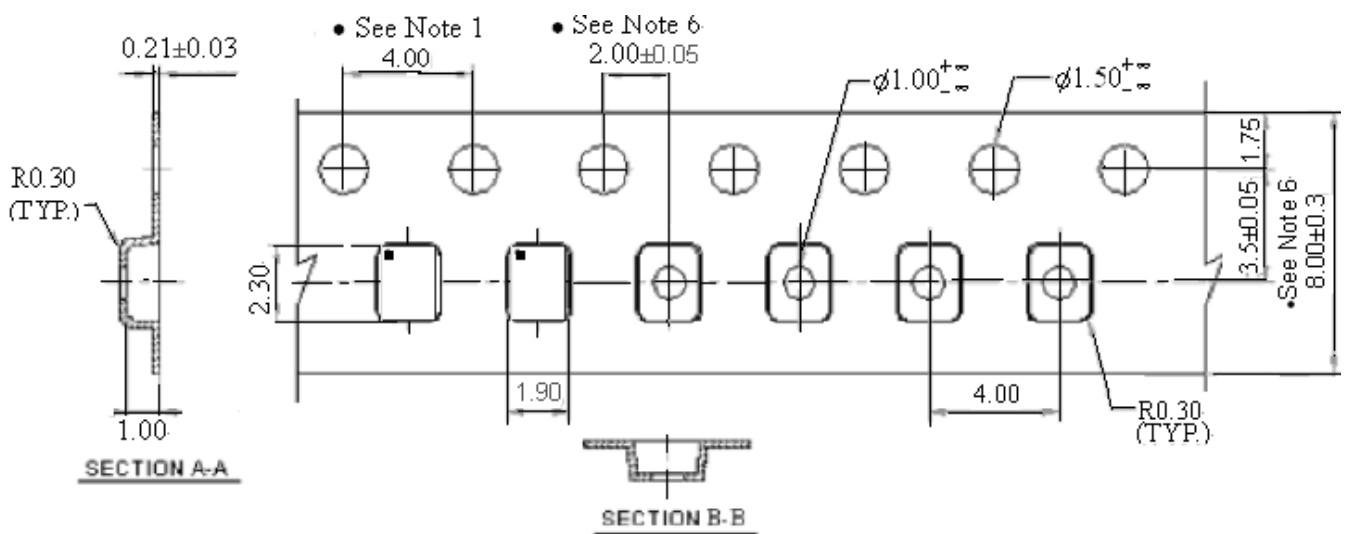

## G. RECOMMENDED REFLOW PROFILE:

1. Preheating shall be fixed at 150~180°C for 60~90 seconds.
2. Ascending time to preheating temperature 150°C shall be 30 seconds min.
3. Heating shall be fixed at 220°C for 50~80 seconds and at 260°C +0/-5°C peak (20~40sec).
4. Time: 3 times.

