



TAI-SAW TECHNOLOGY CO., LTD.

No. 3, Industrial 2nd Rd., Ping-Chen Industrial District,
Taoyuan, 324, Taiwan, R.O.C.

TEL: 886-3-4690038 FAX: 886-3-4697532

E-mail: tstsales@mail.taisaw.com Web: www.taisaw.com

Product Specifications Approval Sheet

Product Name: BAW DPX 1882.5/1962.5MHz 65/64.04MHz BW Band25 SMD1.8X1.4 mm

TST Parts No.: TF0136A

Customer Part No.: _____

Customer signature required
Company: _____
Division: _____
Approved by : _____
Date: _____

Checked by: _____ Anne Chen 

Approved by: _____ Bob Chau 

Date: _____ 1/23/2018

1. Customer signed back is required before TST can proceed with sample build and receive orders.
2. Orders received without customer signed back will be regarded as agreement on the specifications.
3. Any specifications changes must be approved upon by both parties and a new revision of specifications shall be released to reflect the change



TAI-SAW TECHNOLOGY CO., LTD.

No. 3, Industrial 2nd Rd., Ping-Chen Industrial District,
Taoyuan, 324, Taiwan, R.O.C.

TEL: 886-3-4690038 FAX: 886-3-4697532

E-mail: tstsales@mail.taisaw.com Web: www.taisaw.com

BAW DPX 1882.5/1962.5MHz 65/64.04MHz BW Single type SMD 1.8X1.4 mm
MODEL NO.: TF0136A REV. No.: 3.0

A. MAXIMUM RATING:

1. Input power : 29dBm (Ta=+50deg C,50000h,CW)
2. Maximum DC Voltage: +/-3 V
3. Operating temperature range: -10 °C to +85 °C
4. Storage temperature range: -10 °C to +85 °C
5. Moisture Sensitivity Level: Level 1 (MSL 1)
6. ESD 50V(MM) 150V(HBM)

RoHS Compliant
Lead free
Lead-free soldering

Electrostatic Sensitive Device (ESD)

B. ELECTRICAL CHARACTERISTICS:

Terminating impedance(Tx Port): 50 Ω (Single-ended)

Terminating impedance(Rx Port): 50 Ω (Single-ended)

Terminating impedance(Ant Port): 50//3.9nH Ω (Single-ended)

Tx to ANT

Parameters Description		Unit	Minimum	Typical	Maximum	Note
Insertion Loss	1850~ 1915 MHz	dB(*1)	-	2.4	3.8	
	1850.48~ 1909.52 MHz			1.9	2.7	(*2)
	1850.625~1909.375 MHz			2.0	3.0	(*3)
Ripple(any 5MHz)	1850 ~ 1915 MHz	dB	-	0.5	2.4	
VSWR	ANT	-	-	1.6	2.1	
	Tx	-	-	1.6	2.2	

Attenuation:

1559 ~1563 MHz	dB	31	34	-	-
1565.4 ~ 1573.4 MHz	dB	31	34	-	-
1573.4 ~ 1577.5 MHz	dB	31	34	-	-
1577.5 ~ 1585.4 MHz	dB	31	34	-	-
1597.6 ~ 1605.9 MHz	dB	31	34	-	-
1930 ~ 1995 MHz	dB	35	50	-	-10~25°C
1930 ~ 1995 MHz	dB	45	50	-	+25~85°C
2400 ~ 2500 MHz	dB	22	36		
3700 ~ 3830 MHz	dB	28	38		
5550 ~ 5745 MHz	dB	20	30		

ANT to Rx

Parameters Description		Unit	Minimum	Typical	Maximum	Note
Insertion Loss	1930.48 ~ 1994.52 MHz	dB(*1)	-	2.7	3.8	-10~25°C
					3.6	+25~85°C
Ripple(any 5MHz)	1930.48 ~ 1994.52 MHz	dB	-	0.8	2.5	
VSWR	ANT	-	-	1.7	2.2	
	Rx	-	-	1.8	2.3	
Attenuation:						
1850 ~ 1915 MHz		dB	40	57	-	-
2400 ~ 2500 MHz		dB	40	49	-	-
3860 ~ 3990 MHz		dB	40	63		
5790 ~ 5985 MHz		dB	40	65		

Tx to Rx

Isolation	1850.25 ~ 1914.75 MHz	dB	53	57	-	-10~60°C-
		dB	50	57	-	+60~85°C
	1930.25 ~ 1994.75 MHz	dB	45	52	-	(*3) -10~25°C
		dB	48	52		(*3)+25~85°C

(*1) Specification of insertion loss excludes loss that comes from the test board.

(*2) The integrated isolation over channel band width (+/- 1.92MHz)

(*3) The integrated isolation over channel band width (+/- 0.625MHz)

C. Frequency Characteristics:

Tx to Ant

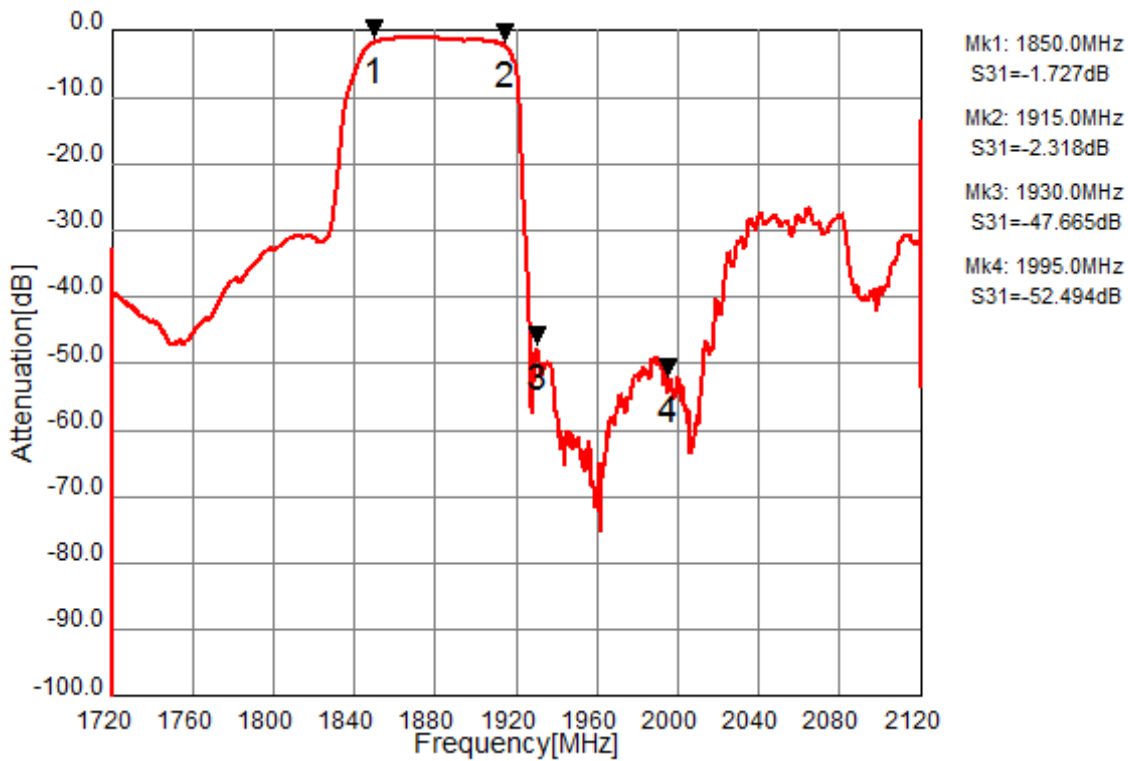

Ant to Rx

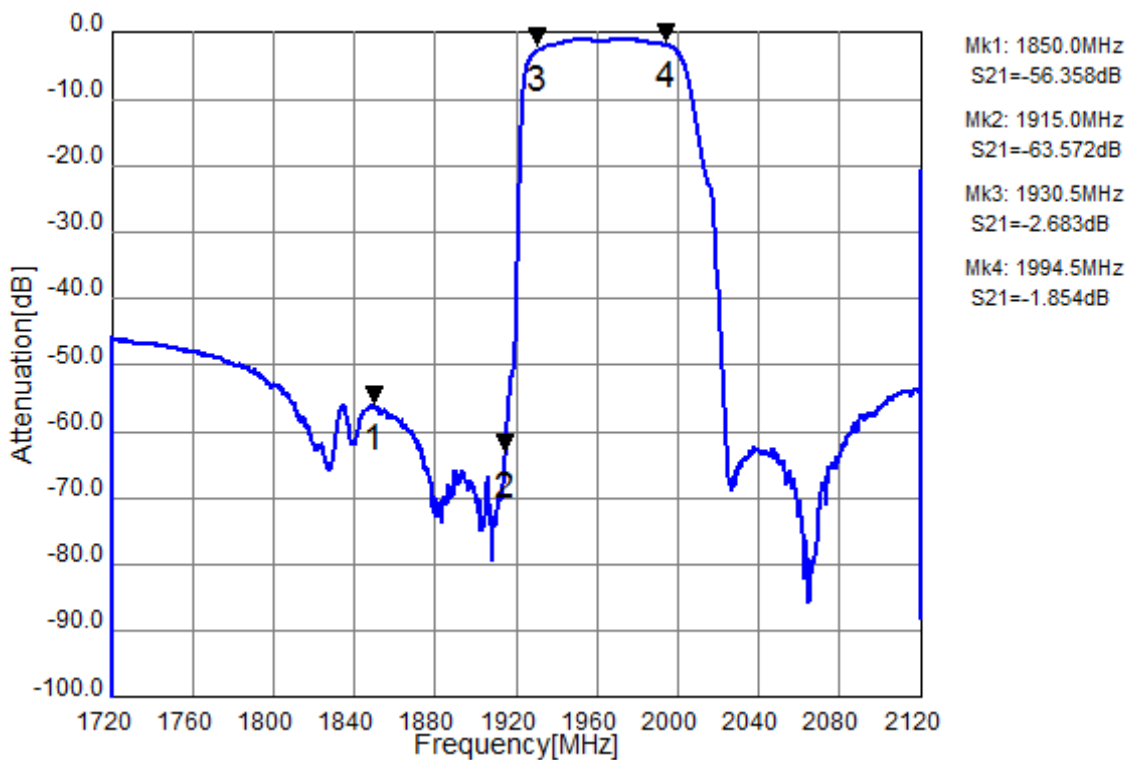

Tx to Ant, Ant to Rx

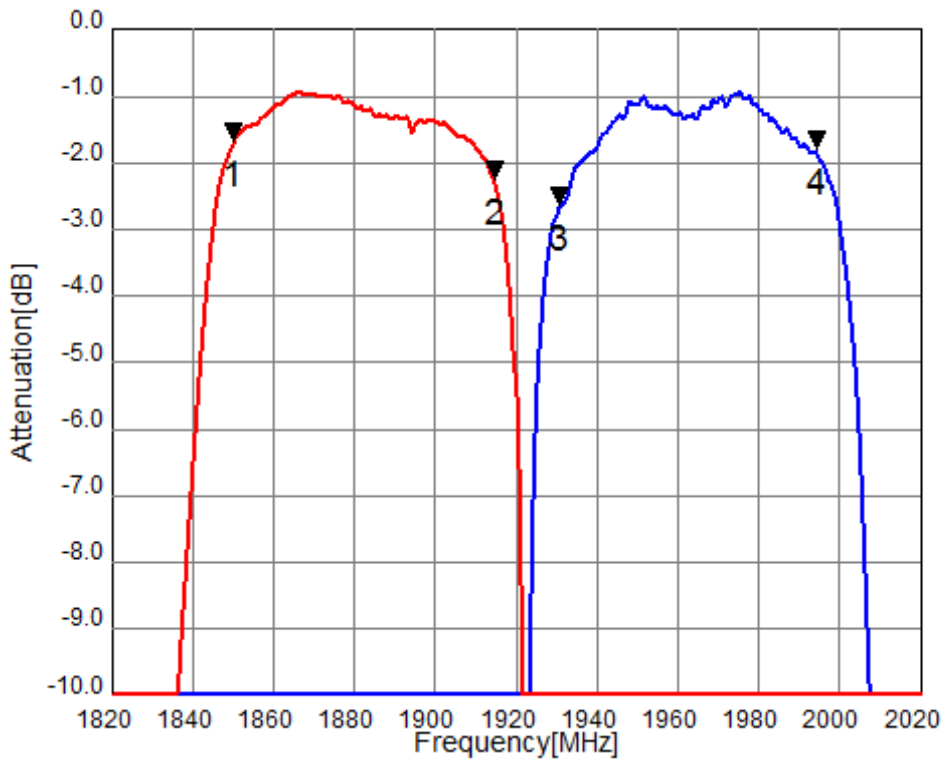

Tx to Rx Isolation

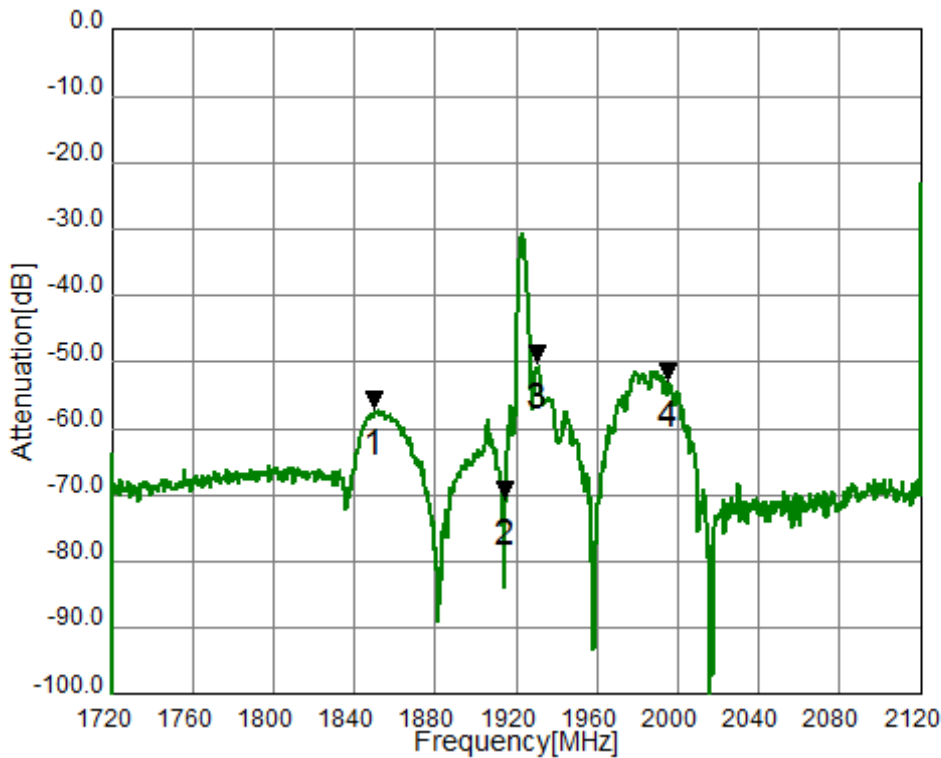

Tx Port

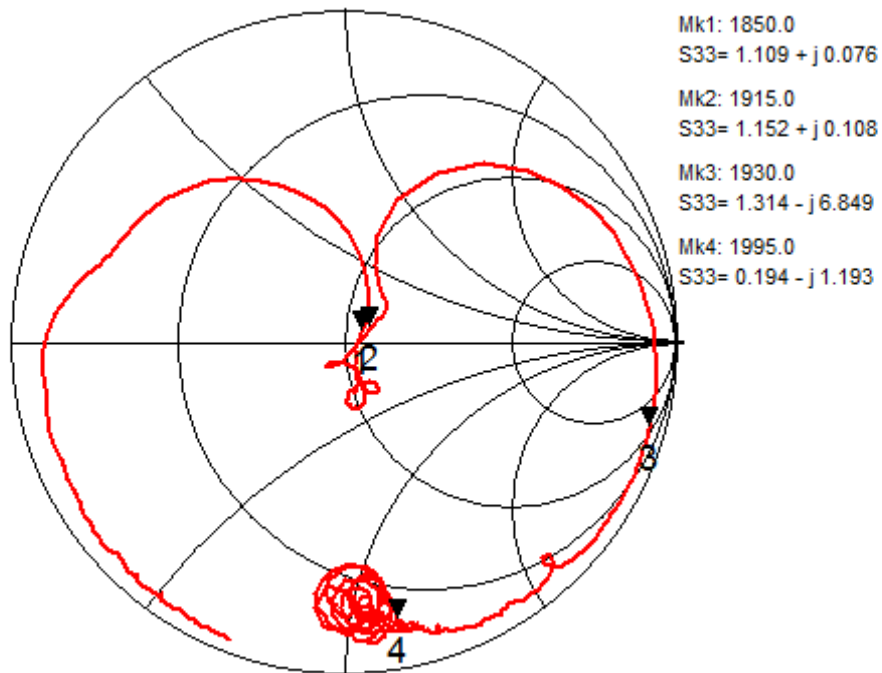
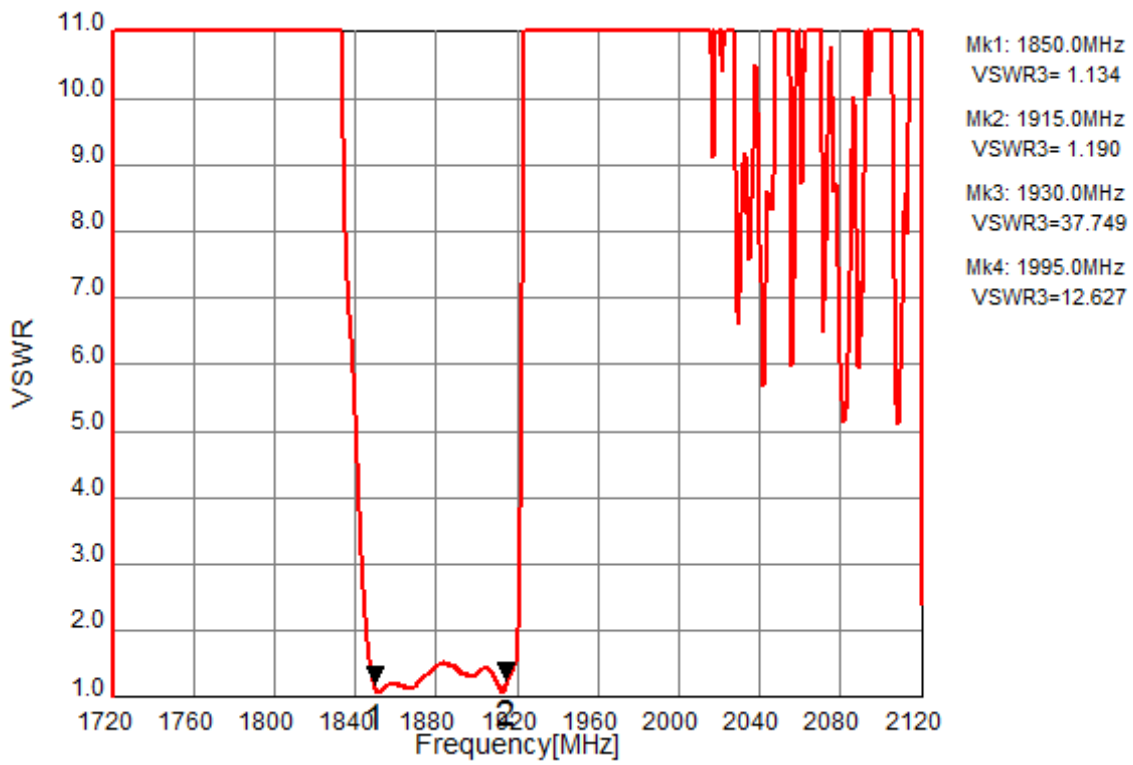

Rx Port

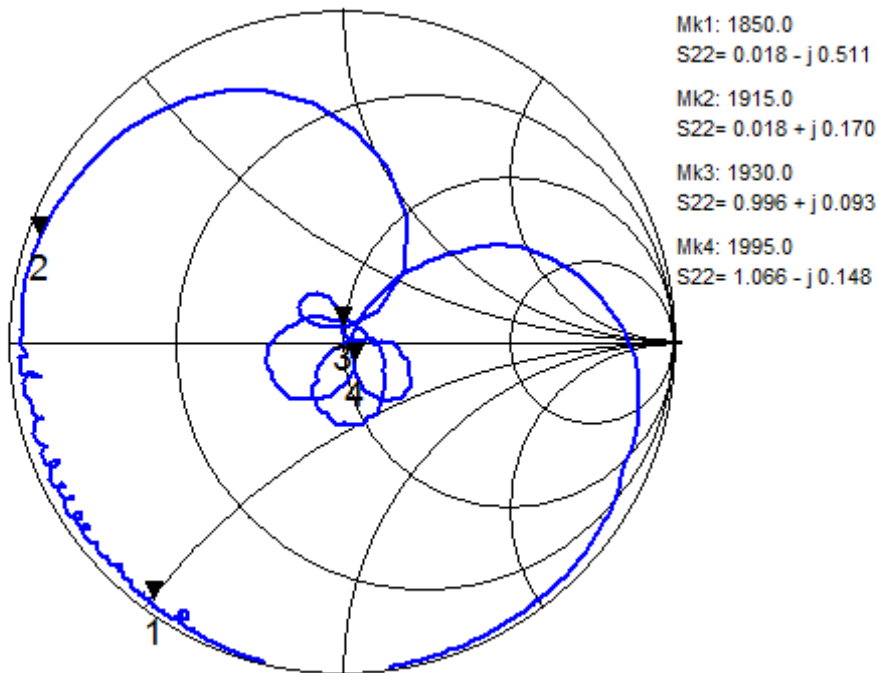
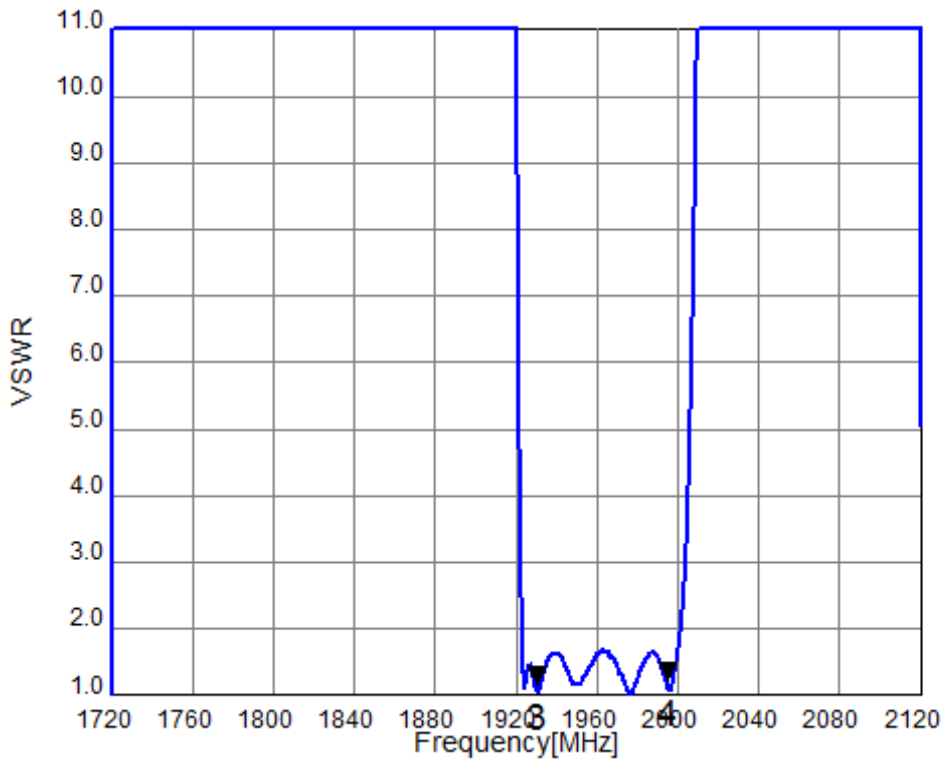

Ant Port

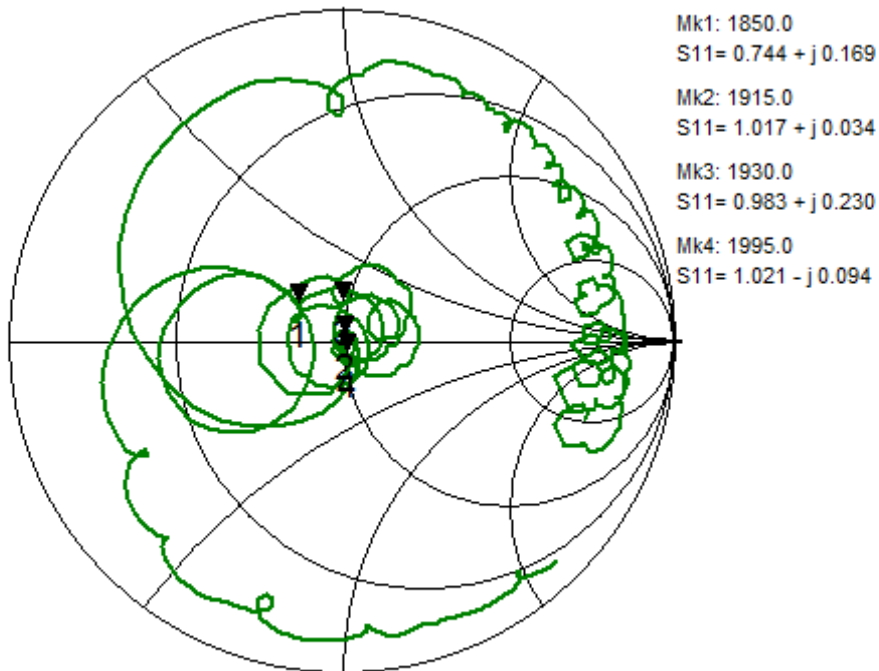
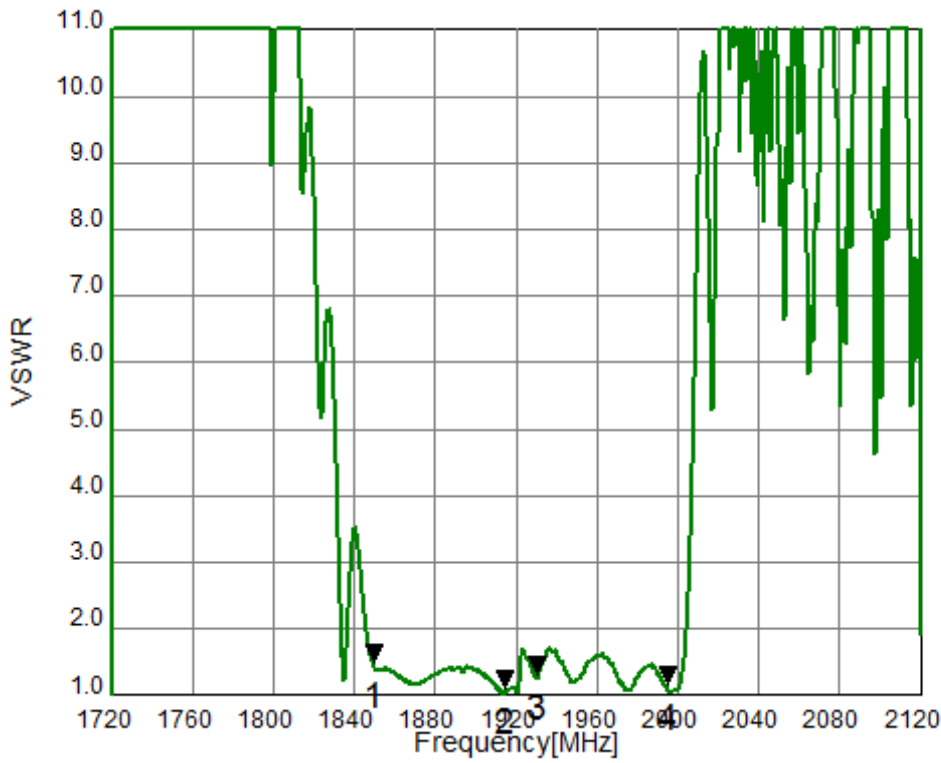

Tx to Ant (Wide span)

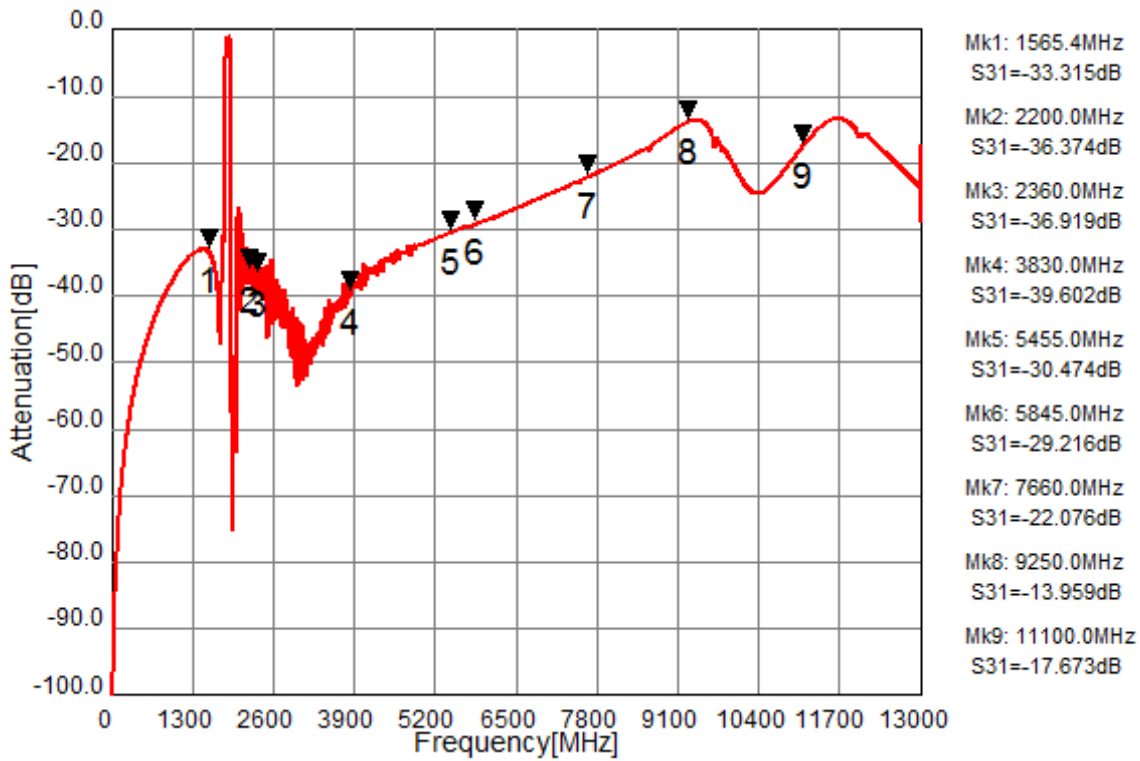

Ant to Rx (Wide span)

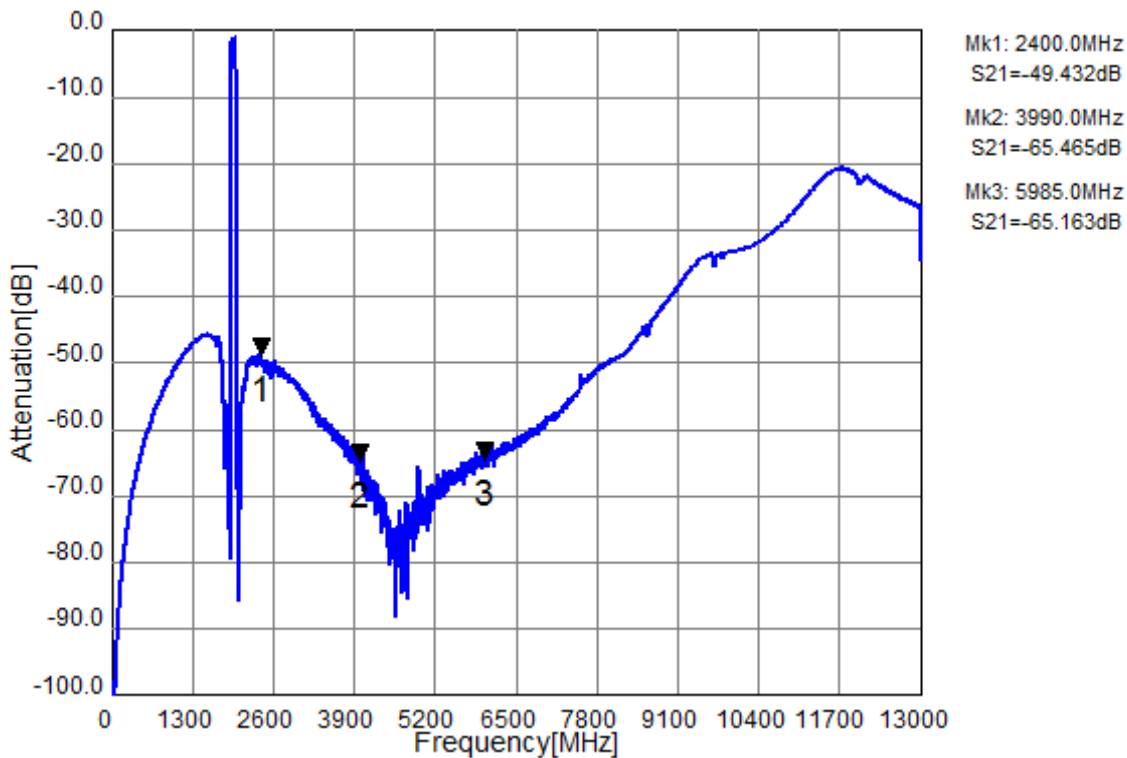

D. MEASUREMENT CIRCUIT:

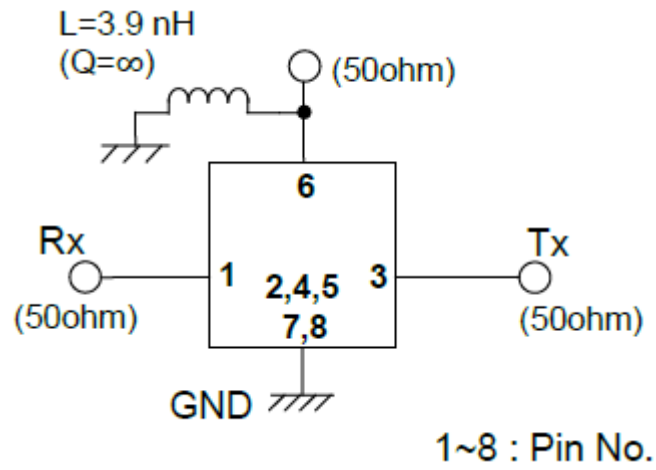

Recommended foot print pattern

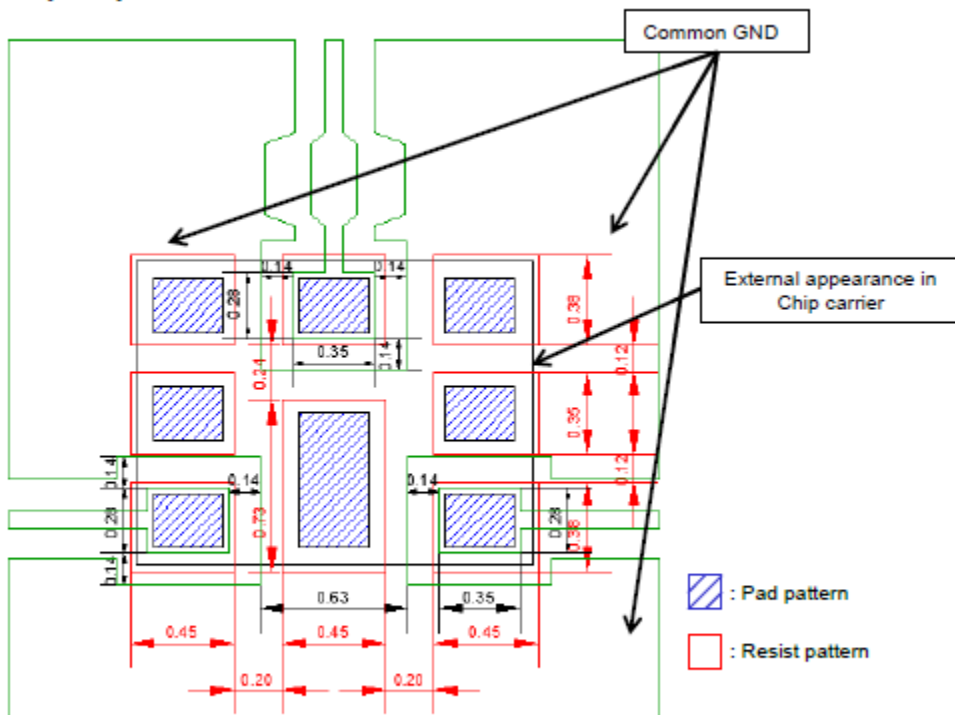
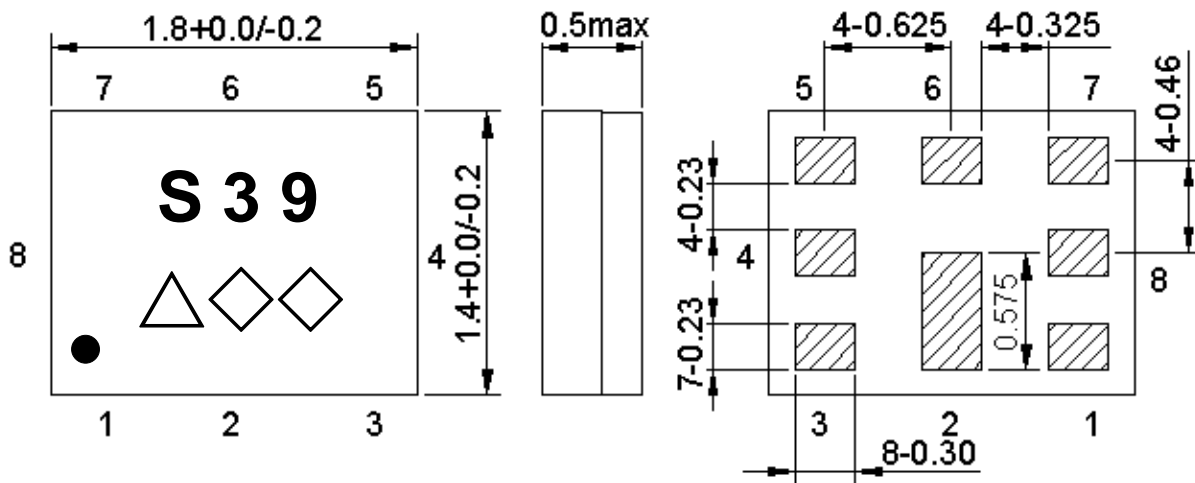

Figure 2. Recommended foot print pattern

E.OUTLINE DRAWING: (Mass Production)



Marking name : 39

△: Date code(2016 May → s ,....., 2019 Dec→m.)

◇◇: Lot Code.

Product Date Code. Follow below table.

Year	Jan	Feb	Mar	Apr	May	Jun	Jul	Aug	Sep	Oct	Nov	Dec
2016	n	p	q	r	s	t	u	v	w	x	y	z
2017	A	B	C	D	E	F	G	H	J	K	L	M
2018	N	P	Q	R	S	T	U	V	W	X	Y	Z
2019	a	b	c	d	e	f	g	h	j	k	l	m

Pin Configuration

Pin No.	Pin name	Description
1	Rx	Receiver Pin
2	GND	Ground Pin
3	Tx	Transmitter Pin
4	GND	Ground Pin
5	GND	Ground Pin
6	ANT	Antenna Pin
7	GND	Ground Pin
8	GND	Ground Pin

Top View (Sample Production):

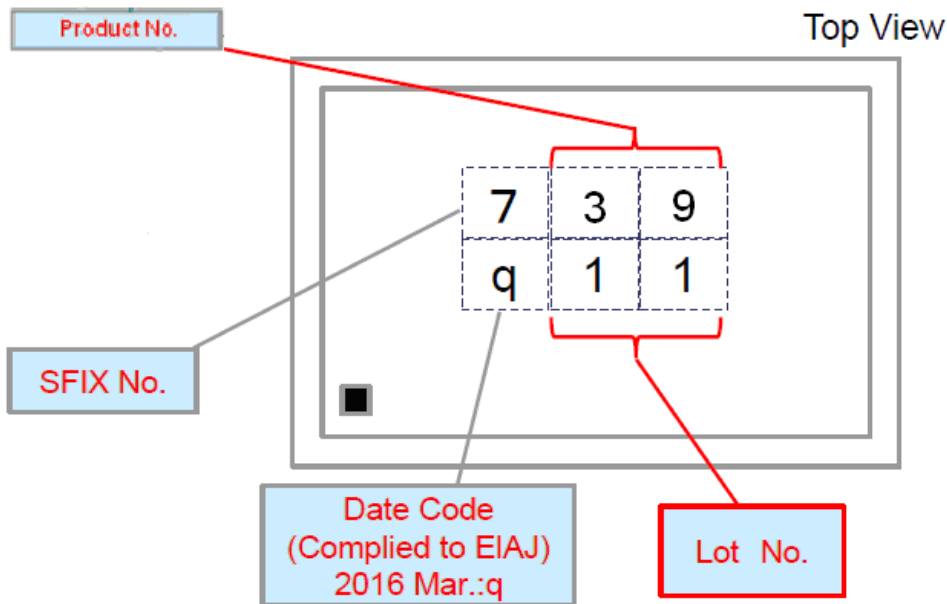

Lot No. is indicated by Arabic numerals 0 to 9 or characters A to Z and a to z (However, except I, O, l, I and o).

F. PACKING:

1. REEL DIMENSION

(Please refer to FR-75D10 for packing quantity)

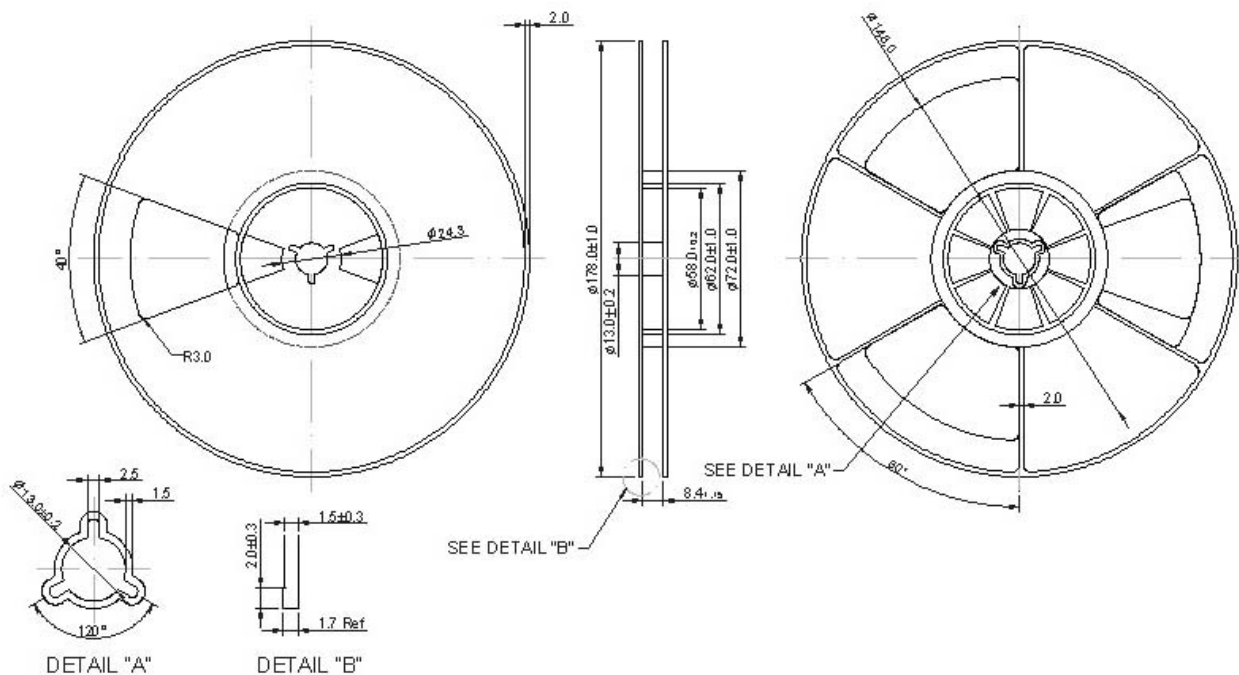

2.TAPE DIMENSION

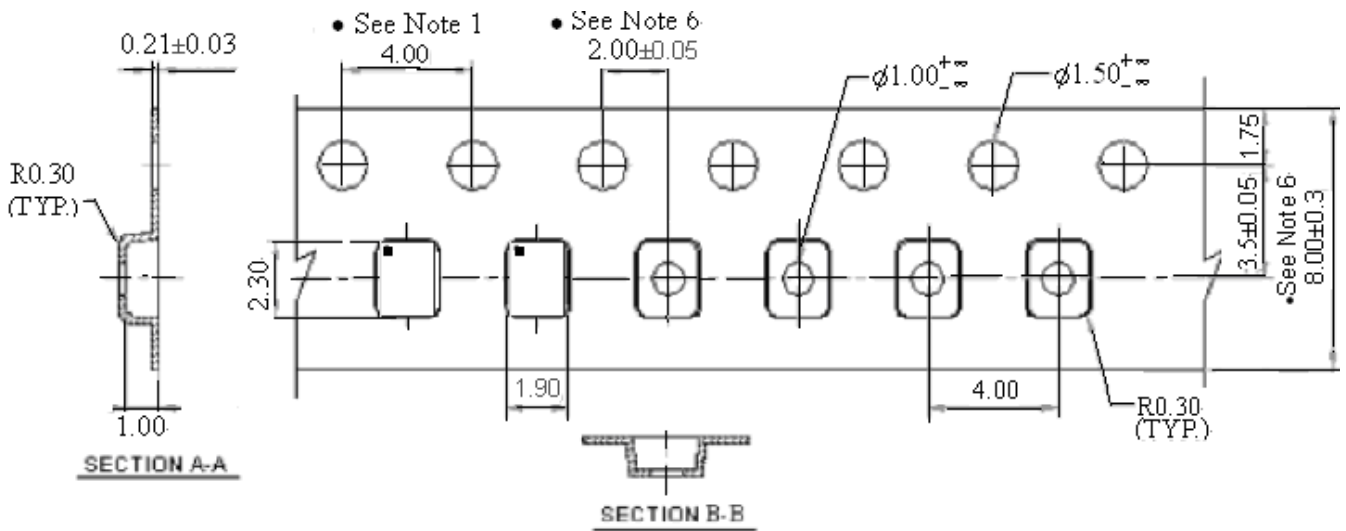

G. RECOMMENDED REFLOW PROFILE:

1. Preheating shall be fixed at 150~180°C for 60~90 seconds.
2. Ascending time to preheating temperature 150°C shall be 30 seconds min.
3. Heating shall be fixed at 220°C for 50~80 seconds and at 260°C +0/-5°C peak (20~40sec).
4. Time: 2 times.

