



TAI-SAW TECHNOLOGY CO., LTD.

No. 3, Industrial 2nd Rd., Ping-Chen Industrial District,
Taoyuan, 324, Taiwan, R.O.C.

TEL: 886-3-4690038 FAX: 886-3-4697532

E-mail: tstsales@mail.taisaw.com Web: www.taisaw.com

Product Specifications Approval Sheet

Product Name: SAW DPX 763 / 793MHz 10/10MHz BW Band14 SMD1.8X1.4 mm

TST Parts No.: TF0193B (This part is compliant by AEC-Q200)

Customer Part No.: _____

Customer signature required
Company: _____
Division: _____
Approved by : _____
Date: _____

Checked by: _____ Anne Chen *Anne Chen*

Approved by: _____ Andy Yu *Andy Yu*

Date: _____ 03 , 14 ,2019

1. Customer signed back is required before TST can proceed with sample build and receive orders.
2. Orders received without customer signed back will be regarded as agreement on the specifications.
3. Any specifications changes must be approved upon by both parties and a new revision of specifications shall be released to reflect the change



TAI-SAW TECHNOLOGY CO., LTD.

No. 3, Industrial 2nd Rd., Ping-Chen Industrial District,
Taoyuan, 324, Taiwan, R.O.C.

TEL: 886-3-4690038 FAX: 886-3-4697532

E-mail: tstsales@mail.taisaw.com Web: www.taisaw.com

SAW DPX 793/763MHz 10/10MHz BW Band14 SMD1.8X1.4 mm
MODEL NO.: TF0193B

REV. No.: 1.0

A. MAXIMUM RATING:

1. Input power : 30dBm (Ta=+50deg C,50000h,CW)
2. Maximum DC Voltage: +/-5 V
3. Operating temperature range: -30 °C to +85 °C
4. Storage temperature range: -30 °C to +85 °C
5. Moisture Sensitivity Level: Level 1 (MSL 1)
6. ESD 100V(MM) 200V(HBM)

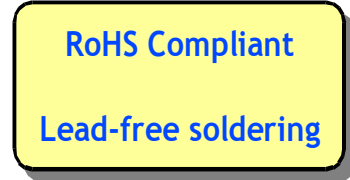

Electrostatic Sensitive Device (ESD)

B. ELECTRICAL CHARACTERISTICS:

Terminating impedance(Tx Port): 50 Ω (Single-ended)

Terminating impedance(Rx Port): 50 Ω (Single-ended)

Terminating impedance(Ant Port): 50 //12nH Ω (Single-ended)

Tx to ANT

Parameters Description		Unit	Minimum	Typical	Maximum	Note
Insertion Loss	788 ~ 798 MHz	dB(*1)	-	1.2	1.5	-30°C~+85°C
				1.2	1.8	
Ripple	788 ~ 798 MHz	dB	-	0.3	0.7	-30°C~+85°C
				0.3	0.9	
VSWR	Tx	-	-	1.3	2.0	-30°C~+85°C
				1.3	2.1	
	ANT			1.4	2.0	-30°C~+85°C
				1.4	2.1	

Attenuation:

758 ~ 768 MHz	dB	49	58	-	-
769 ~ 775 MHz	dB	17		-	45°C~+85°C
	dB	20	36	-	-30°C~+45°C
799 ~ 805 MHz	dB	0.7	1.1	-	
869 ~ 894 MHz	dB	40	44	-	
1554 ~ 1565 MHz	dB	42	47		
1565 ~ 1606 MHz	dB	44	47		
1800 ~ 1880 MHz	dB	44	50		
1930 ~ 2000 MHz	dB	46	52		
2364 ~ 2394 MHz	dB	33	52		

2400 ~ 2500 MHz	dB	32	50		
3152 ~ 3192 MHz	dB	27	42		
4900 ~ 5950 MHz	dB	10	17		

ANT to Rx

Parameters Description		Unit	Minimum	Typical	Maximum	Note	
Insertion Loss	758.25 ~ 767.75 MHz	dB(*1)	-	2.2	3.2	-30°C~+85°C	
		dB(*1)		2.2	3.5		
	758 ~ 768 MHz	dB		2.3	3.3	-30°C~+85°C	
		dB		2.3	3.6		
Ripple	758 ~ 768 MHz	dB	-	0.7	2.0	-30°C~+85°C	
		dB		0.7	2.3		
VSWR	Tx	758 ~ 768 MHz	-	-	1.6	2.0	-30°C~+85°C
					1.6	2.2	
	ANT	758 ~ 768 MHz			1.6	2.0	-30°C~+85°C
			-	-	1.6	2.2	

Attenuation:

10 ~ 698 MHz	dB	45	55	-	-
698 ~ 716 MHz	dB	43	56		
716 ~ 728 MHz	dB	27	39		
776~ 777.34 MHz	dB	22		-	-30°C~ 0°C
	dB	35	41	-	0°C~+85°C
777.34 ~ 780 MHz	dB	35	40	-	
780 ~ 787 MHz	dB	35	41	-	
788 ~ 798 MHz	dB	50	61		
798 ~ 6000 MHz	dB	30	36		
1546 ~ 1566 MHz	dB	46	53		
1710 ~ 1980 MHz	dB	42	52		
2334 ~ 2364 MHz	dB	38	50		
2400 ~ 2690 MHz	dB	40	50		

Tx to Rx

Isolation	788 ~ 798 MHz	dB	59	63	-	
	758 ~ 768 MHz	dB	54	57	-	

(*1) Specification of insertion loss excludes loss that comes from the test board.

C. Frequency Characteristics:

Tx to Ant

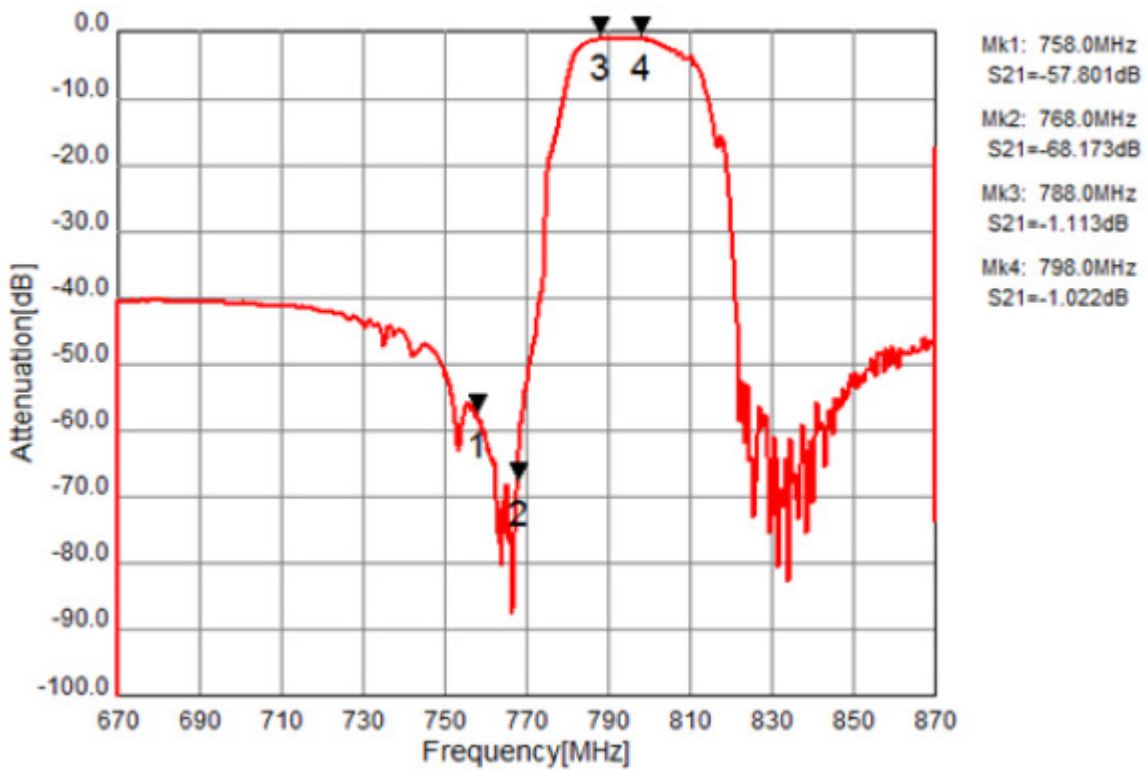

Ant to Rx

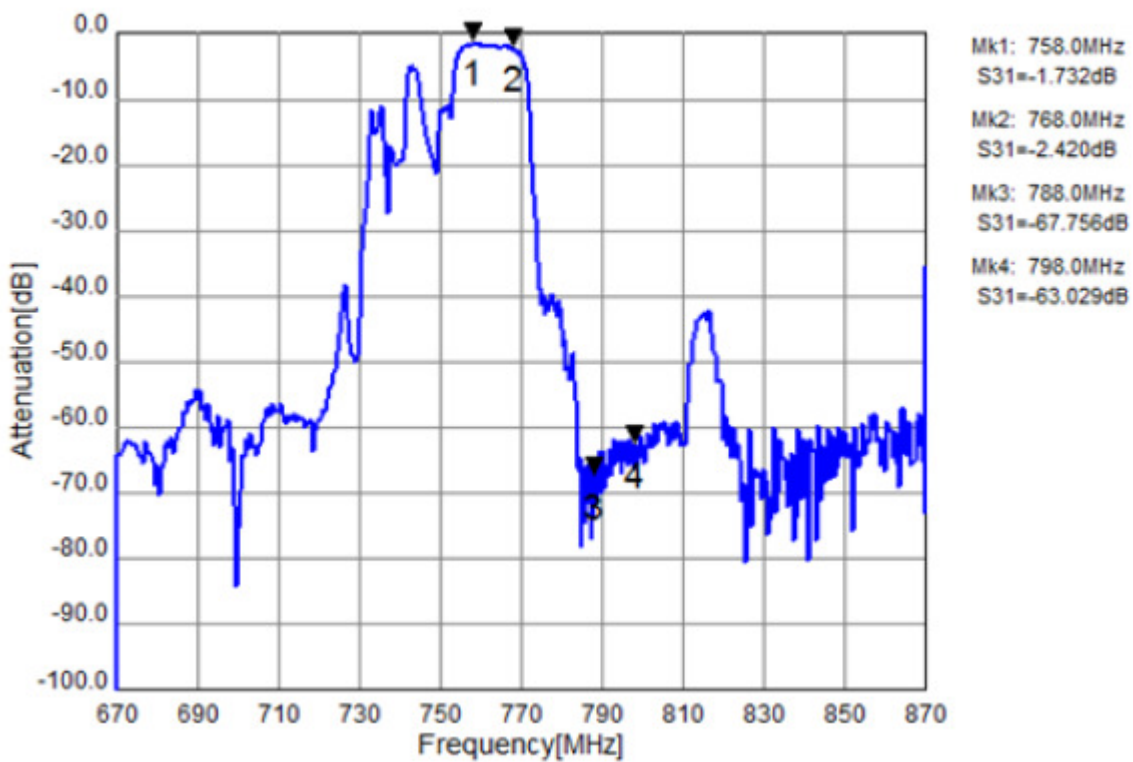

Tx to Ant, Ant to Rx

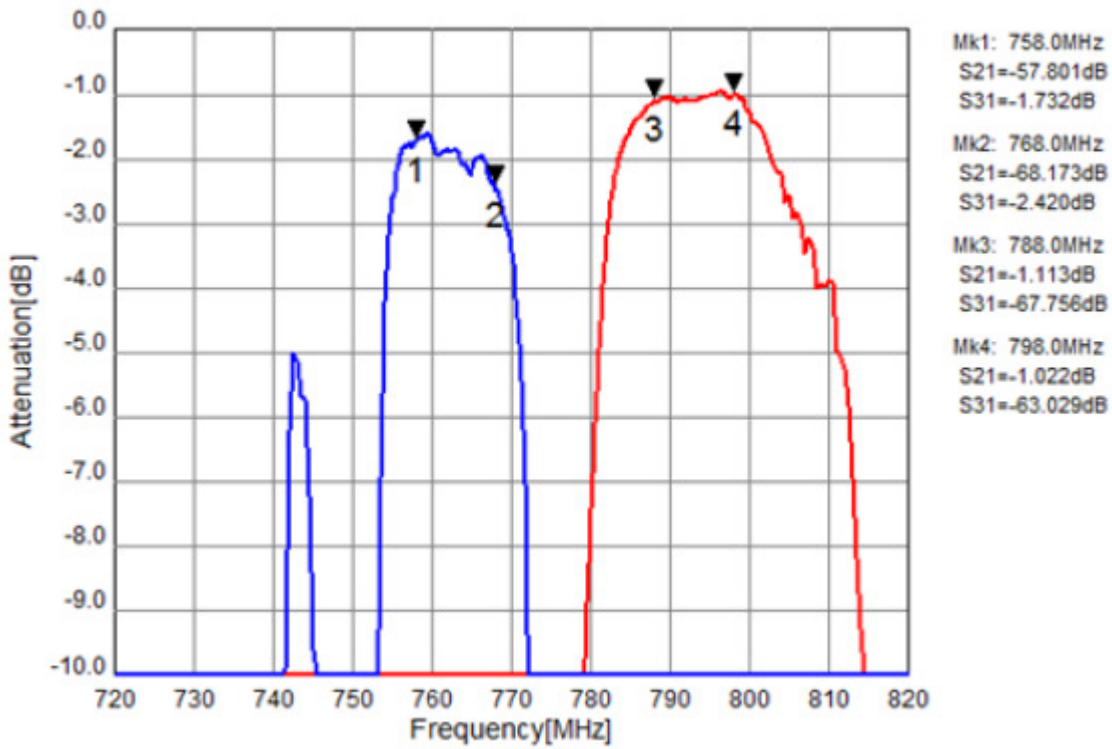

Tx to Rx Isolation

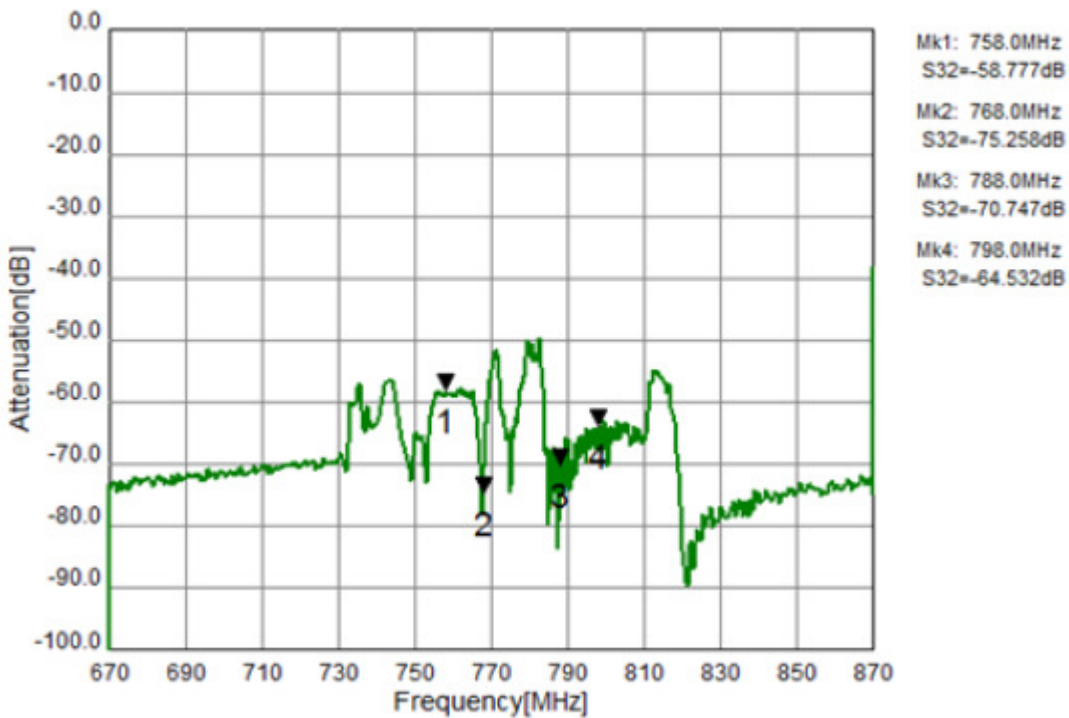

Tx Port

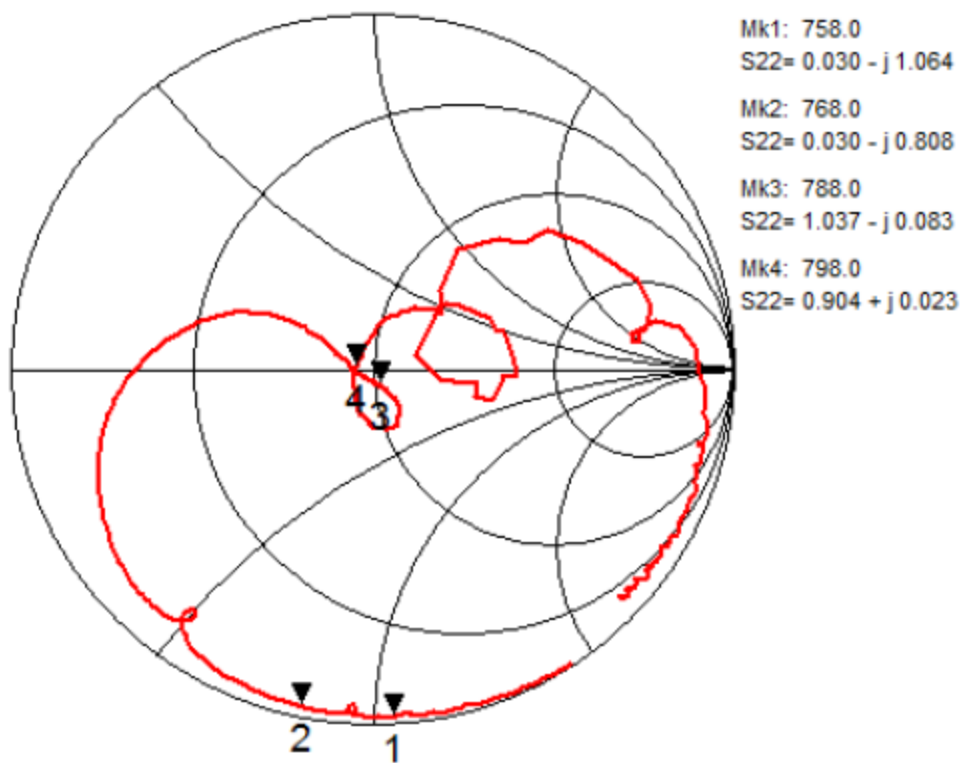
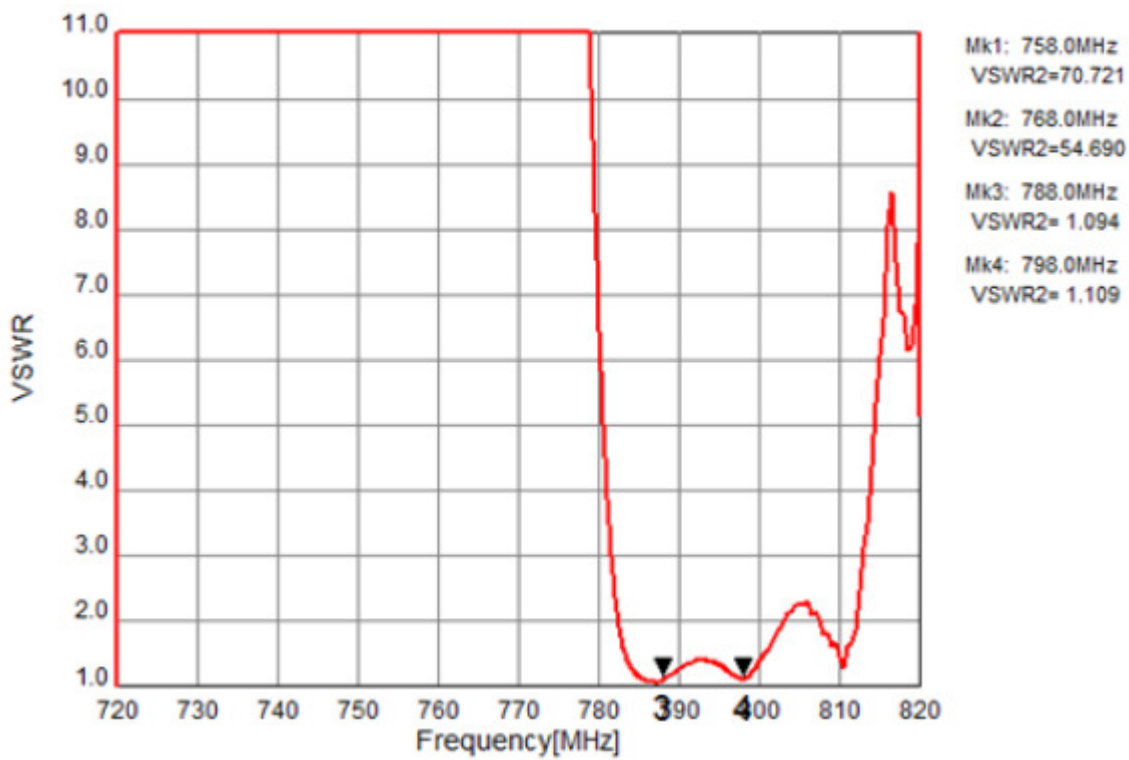

Rx Port

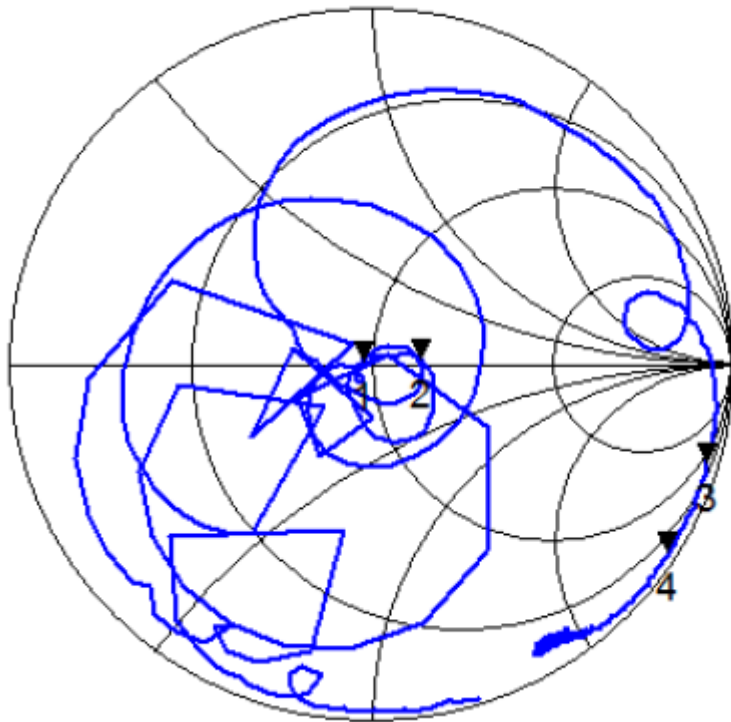
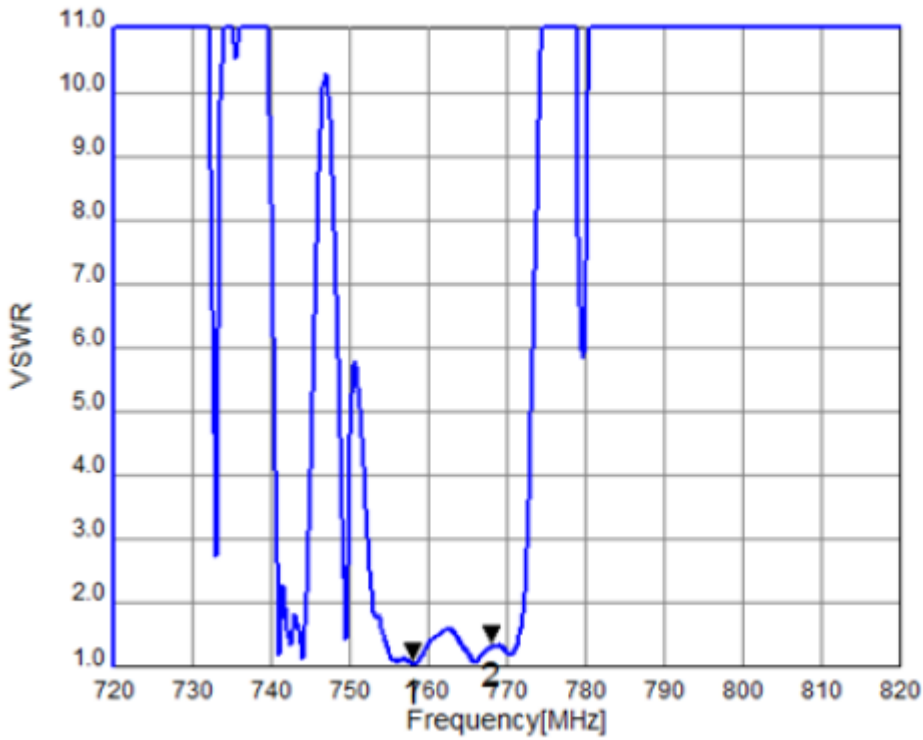

Marker	Frequency [MHz]	S33
Mk1	758.0	$0.947 + j0.014$
Mk2	768.0	$1.311 + j0.045$
Mk3	788.0	$0.793 - j6.651$
Mk4	798.0	$0.164 - j3.345$

Ant Port

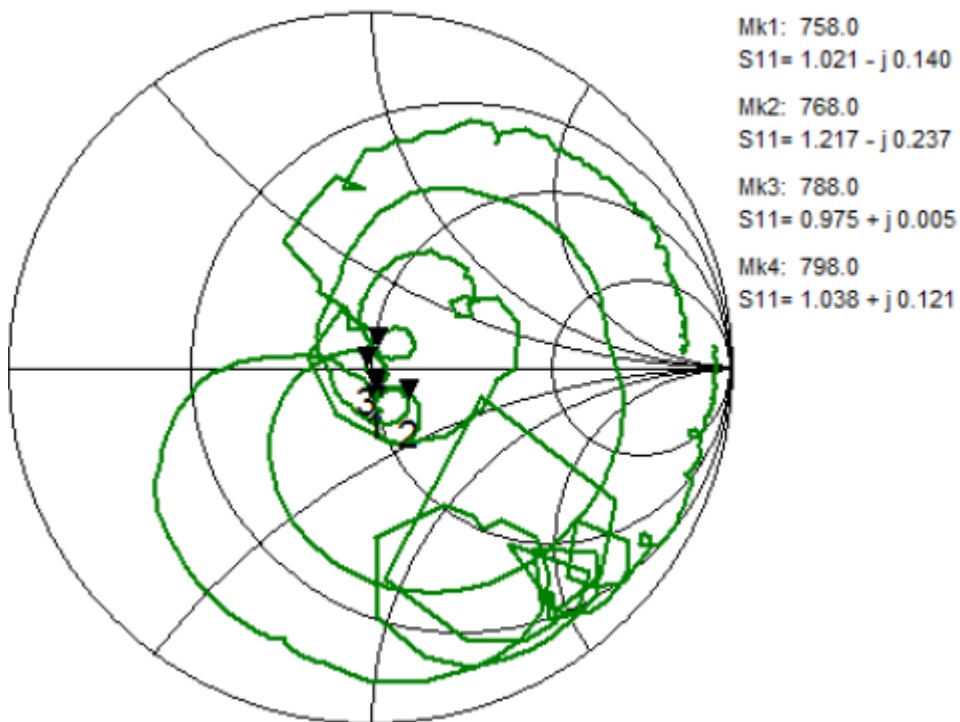
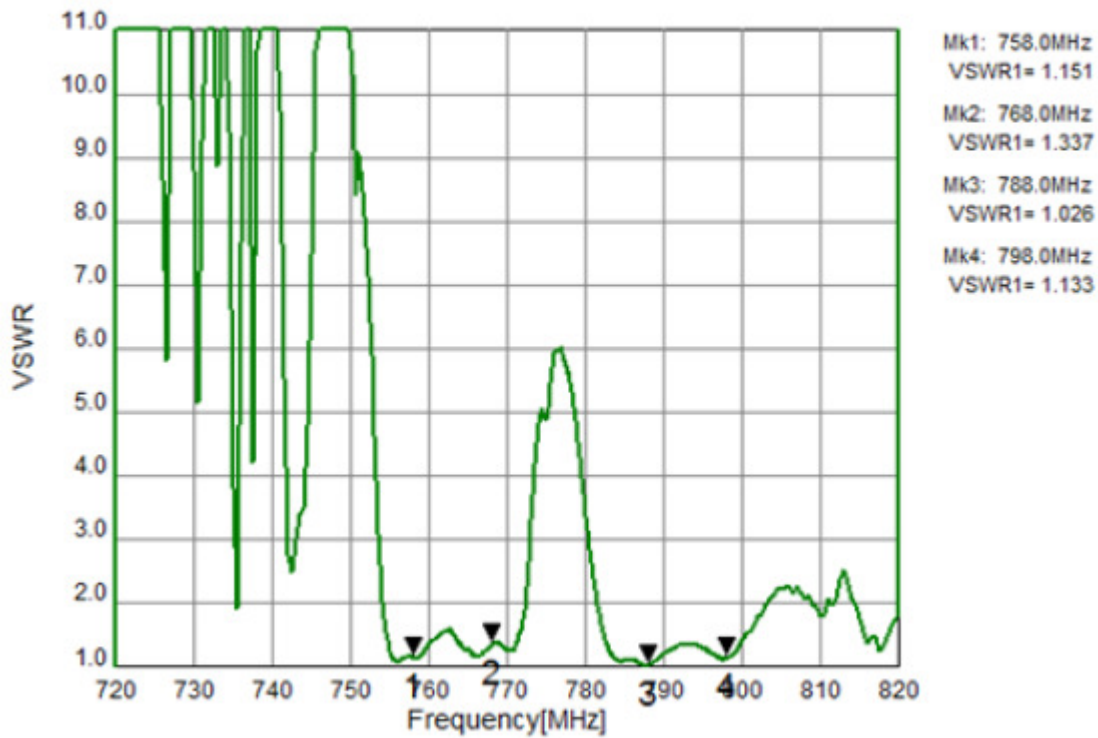

Tx to Ant (Wide span)

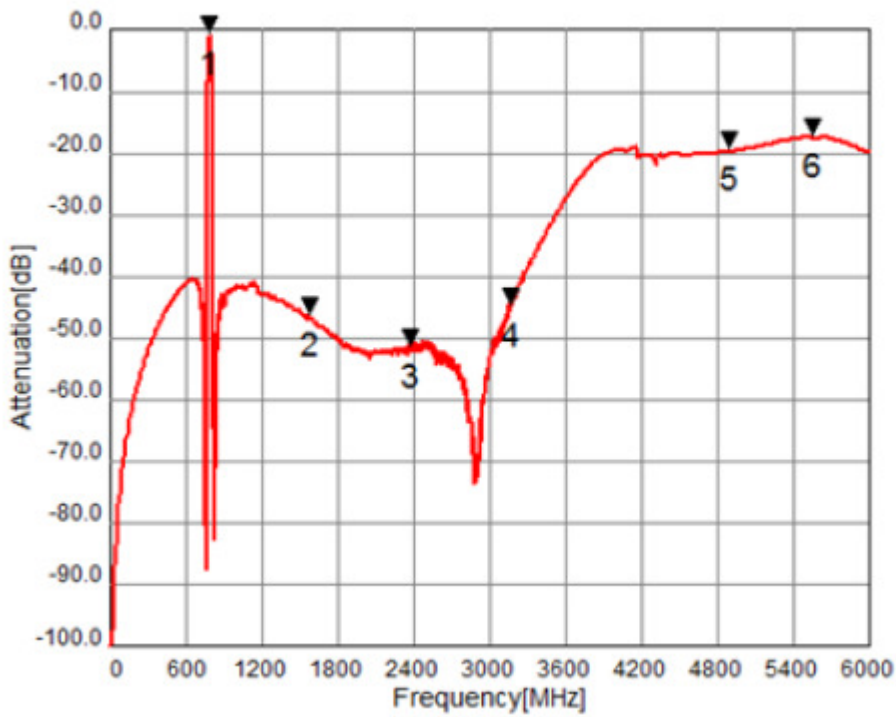

Ant to Rx (Wide span)

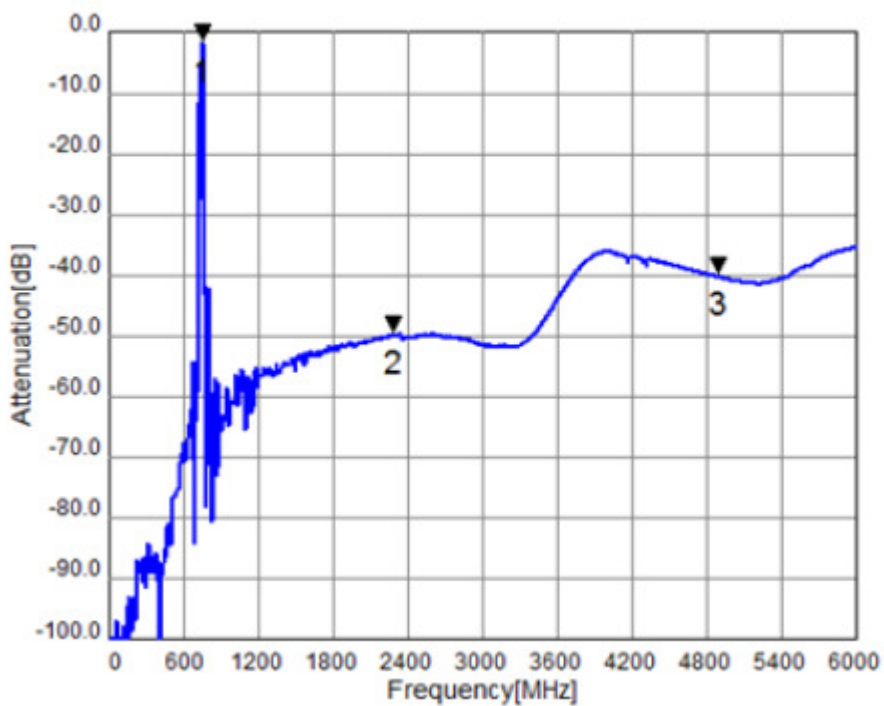

Tx to Rx Isolation (Wide span)

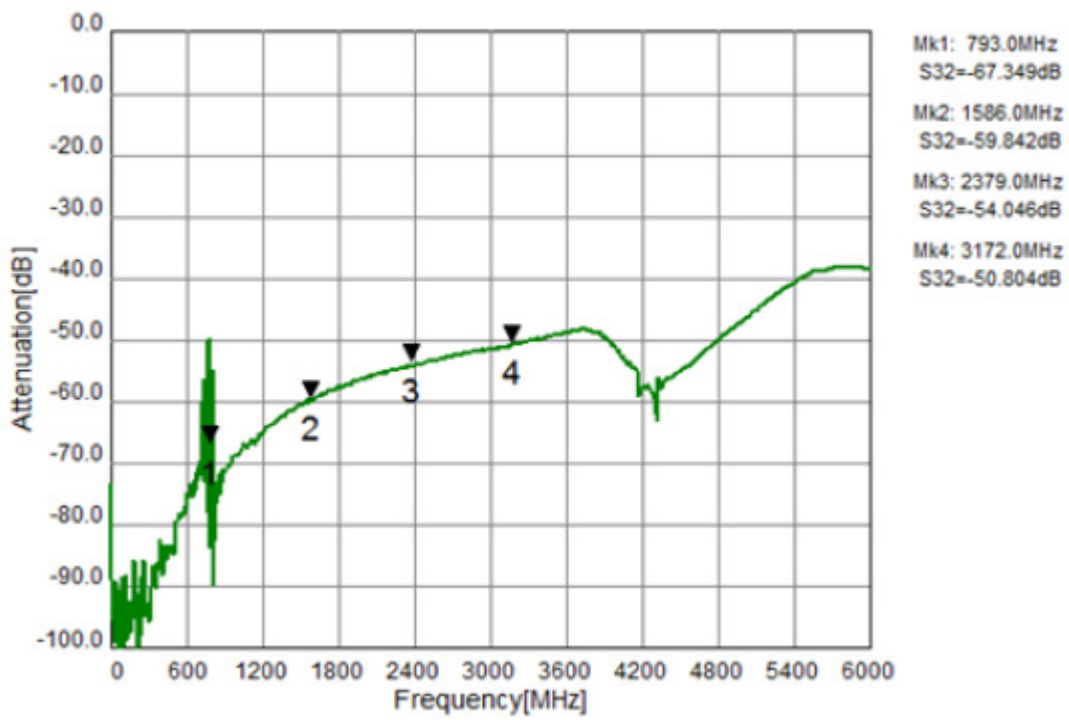

D. MEASUREMENT CIRCUIT:

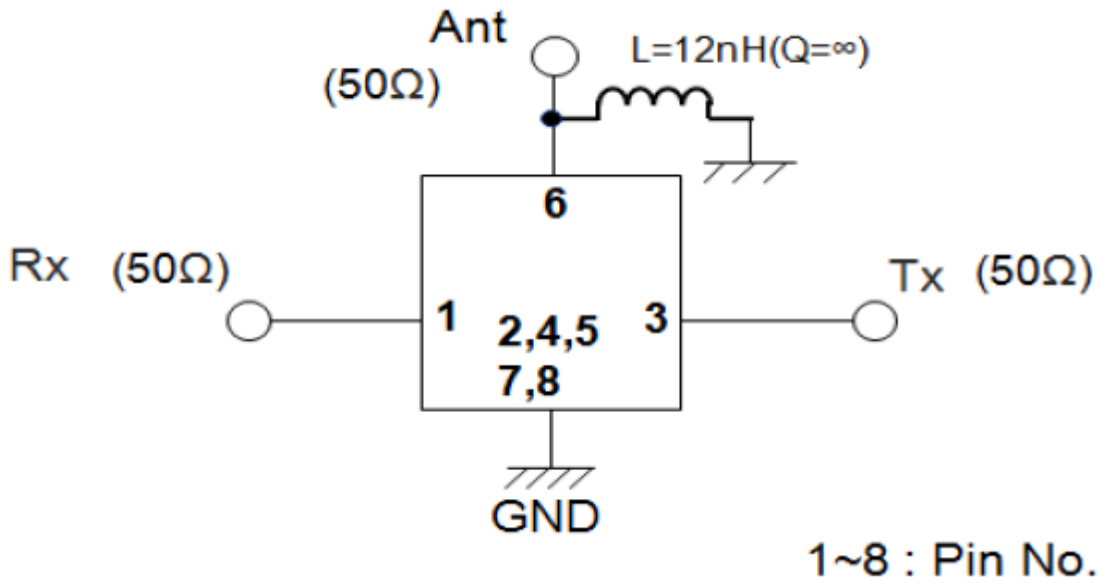

E. PCB Footprint:

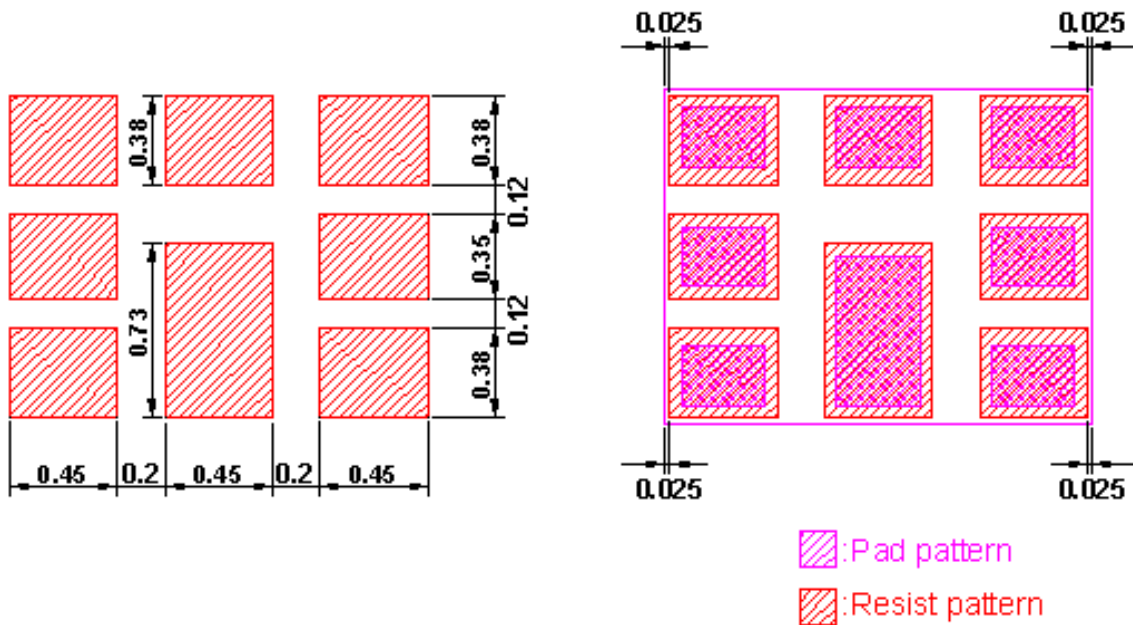

F.OUTLINE DRAWING: (Mass Production)

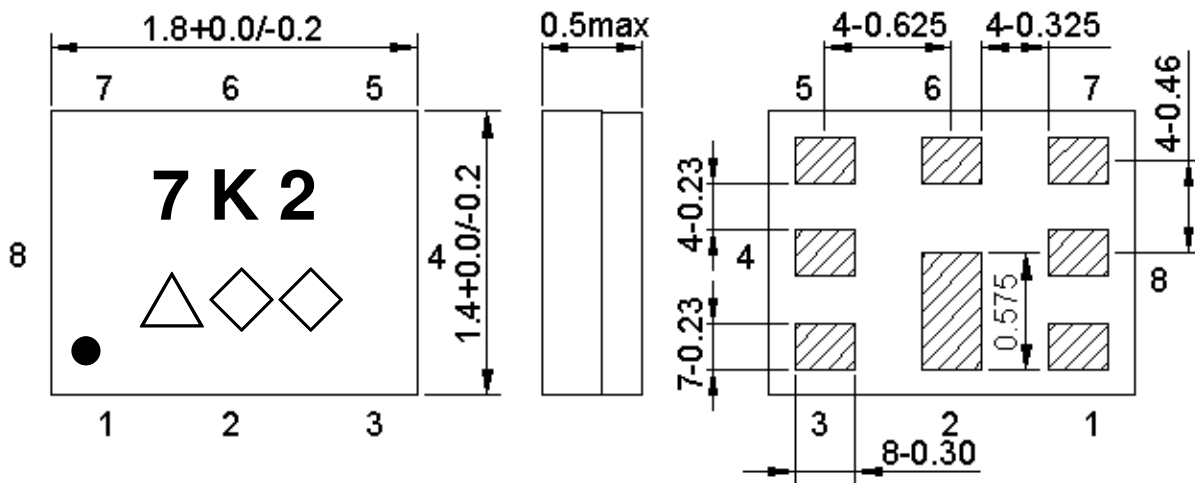

Marking name :7K2

△: Date code(2016 May → s ,....., 2019 Dec→m.)

◇◇: Lot Code.

Product Date Code. Follow below table.

Year	Jan	Feb	Mar	Apr	May	Jun	Jul	Aug	Sep	Oct	Nov	Dec
2016	n	p	q	r	s	t	u	v	w	x	y	z
2017	A	B	C	D	E	F	G	H	J	K	L	M
2018	N	P	Q	R	S	T	U	V	W	X	Y	Z
2019	a	b	c	d	e	f	g	h	j	k	l	m
2020	n	p	q	r	s	t	u	v	w	x	y	z
2021	A	B	C	D	E	F	G	H	J	K	L	M

Pin assignment

Pin No.	Pin name	Description
1	Rx	Receiver
2	GND	Ground
3	Tx	Transmitter
4	GND	Ground
5	GND	Ground
6	Ant	Antenna
7	GND	Ground
8	GND	Ground

Figure 1. Dimensions and Pin assignment

G. PACKING:

1. REEL DIMENSION

(Please refer to FR-75D10 for packing quantity)

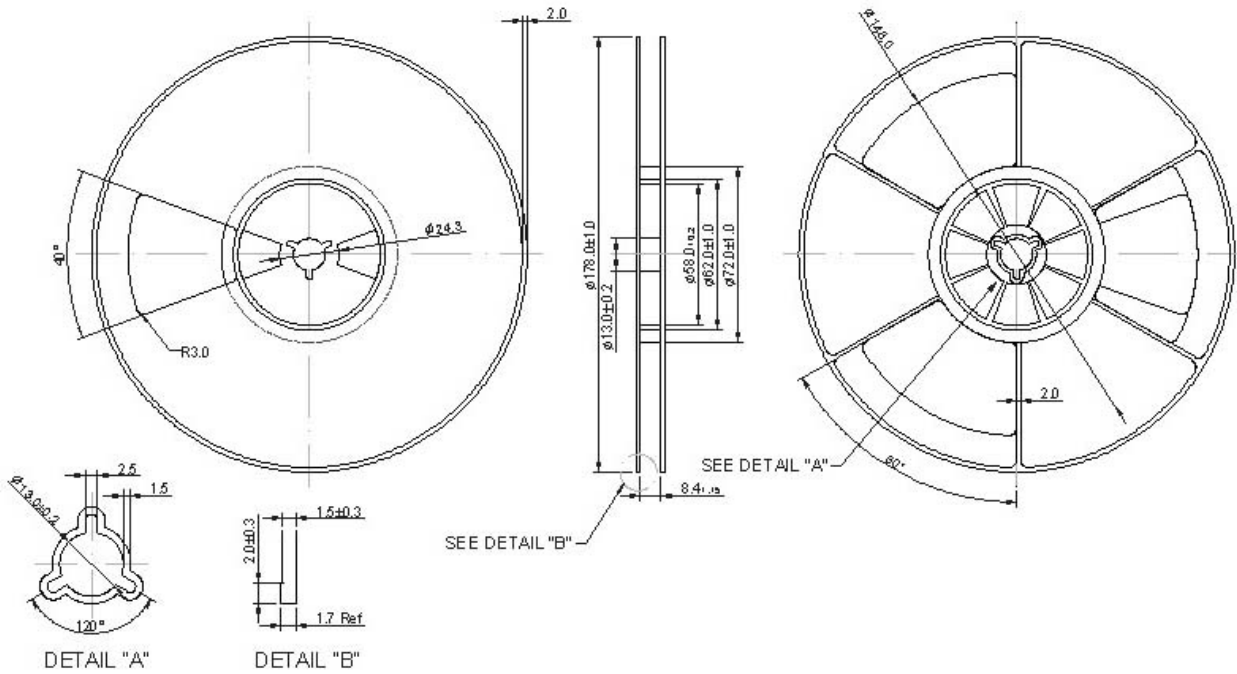

2. TAPE DIMENSION

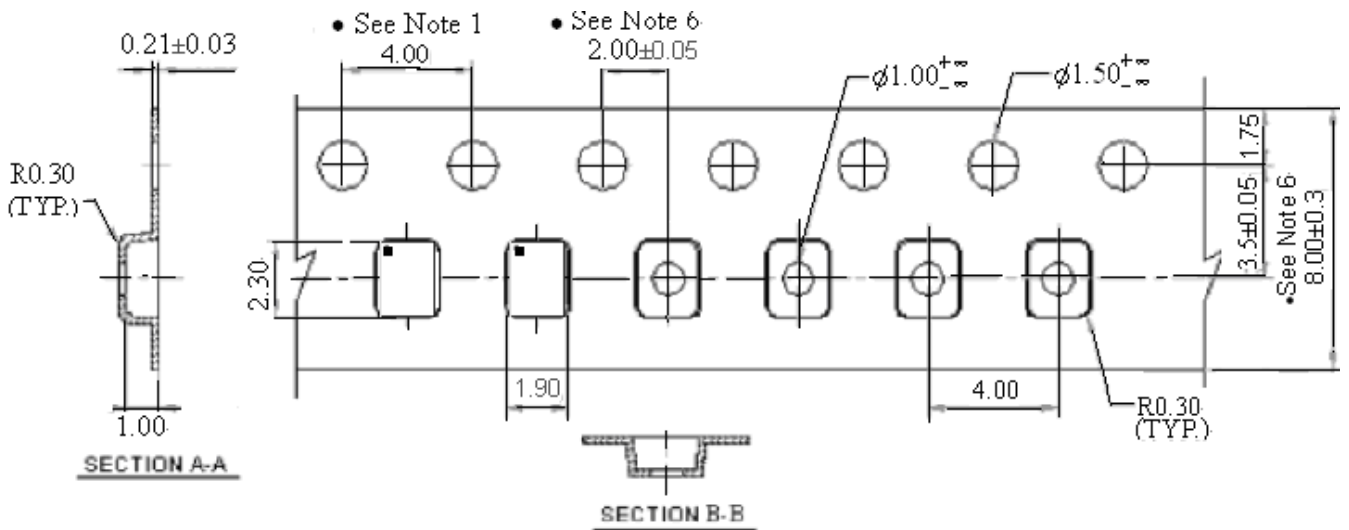

H. RECOMMENDED REFLOW PROFILE:

1. Preheating shall be fixed at 150~180°C for 60~90 seconds.
2. Ascending time to preheating temperature 150°C shall be 30 seconds min.
3. Heating shall be fixed at 220°C for 50~80 seconds and at 260°C +0/-5°C peak (20~40sec).
4. Time: 2 times.

