



TAI-SAW TECHNOLOGY CO., LTD.

No. 3, Industrial 2nd Rd., Ping-Chen Industrial District,
Taoyuan, 324, Taiwan, R.O.C.

TEL: 886-3-4690038 FAX: 886-3-4697532

E-mail: tstsales@mail.taisaw.com Web: www.taisaw.com

Product Specifications Approval Sheet

Product Name: SAW DPX 1455.4/1503.4 MHz Band 21 SMD 1.8x1.4 mm (BW=15/15 MHz)

TST Parts No.: TF0198A

Customer Part No.: _____

Customer signature required
Company: _____
Division: _____
Approved by : _____
Date: _____

Checked by: _____ Hayley Chou *Hayley Chou*

Approved by: _____ Andy Yu *Andy Yu*

Date: _____ 2020/11/24

1. Customer signed back is required before TST can proceed with sample build and receive orders.
2. Orders received without customer signed back will be regarded as agreement on the specifications.
3. Any specifications changes must be approved upon by both parties and a new revision of specifications shall be released to reflect the changes



TAI-SAW TECHNOLOGY CO., LTD.

No. 3, Industrial 2nd Rd., Ping-Chen Industrial District,
Taoyuan, 324, Taiwan, R.O.C.

TEL: 886-3-4690038 FAX: 886-3-4697532

E-mail: tstsales@mail.taisaw.com Web: www.taisaw.com

SAW DPX 1455.4/1503.4 MHz

MODEL NO.:TF0198A

REV. NO.:3.0

A. MAXIMUM RATING:

- Input Power Level (Tx to ANT 1447.9~1462.9 MHz):
29 dBm, CW , +50 °C, 10000 h
29 dBm, LTE 5 MHz 1RB, +50 °C, 10000 h
30 dBm, CW , +50 °C, 5000 h
30 dBm, LTE 5 MHz 1RB, +50 °C, 5000 h
- DC Voltage: +/-5 V
- Operating Temperature: -30 °C to +85 °C
- Storage Temperature: -30 °C to +85 °C
- Moisture Sensitive Level: Level 1 (MSL1)
- ESD: 50 V(MM), 100 V(HBM)

RoHS Compliant
Lead-free soldering

Electrostatic Sensitive Device (ESD)

B. ELECTRICAL CHARACTERISTICS:

- Terminating impedance (Tx port): 50 Ω
- Terminating impedance (Rx port): 50 Ω
- Terminating impedance (Ant port): 50//8.5nH Ω

Tx to Ant

Item	Unit	Min.	Typ.	Max.	Remark
Insertion Loss (1447.9~1462.9 MHz)	dB(*1)	-	1.3	1.8	-
Amplitude Ripple (1447.9~1462.9 MHz)	dB	-	0.4	1.0	-
VSWR Tx (1447.9~1462.9 MHz)	-	-	1.3	2.0	-
VSWR Ant (1447.9~1462.9 MHz)	-	-	1.3	2.0	-
Attenuation (Reference level from 0 dB)					
1475.9 ~ 1495.9 MHz	dB	5	9	-	+15~+70 °C
1495.9 ~ 1510.9 MHz	dB	50	60	-	-
1559 ~ 1563 MHz	dB	35	43	-	-
1565.42 ~ 1573.38 MHz	dB	36	50	-	-
1573.37 ~ 1577.47 MHz	dB	40	55	-	-
1577.46 ~ 1585.42 MHz	dB	37	50	-	-
1597.55 ~ 1605.89 MHz	dB	40	45	-	-
2400 ~ 2500 MHz	dB	38	49	-	-
2895.8 ~ 2925.8 MHz	dB	33	40	-	-
4343.7 ~ 4388.7 MHz	dB	22	30	-	-

Ant to Rx

Item	Unit	Min.	Typ.	Max.
Insertion Loss (1495.9~1510.9 MHz)	dB(*1)	-	1.3	1.8
Amplitude Ripple (1495.9~1510.9 MHz)	dB	-	0.3	1.0
VSWR Ant (1495.9~1510.9 MHz)	-	-	1.4	2.0
VSWR Rx (1495.9~1510.9 MHz)	-	-	1.4	2.0
Attenuation (Reference level from 0 dB)				
1447.9 ~ 1462.9 MHz	dB	52	58	-
2400 ~ 2500 MHz	dB	38	42	-
2991.8 ~ 3021.8 MHz	dB	40	45	-
4487.7 ~ 4532.7 MHz	dB	45	53	-

Tx to Rx

Item	Unit	Min.	Typ.	Max.	Remark	
Isolation (Reference level from 0 dB)	1447.9 ~ 1462.9 MHz	dB	55	60	-	-
	1495.9 ~ 1510.9 MHz	dB	55	60	-	-30~+65 °C
		dB	53	-	-	+65~+85 °C

(*1) Specification of insertion loss excludes loss that comes from the test board.

C. MEASUREMENT CIRCUIT:

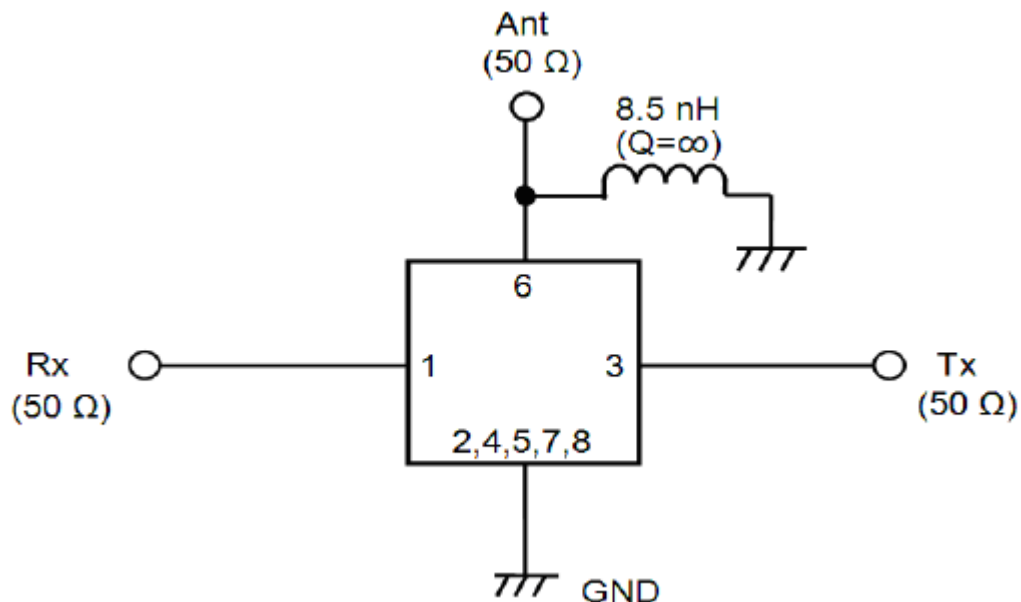

D. FREQUENCY CHARACTERISTICS:

Tx to Ant

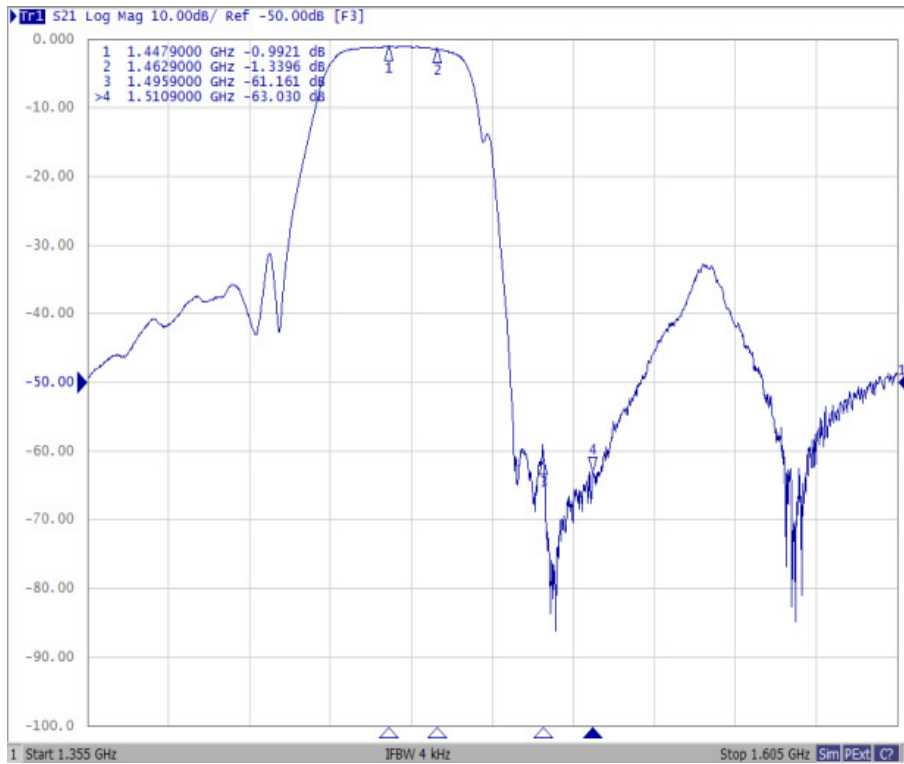

Ant to Rx

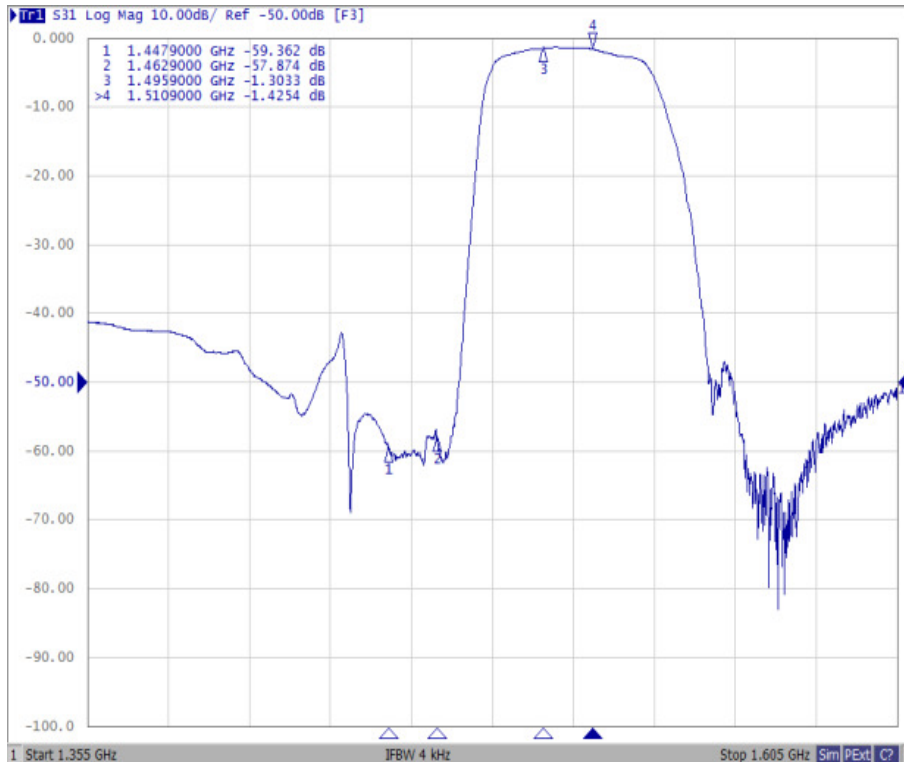

Tx to Ant, Ant to Rx

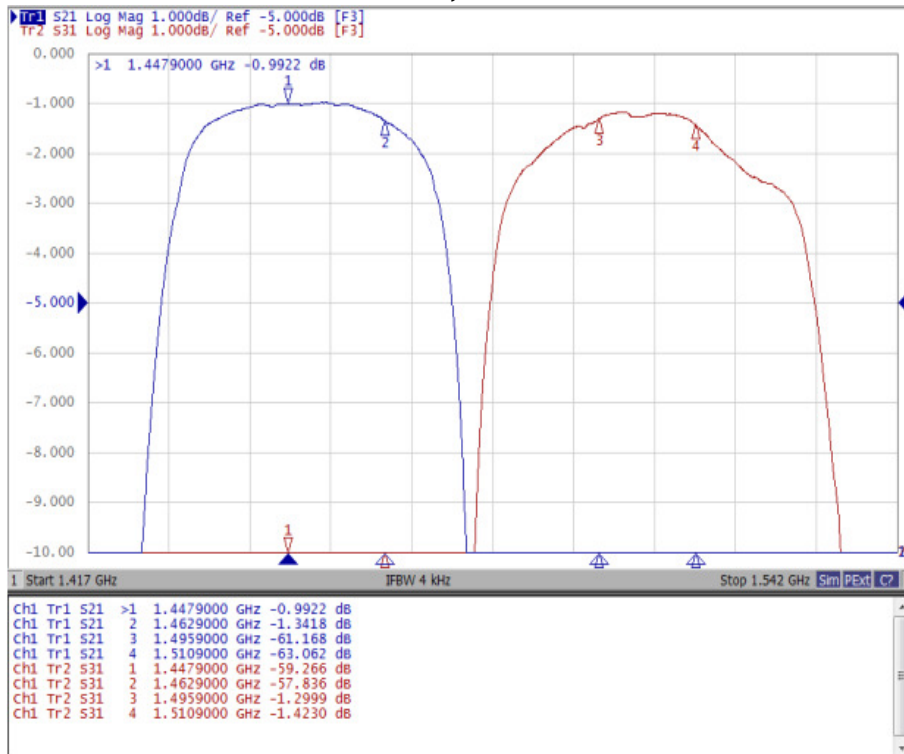

Tx to Rx Isolation

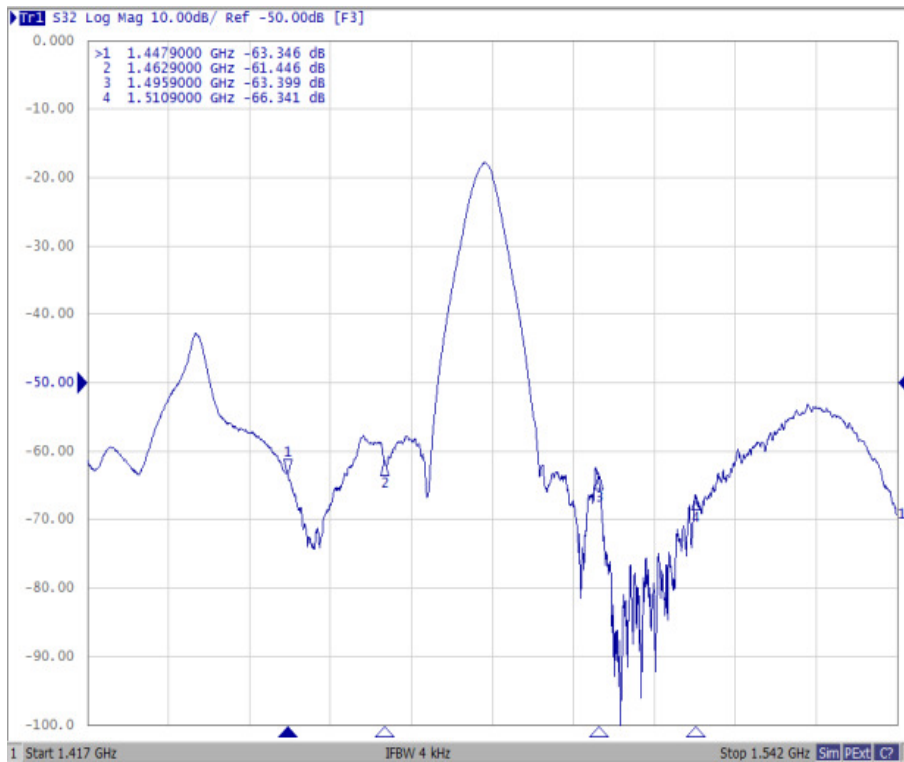

Tx Port

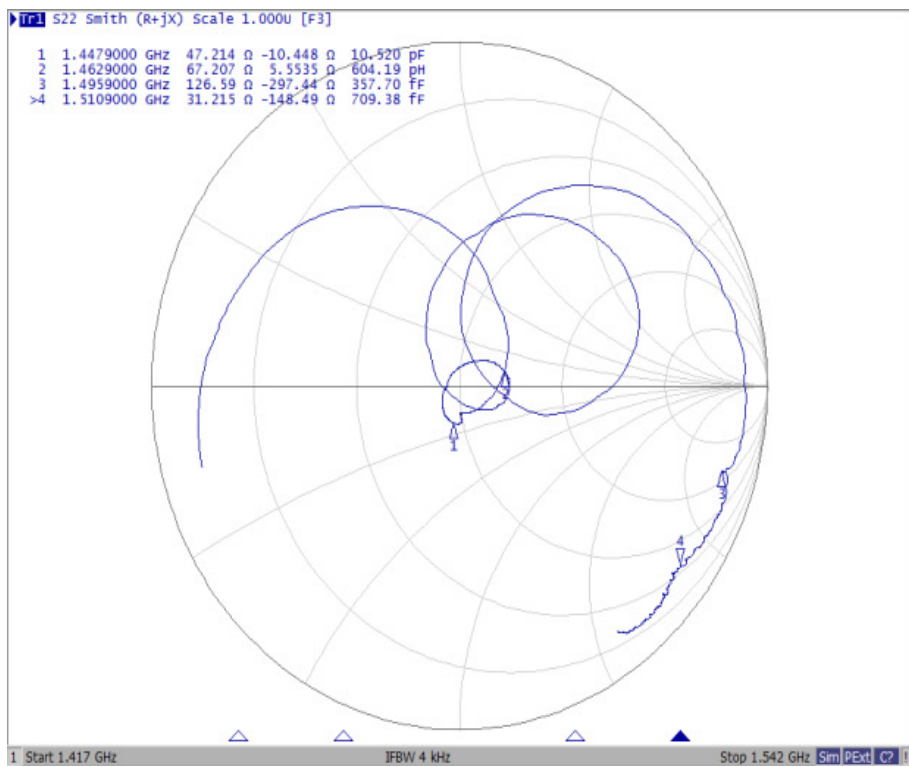
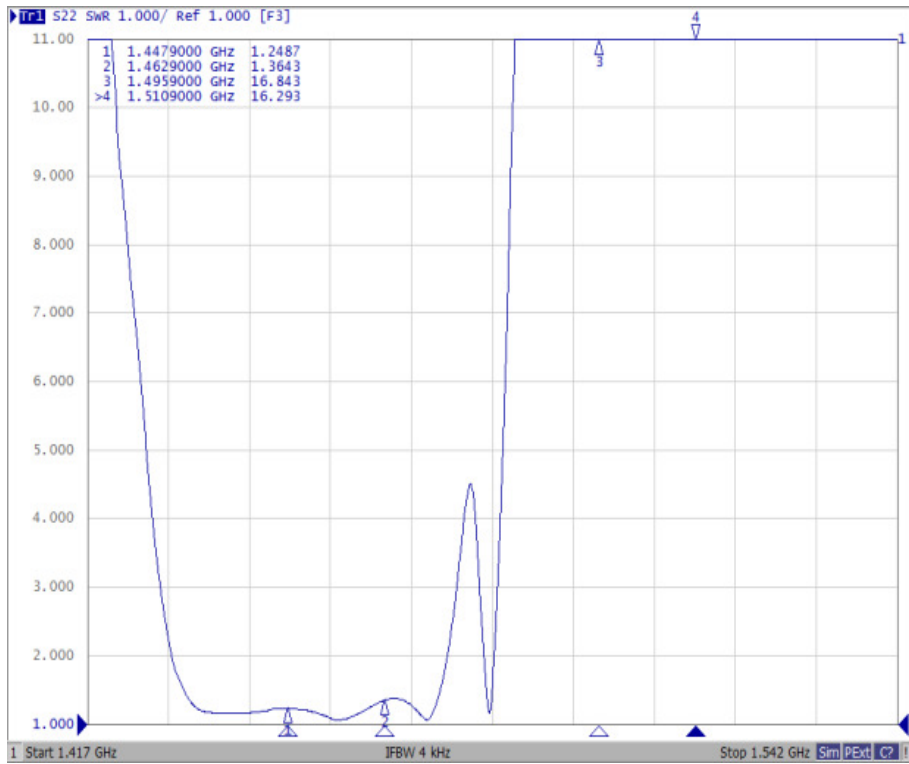

Rx Port

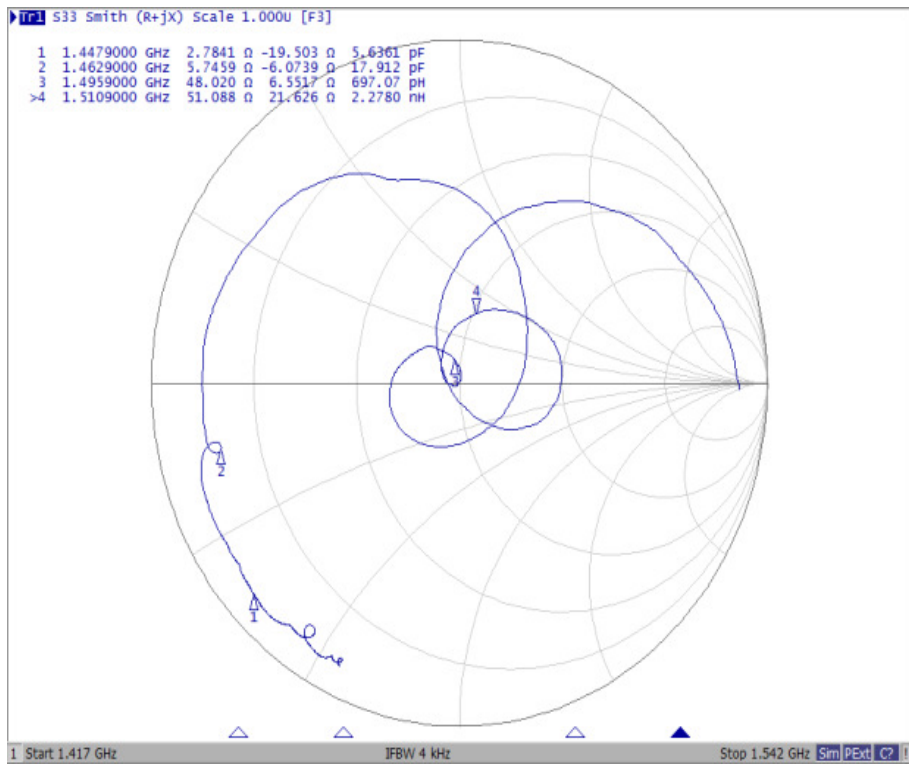
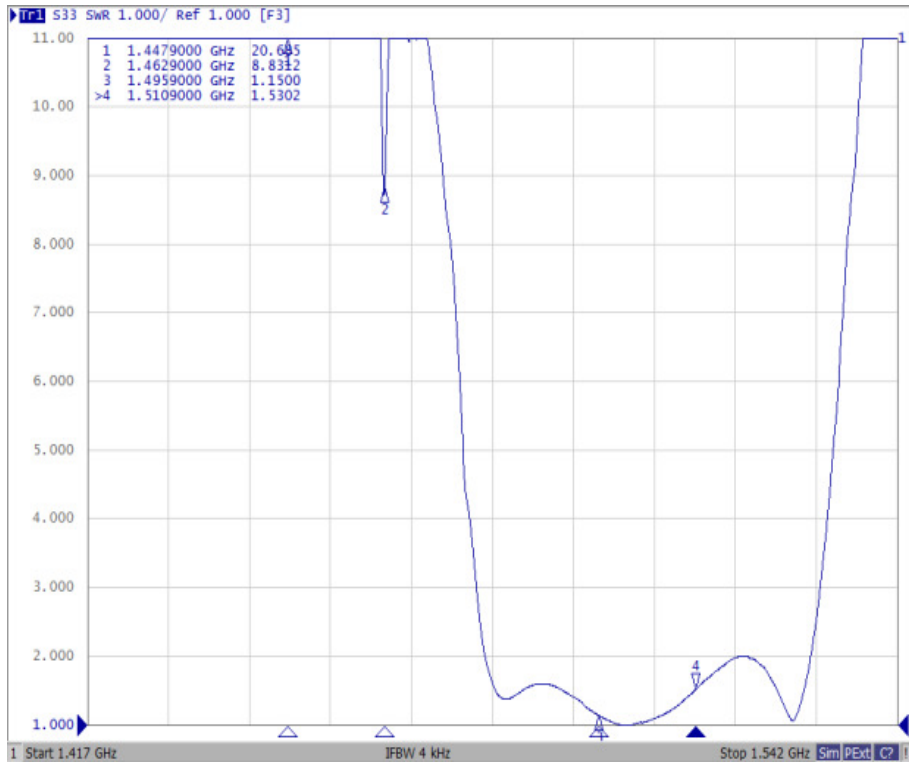

Ant Port

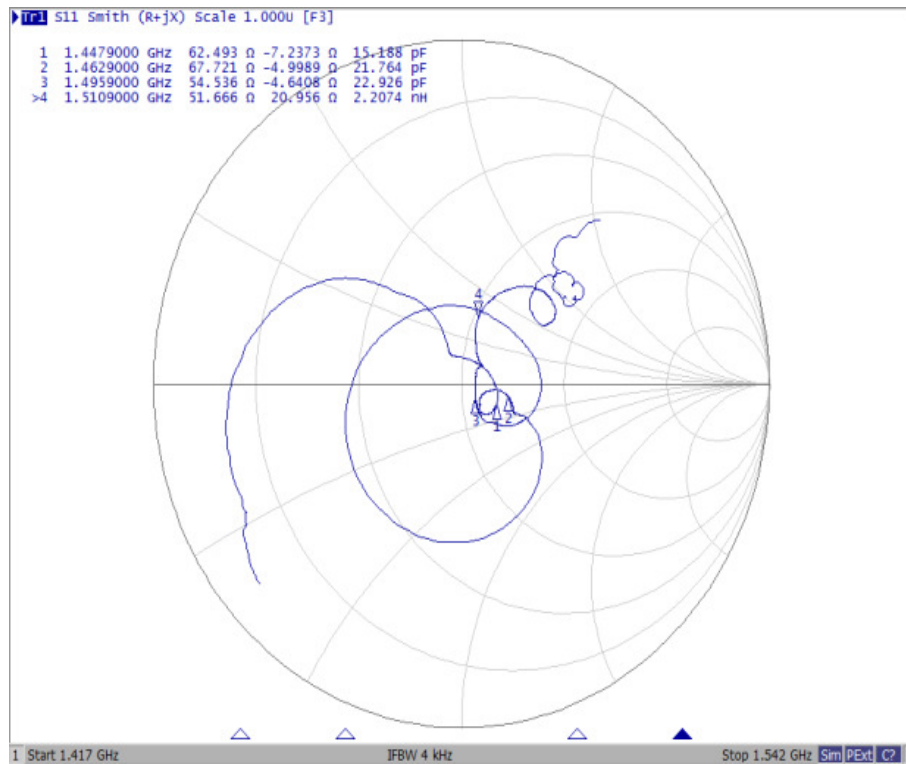
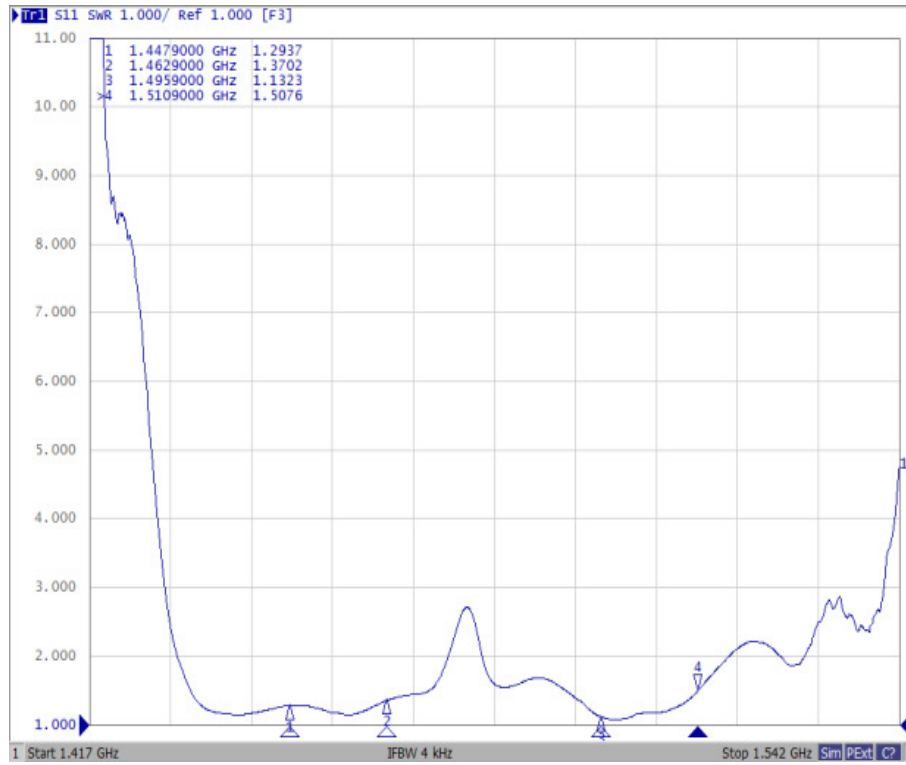

Tx to Ant (Wide span)

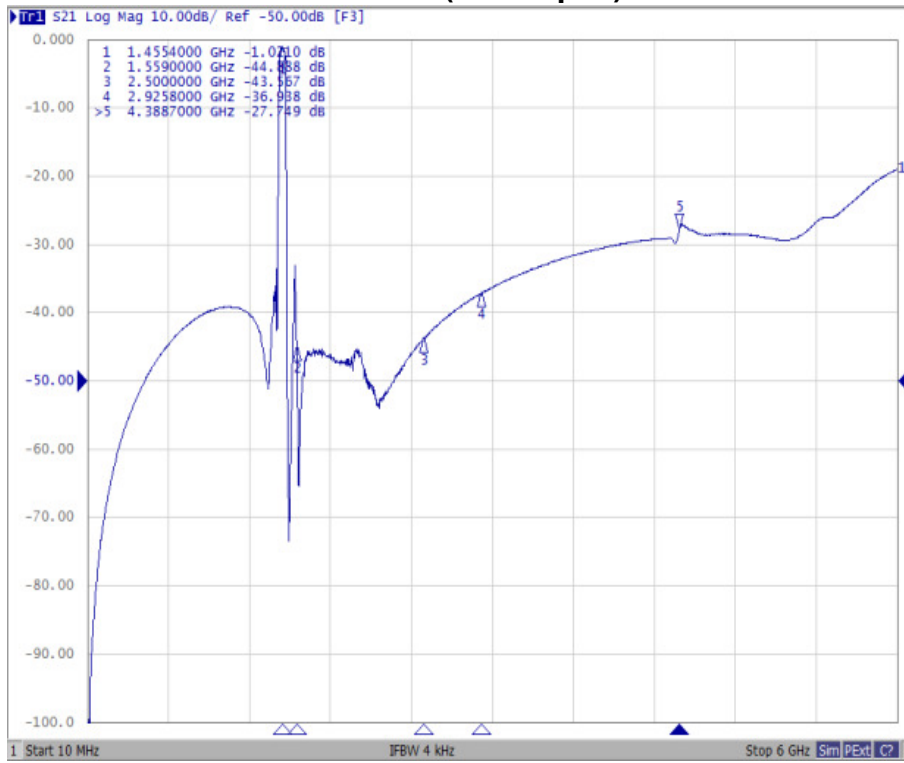

Ant to Rx (Wide span)

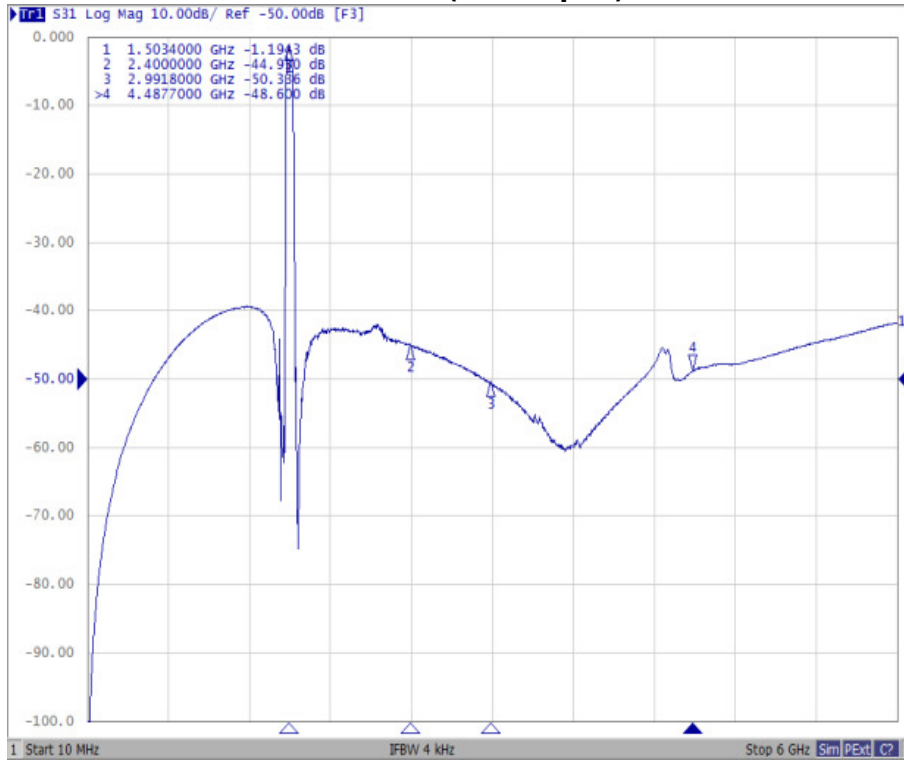

E. PCB FOOTPRINT:

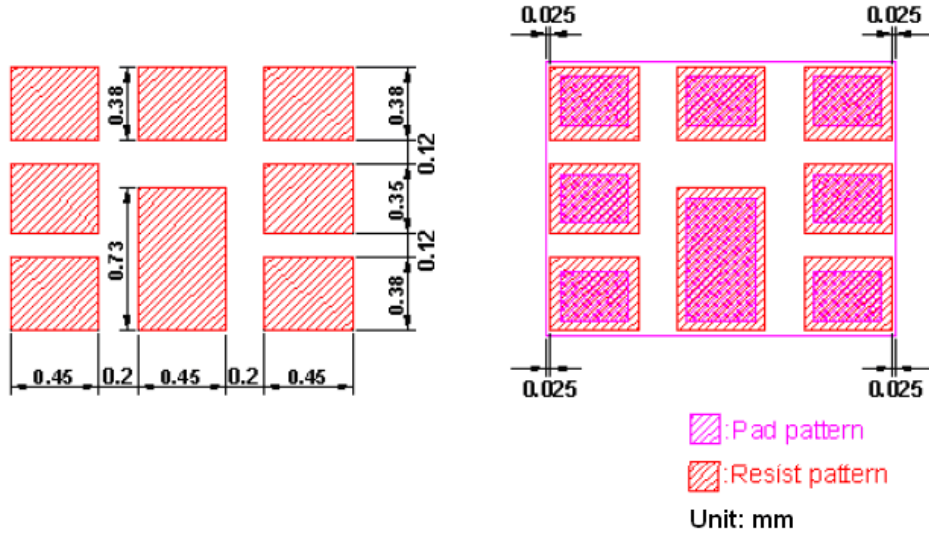

F. OUTLINE DRAWING:

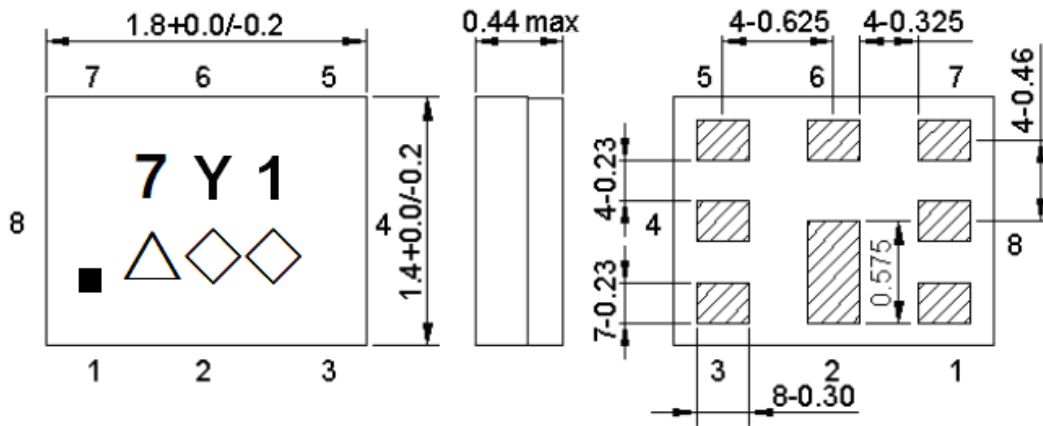

All tolerances are ± 0.1 mm unless otherwise specified.
Unit: mm

Marking name: 7Y1

△: Date Code (Follow below table)

◇◇: Lot No. (Indicated by 0~9 or A to Z and a to z, except I, O, i, o and l)

Date Code table:

Year	Jan.	Feb.	Mar.	Apr.	May	Jun.	Jul.	Aug.	Sep.	Oct.	Nov.	Dec.
2020	n	p	q	r	s	t	u	v	w	x	y	z
2021	A	B	C	Đ	E	F	G	H	J	K	L	M
2022	N	P	Q	R	S	T	U	V	W	X	Y	Z
2023	a	b	c	d	e	f	g	h	J	k	l	m

Pin Assignment

Pin No.	Pin name	Description
1	Rx	Receiver
2	GND	Ground
3	Tx	Transmitter
4	GND	Ground
5	GND	Ground
6	ANT	Antenna
7	GND	Ground
8	GND	Ground

G. PACKING: (Ref: WI-75M03)

1. REEL DIMENSION

(Please refer to FR-75D10 for packing quantity)

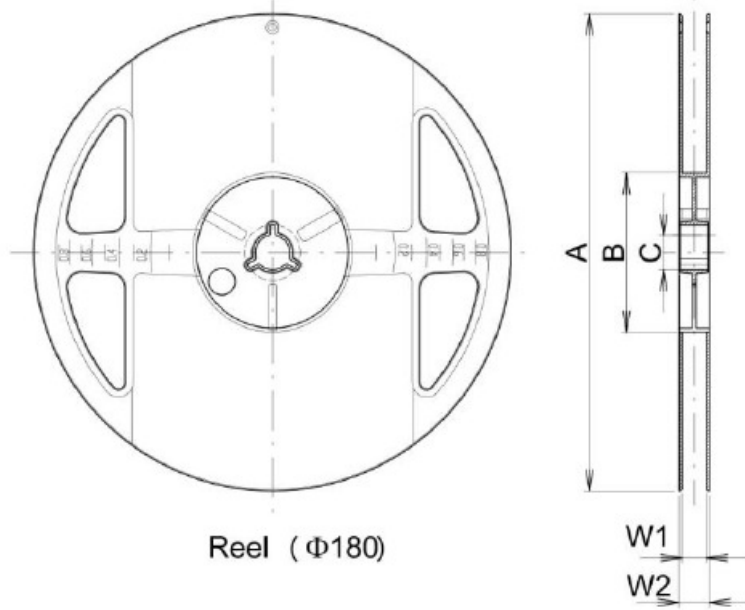

Reel (Φ180)

Unit : mm

A	B	C	W1	W2
180.0 +0.0/-1.5	60.0 +1.0/-0.0	13.0 ±0.2	9.0 +1.0/-0.0	11.4 ±1.0

2. TAPE DIMENSION

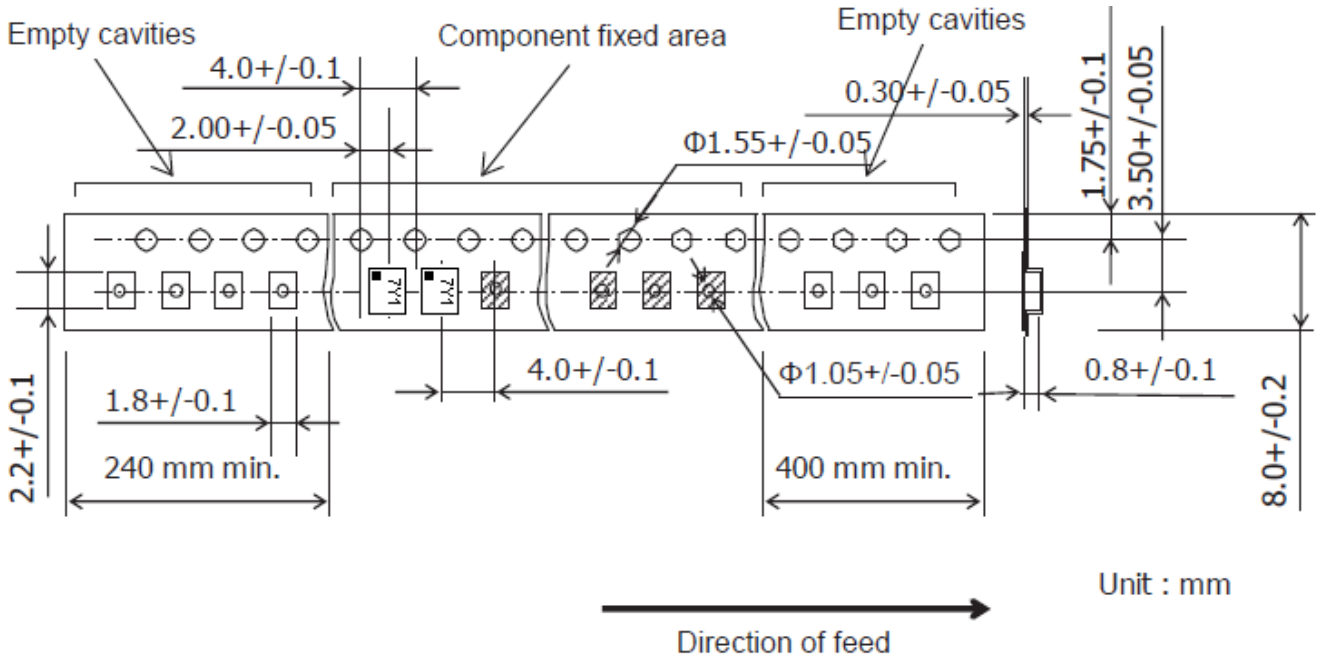

Unit : mm

H. RECOMMENDED REFLOW PROFILE:

1. Preheating shall be fixed at 150~180°C for 60~90 seconds.
2. Ascending time to preheating temperature 150°C shall be 30 seconds min.
3. Heating shall be fixed at 220°C for 50~80 seconds and at 260°C+0/-5°C peak (20~40sec).
4. Time: 2 times.

