



TAI-SAW TECHNOLOGY CO., LTD.

No. 3, Industrial 2nd Rd., Ping-Chen Industrial District,
Taoyuan, 324, Taiwan, R.O.C.

TEL: 886-3-4690038 FAX: 886-3-4697532

E-mail: tstsales@mail.taisaw.com Web: www.taisaw.com

Product Specifications Approval Sheet

Product Description: SAW DPX 897.5/942.5 MHz LTE Band 8 SMD 1.8X1.4 mm(BW=34.52MHz)

TST Part No.: TF0209B(This part is compliant with AEC-Q200)

Customer Part No.: _____

Customer signature required
Company: _____
Division: _____
Approved by : _____
Date: _____

Checked by: _____ Anne Chen *Anne Chen*

Approved by: _____ Andy Yu *Andy Yu*

Date: _____ 2020 . 02 . 20

1. Customer signed back is required before TST can proceed with sample build and receive orders.
2. Orders received without customer signed back will be regarded as agreement on the specifications.
3. Any specifications changes must be approved upon by both parties and a new revision of specifications shall be released to reflect the change



TAI-SAW TECHNOLOGY CO., LTD.

No. 3, Industrial 2nd Rd., Ping-Chen Industrial District,
Taoyuan, 324, Taiwan, R.O.C.

TEL: 886-3-4690038 FAX: 886-3-4697532

E-mail: tstsales@mail.taisaw.com Web: www.taisaw.com

SAW DPX 897.5/942.5 MHz Band 8 SMD 1.8X1.4 mm (BW=34.52 MHz)
MODEL NO.:TF0209B REV.1.0

A. MAXIMUM RATING:

1. Maximum DC Voltage: 5 V
2. Operating temperature range: -40 °C to +85 °C
3. Storage temperature range: -55 °C to +125 °C
4. Input power : 29dBm (Ta=+50°C,10000h,LTE 5MHz modulation)
5. Moisture Sensitivity Level: Level 3 (MSL 3)
- 6.ESD 100V(MM) 200V(HBM)

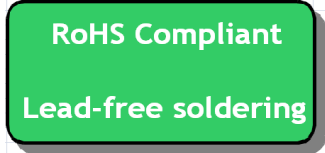

Electrostatic Sensitive Device (ESD)

B. ELECTRICAL CHARACTERISTICS:

Terminating impedance (Tx Port): 50//22nH Ω(Single-ended)

Terminating impedance (Rx Port): 50 Ω (Single-ended)

Terminating impedance (Ant Port): 50//8.2nH Ω (Single-ended)

Tx to ANT (f_{T0}=897.5 MHz)

Parameters Description		Unit	Min	Typ	Max	Remarks	
Insertion Loss	882.4~912.6MHz	dB(*2)	-	1.3	2.4	-20~+85°C	
	882.4~912.6MHz	dB(*2)		1.3	3.0	-40~+85°C	
	880.24~914.76MHz	dB	-	-	3.6	-30~ -20°C	
		dB	-	1.6	3.2	-20~+85°C	
		dB	-	1.6	3.8	-40~+85°C	
Amplitude ripple	880.24~914.76MHz	dB	-	1.0	3.2	-	
VSWR	ANT	880.24~914.76MHz	-	-	1.4	2.2	-
	Tx	880.24~914.76MHz	-	-	1.4	2.2	-
Attenuation:							
927.4 ~ 957.6 MHz		dB(*2)	48	54	-	-20~+85°C	
		dB(*2)	45	54		-40~+85°C	
925.24 ~ 959.76 MHz		dB	37	-	-	-30~ -20°C	
		dB	42	-	-	-20~ 0°C	
		dB	42	54	-	-40~+85°C	
1565 ~ 1606 MHz		dB	40	43	-		
1760 ~ 1830 MHz		dB	40	48	-		
2640 ~ 2745 MHz		dB	28	37	-		

(*1)Specification of insertion loss excludes loss that comes from the test board.

(*2)Integrated over +/-1.92MHz around the WCDMA channel center frequency.

ANT to Rx ($f_{T0}=942.5$ MHz)

Parameters Description		Unit	Min	Typ	Max	Remarks
InsertionLoss(*1)	927.4~957.6 MHz	dB(*2)	-	1.5	2.5	-20~+85°C
		dB(*2)		1.5	3.2	-40~+85°C
InsertionLoss(*1)	925.24~959.76 MHz	dB	-	-	3.5	-30~ -20°C
		dB	-	1.8	3.6	-40~+85°C
Amplitude ripple		dB	-	1.1	2.9	
VSWR	ANT	-	-	1.8	2.2	
	Rx	-	-	1.7	2.2	
Attenuation:						
880.24 ~ 914.76 MHz		dB	45	54	-	
1805 ~ 1875 MHz		dB	40	52	-	
2400 ~ 2500 MHz		dB	40	49	-	
2685 ~ 2790 MHz		dB	40	48	-	

(*1) Specification of insertion loss excludes loss that comes from the test board.

(*2) Integrated over +/-1.92MHz around the WCDMA channel center frequency.

Tx to Rx

Isolation	882.4~912.6MHz	dB(*2)	55	58	-	-20~+85°C
			50	58	-	-40~+85°C
	880.24~914.76 MHz	dB	48	-	-	
			55	58	-	-30~ +25°C
	927.4~957.6MHz	dB(*2)	55	58	-	-20~+85°C
			50	58	-	-40~+85°C
	925.24~959.76 MHz	dB	40	-	-	-40~ -20°C
			45	-	-	-20~ 0°C
			53	56	-	0~ +85°C

(*2) Integrated over +/-1.92MHz around the WCDMA channel center frequency

C.Evaluation Circuit

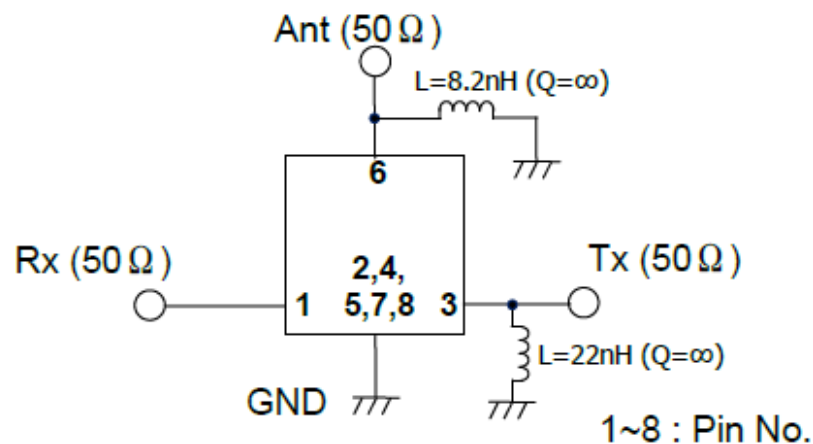

D. FREQUENCY CHARACTERISTICS:

Tx to Ant

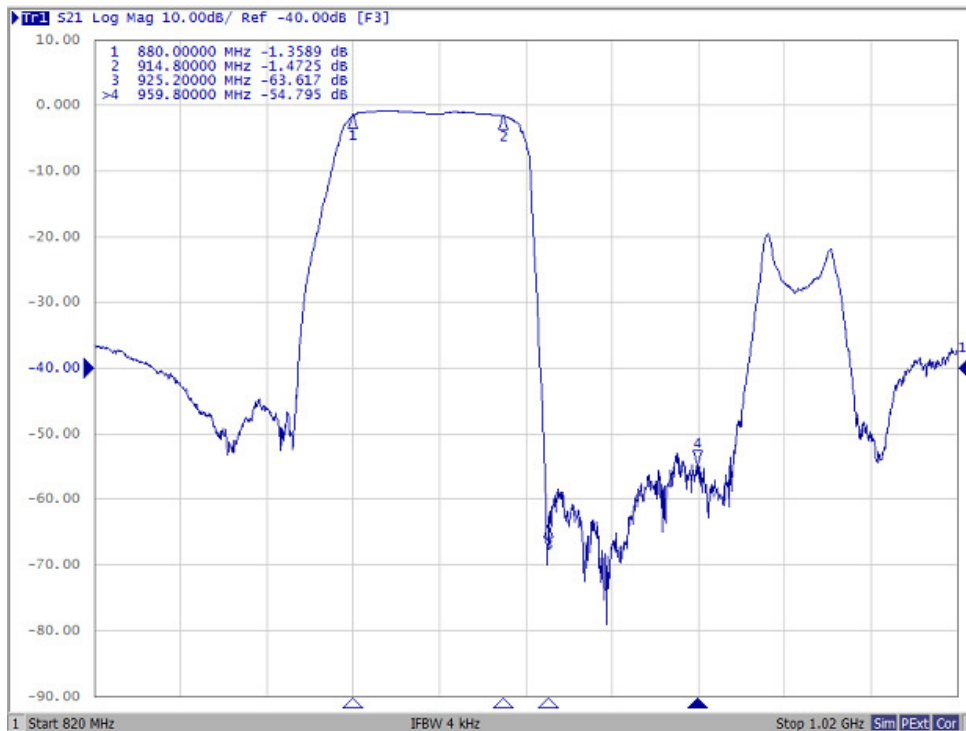

Ant to Rx

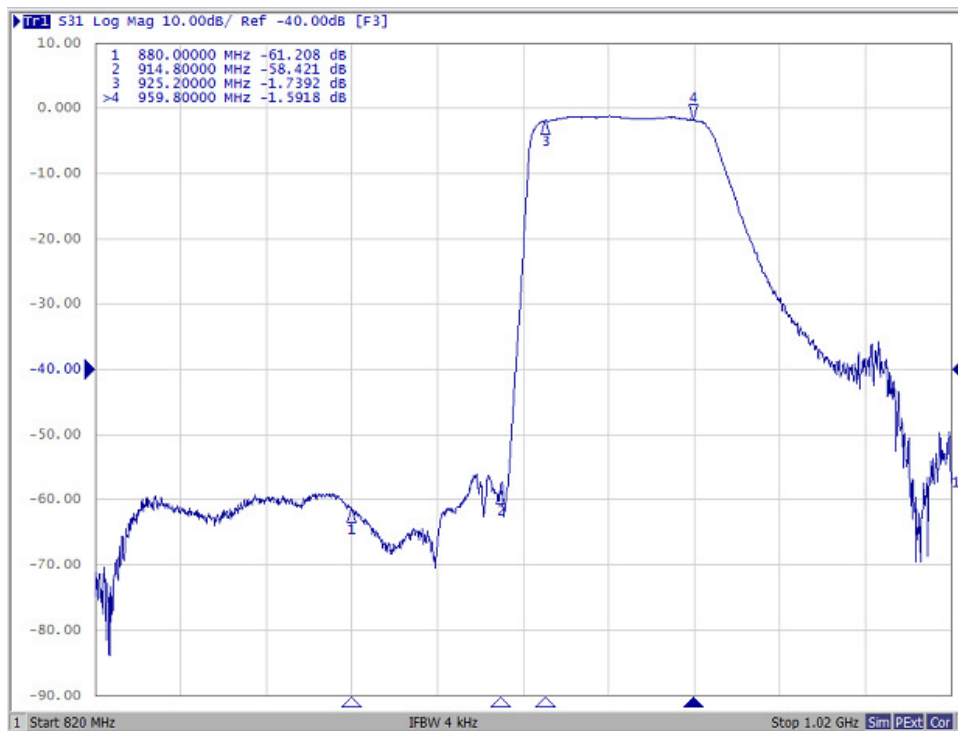

Tx to Ant ,Ant to Rx

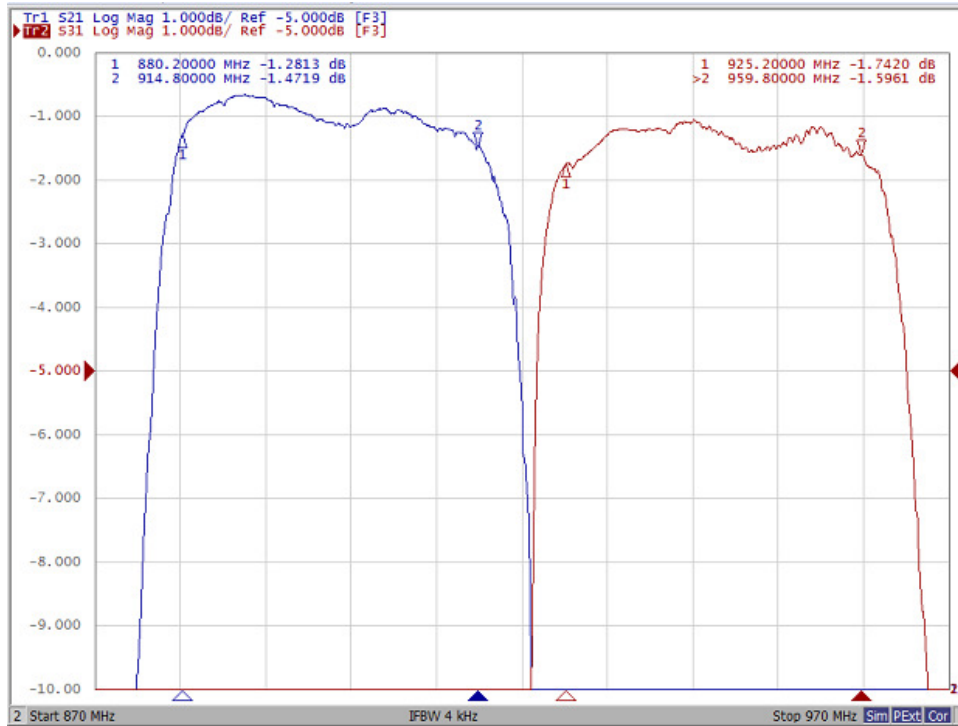

Tx to Rx Isolation

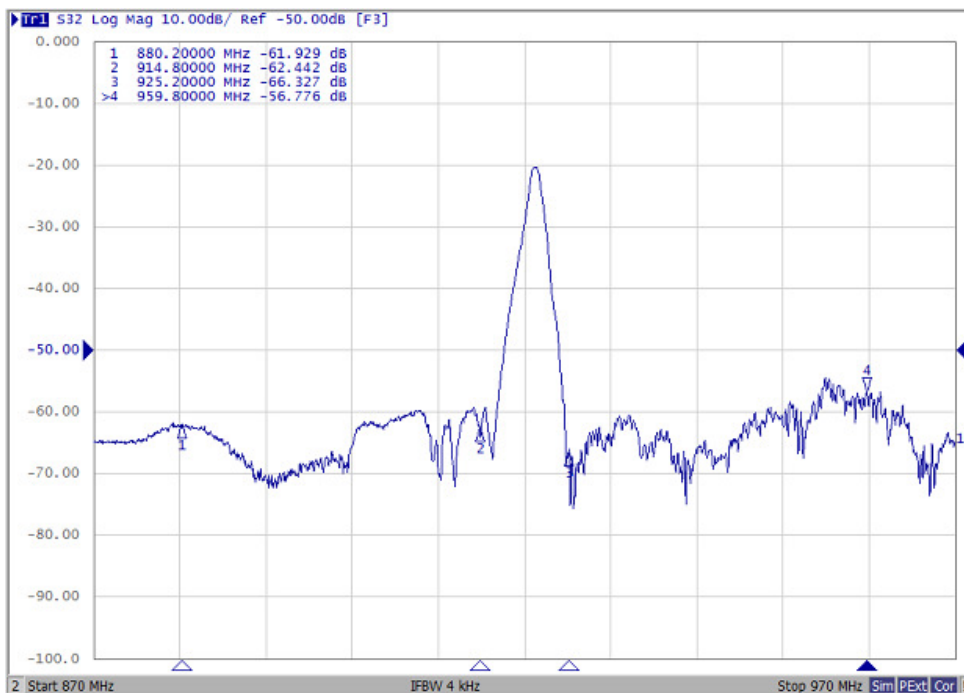

Tx Port

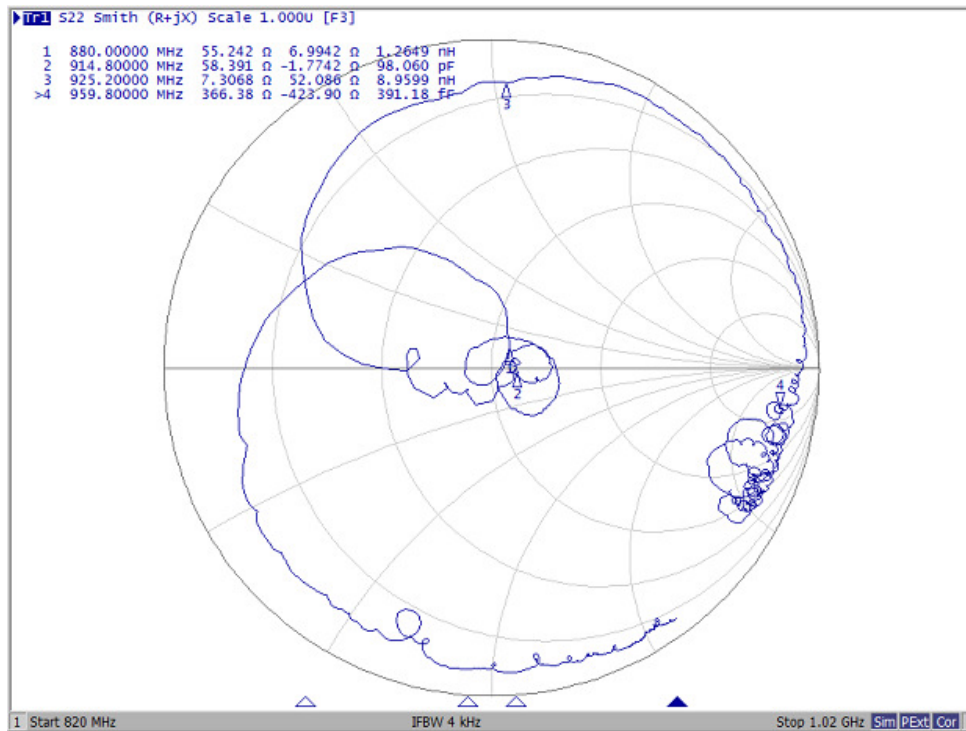
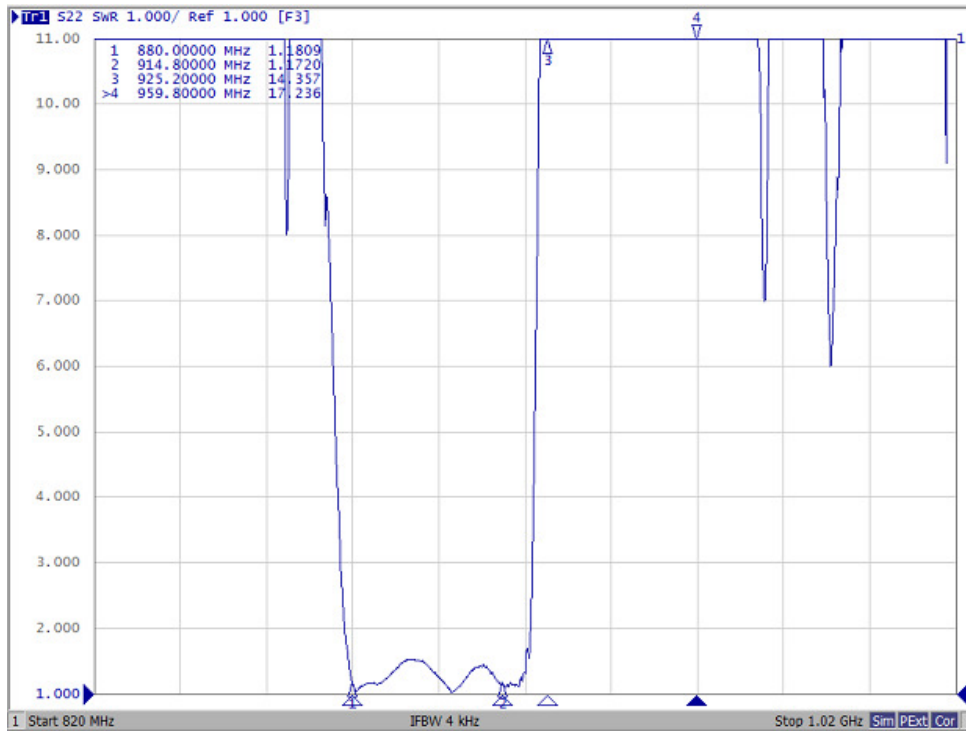

Rx Port

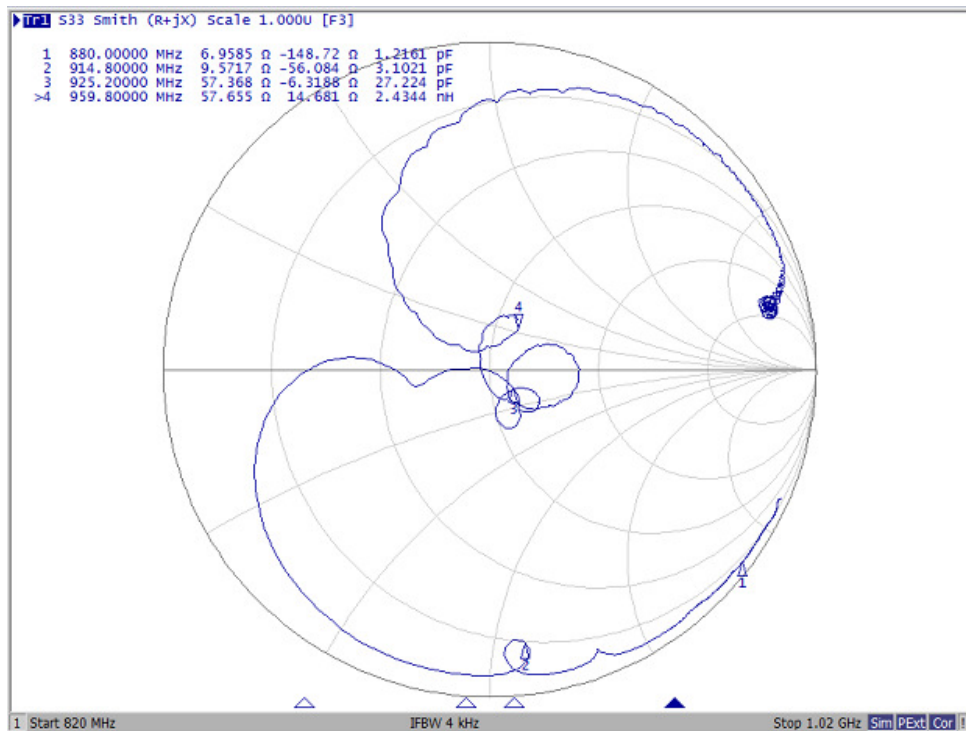
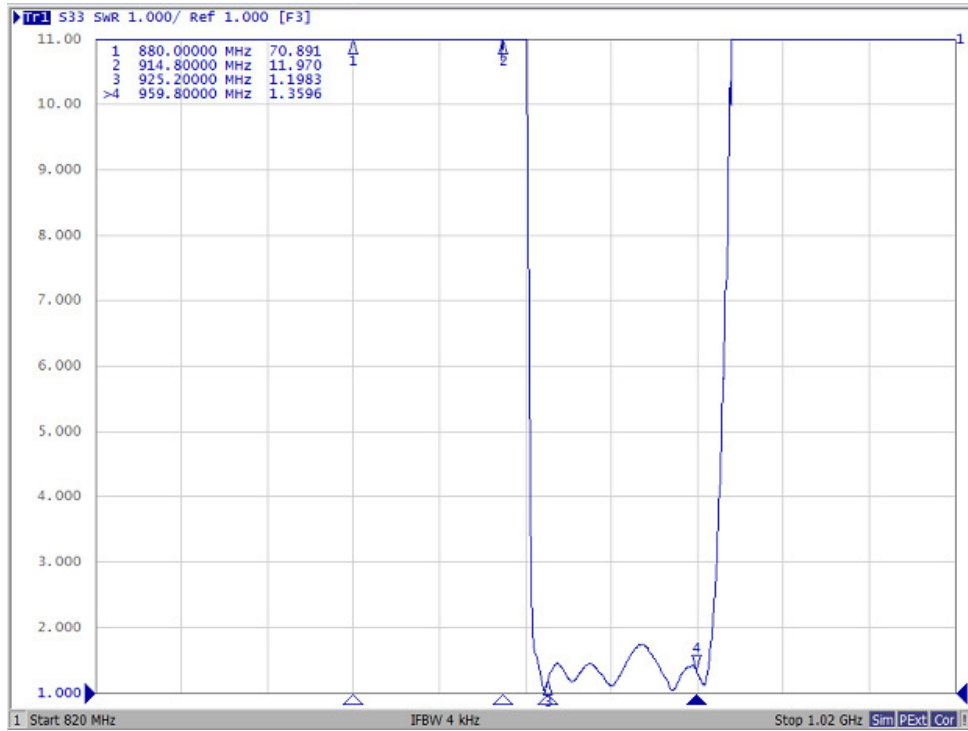

Ant Port

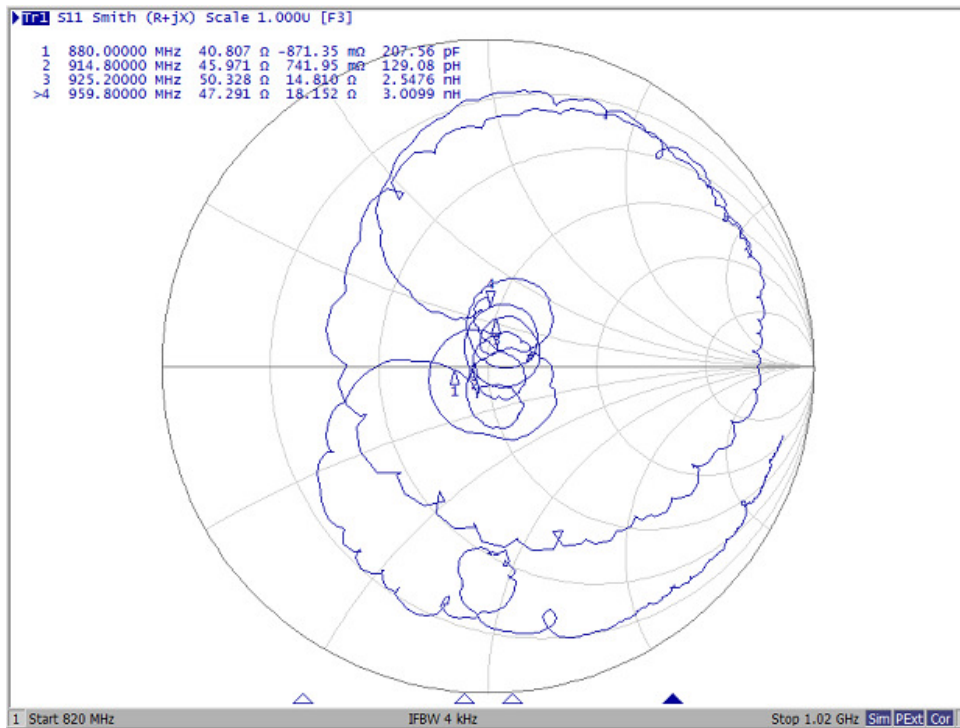
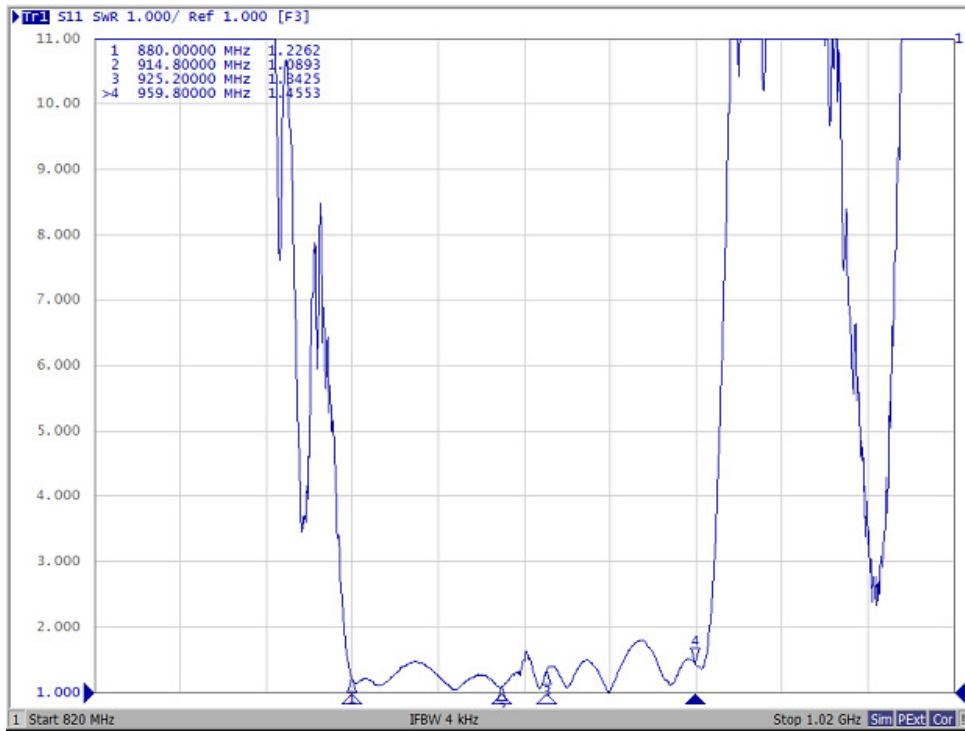

Tx to Ant (Wide span)

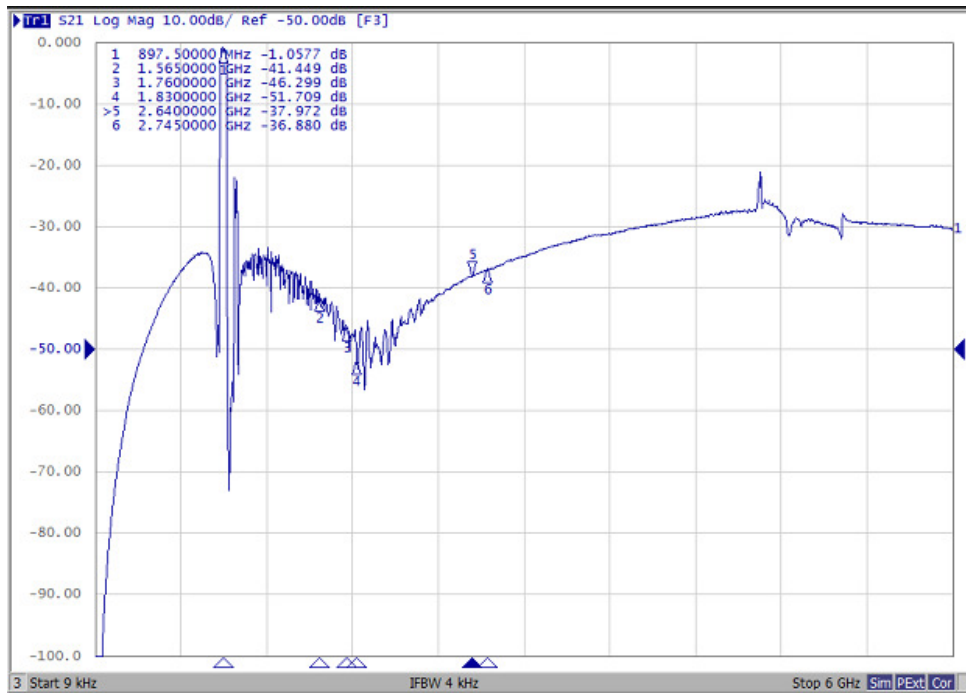

Ant to Rx (Wide span)

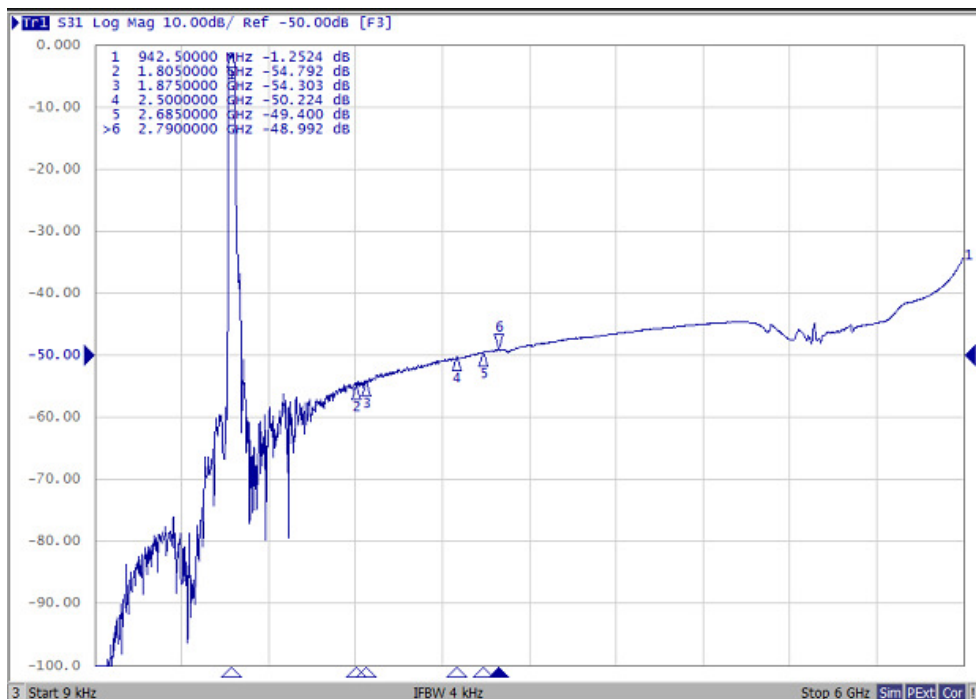

E. OUTLINE DRAWIN:

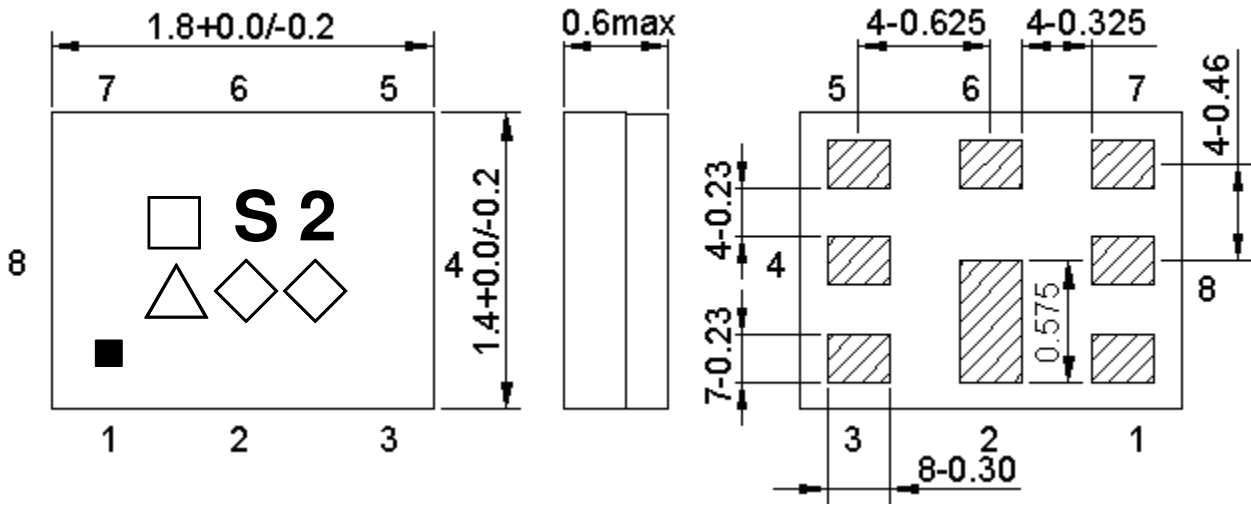

Not Specified Tolerance : +/-0.1 mm
Unit : mm

Traceability code (□ : S or 7)

Marking name : **7S2**

△: Date code(2020 May → s ,....., 2023 Dec→m.)

◇◇: Lot Code.

Product Date Code. Follow below table. (4-year cycle)

Year	Jan	Feb	Mar	Apr	May	Jun	Jul	Aug	Sep	Oct	Nov	Dec
2020	n	p	q	r	s	t	u	v	w	x	y	z
2021	A	B	C	D	E	F	G	H	J	K	L	M
2022	N	P	Q	R	S	T	U	V	W	X	Y	Z
2023	a	b	c	d	e	f	g	h	j	k	l	m

Pin Configuration

Pin No.	Pin name	Description
1	Rx	Receiver Pin
2	GND	Ground Pin
3	Tx	Transmitter Pin
4	GND	Ground Pin
5	GND	Ground Pin
6	ANT	Antenna Pin
7	GND	Ground Pin
8	GND	Ground Pin

Figure 1. Dimensions and Pin assignment

F. FOOTPRINT:

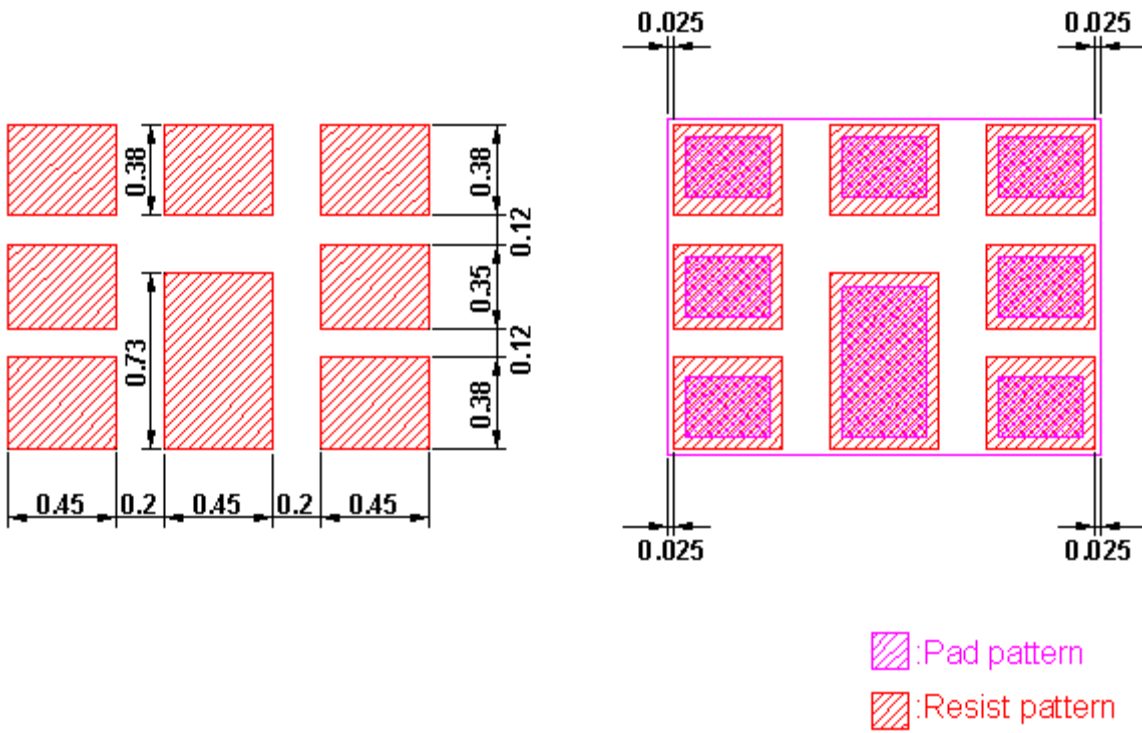

G. PACKING:

1. REEL DIMENSION

(Please refer to FR-75D10 for packing quantity)

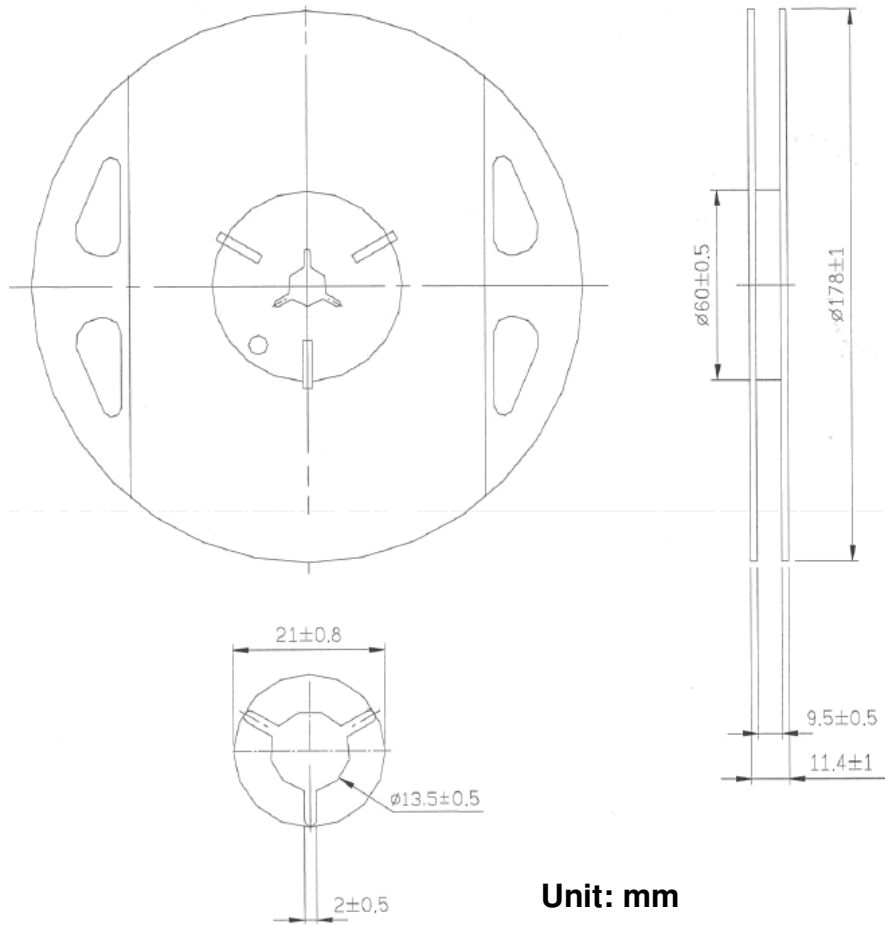

Unit: mm

2. TAPE DIMENSION

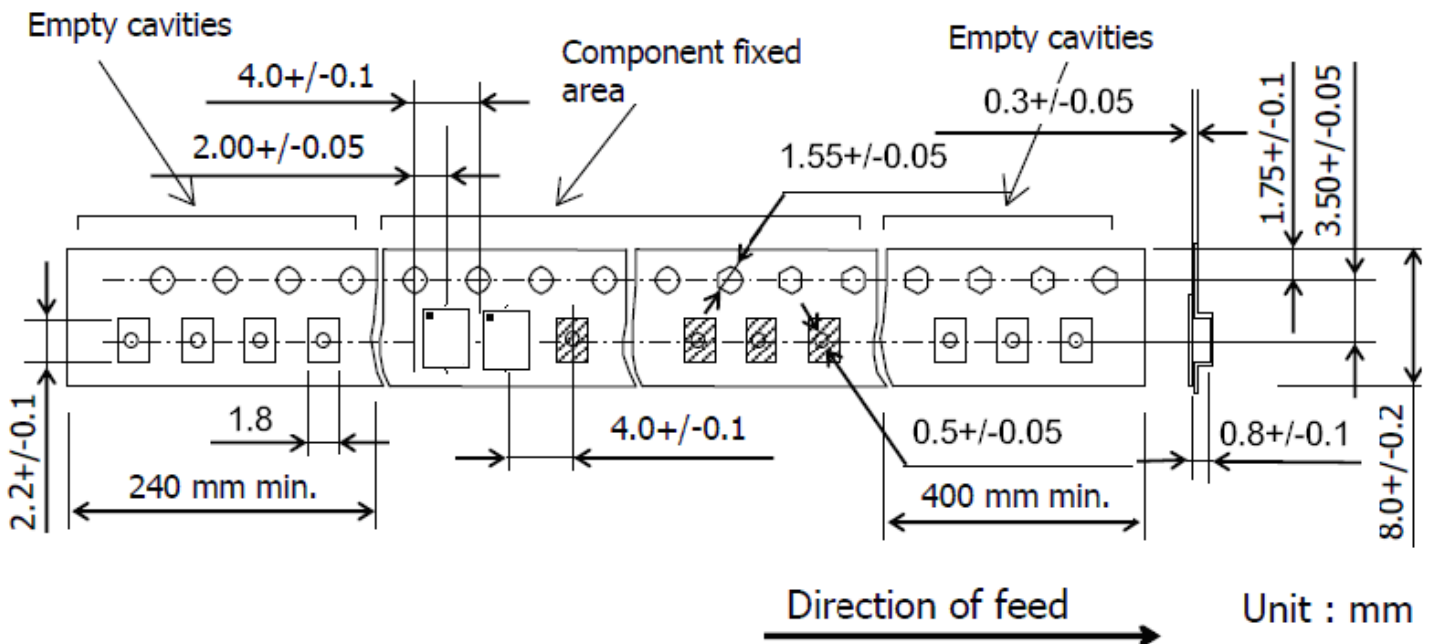

Unit : mm

H. RECOMMENDED REFLOW PROFILE :

1. Preheating shall be fixed at 150~180°C for 60~90 seconds.
2. Ascending time to preheating temperature 150°C shall be 30 seconds min.
3. Heating shall be fixed at 220°C for 50~80 seconds and at 245~260°C peak (min. 10sec).
4. Time : 2 times.

