



TAI-SAW TECHNOLOGY CO., LTD.

No. 3, Industrial 2nd Rd., Ping-Chen Industrial District,
Taoyuan, 324, Taiwan, R.O.C.
TEL: 886-3-4690038 FAX: 886-3-4697532
E-mail: tstsales@mail.taisaw.com Web: www.taisaw.com

Product Specifications Approval Sheet

Product Description: LTCC Filter 5887.5 MHz SMD 2.5x2.0 mm (75MHz BW)

TST Part No.: TL0032B(AEC-Q200)

Customer Part No.: _____

Customer signature required
Company: _____
Division: _____
Approved by : _____
Date: _____

Checked by: _____ Hongpu Lin

Approved by: _____ Andy Yu

Date: _____ 2019/10/01

1. Customer signed back is required before TST can proceed with sample build and receive orders.
2. Orders received without customer signed back will be regarded as agreement on the specifications.
3. Any specifications changes must be approved upon by both parties and a new revision of specifications shall be released to reflect the change



TAI-SAW TECHNOLOGY CO., LTD.

No. 3, Industrial 2nd Rd., Ping-Chen Industrial District,
Taoyuan, 324, Taiwan, R.O.C.

TEL: 886-3-4690038 FAX: 886-3-4697532

E-mail: tstsales@mail.taisaw.com Web: www.taisaw.com

LTCC Filter 5887.5 MHz SMD 2.5X2.0 mm (75 MHz BW)

MODEL NO.: TL0032B

REV.1

A. MAXIMUM RATING:

1. Input power: 1W
2. Operating temperature range: -40 °C to +85 °C
3. Storage temperature range: -40 °C to +85 °C
4. Moisture Sensitive Level: Level 1 (MSL1)

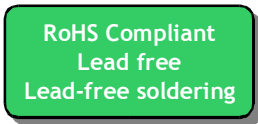

Electrostatic Sensitive Device (ESD)

B. ELECTRICAL CHARACTERISTICS:

Item	Unit	Min	Typ	Max	
Center Frequency	MHz	5850	5887.5	5925	
Insertion Loss (5850 ~ 5925) 25°C IL	dB	1.6	1.86	2.2	
Band Width 5850 ~ 5925	MHz	75	80	90	
Return Loss (in BW)	dB	10	14	30	
Attenuation (dB)	1908 ~ 1950 MHz	dB	50	62	70
	3816 ~ 3900 MHz	dB	47	52	83
	11450 ~ 11700 MHz	dB	25	36	45
In/Output Impedance	Ω	50			
Input power (max.)	1W				

C. FREQUENCY CHARACTERISTICS:

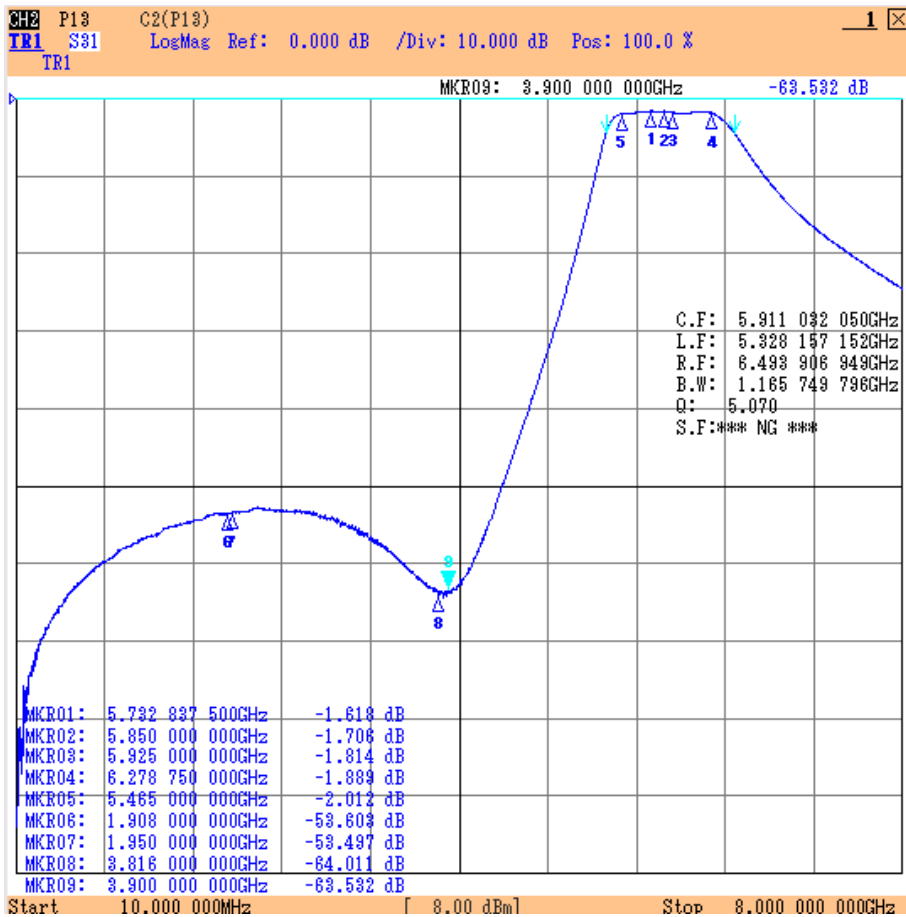
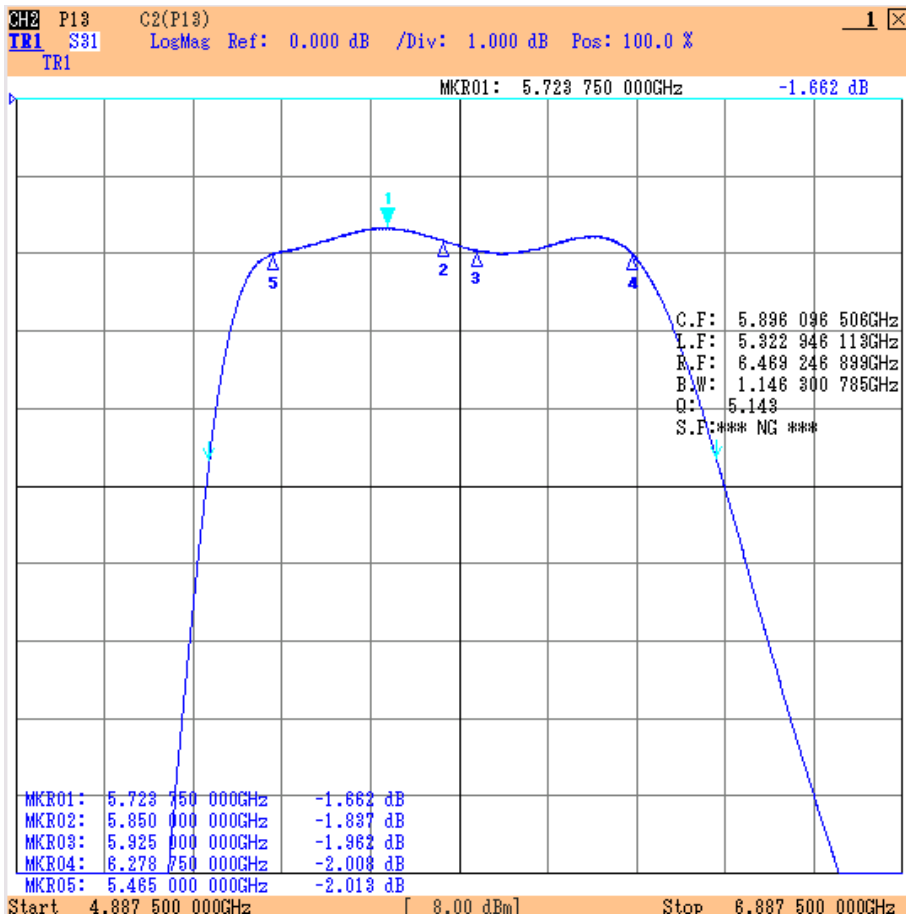

D. DIMENSIONS: (Unit: mm)

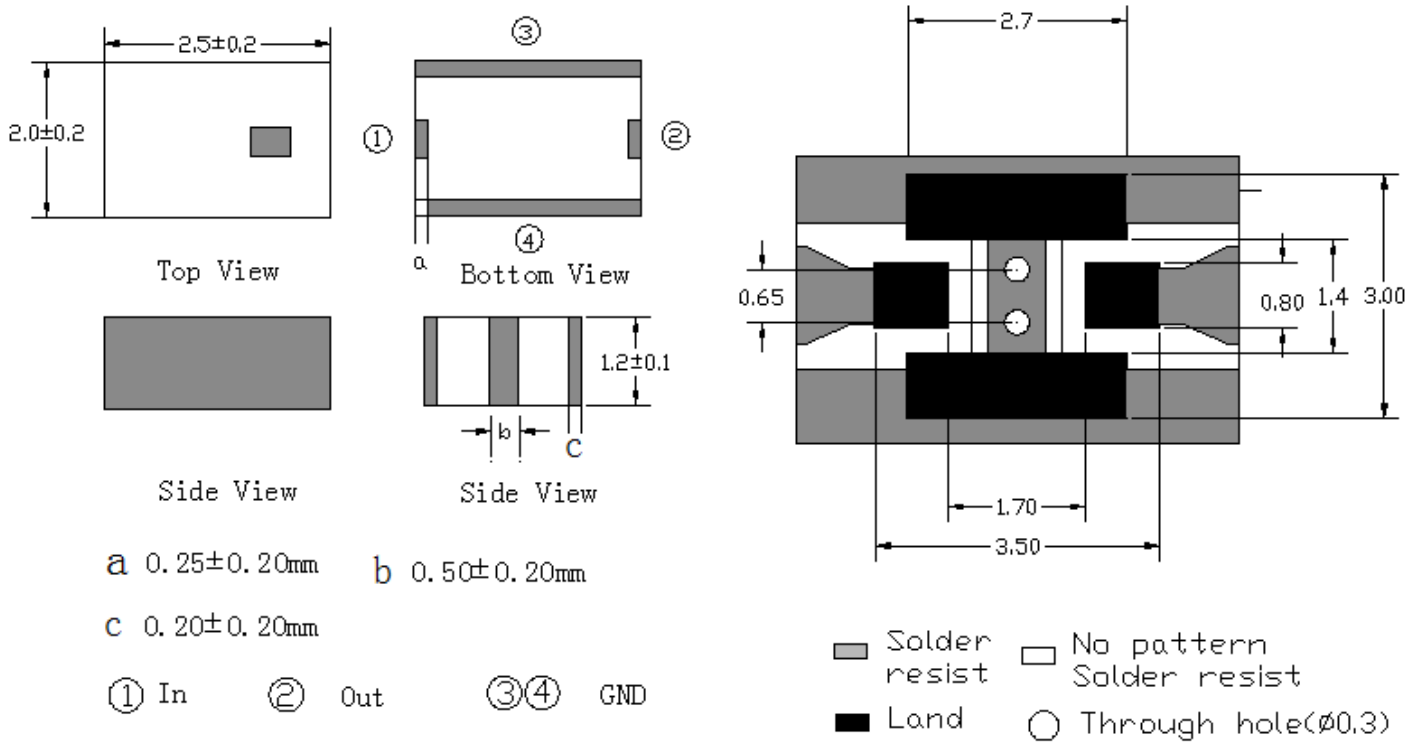

※Line width should be designed to match 50Ω characteristic impedance, depending on PCB material and thickness.

E. PACKING:

1. REEL DIMENSION (2500 PCS/Reel)

(Please refer to FR-75D10 for packing quantity)

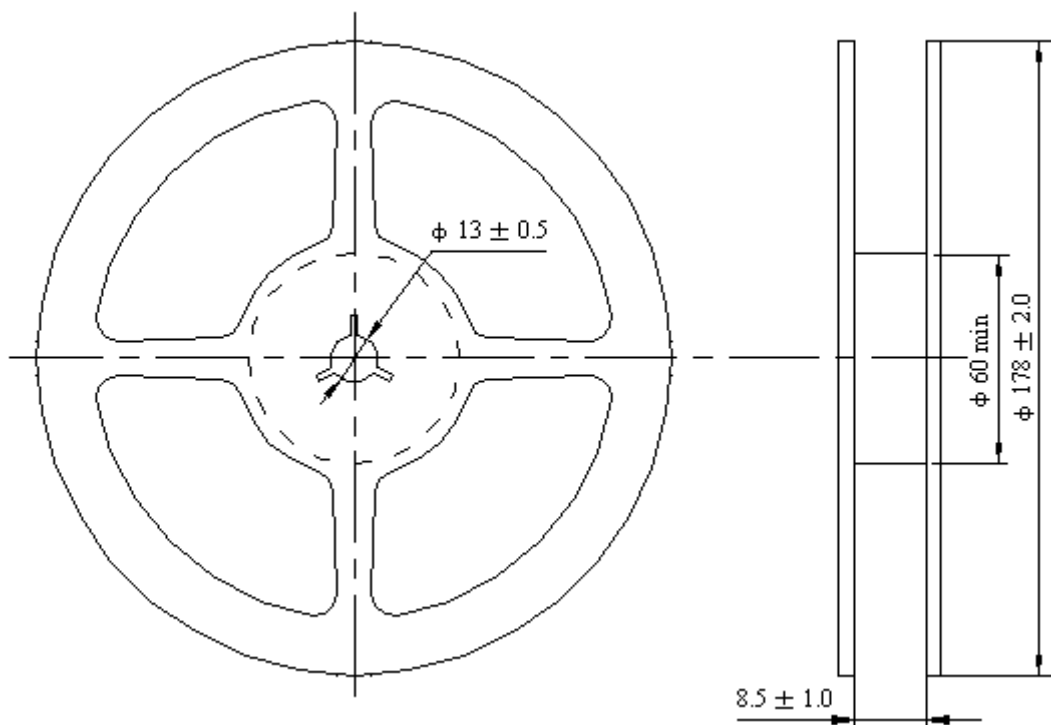

2. TAPE

DIMENSION (Unit: mm)

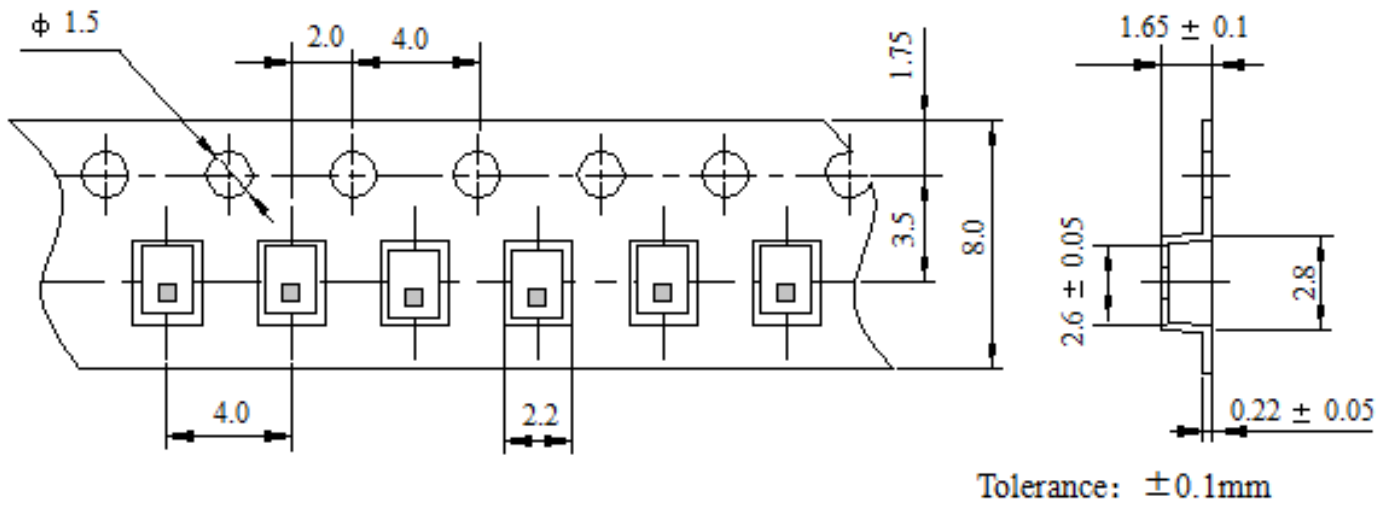

F. RECOMMENDED REFLOW PROFILE:

