



# TAI-SAW TECHNOLOGY CO., LTD.

No. 3, Industrial 2nd Rd., Ping-Chen Industrial District,  
Taoyuan, 324, Taiwan, R.O.C.

TEL: 886-3-4690038 FAX: 886-3-4697532

E-mail: [tstsales@mail.taisaw.com](mailto:tstsales@mail.taisaw.com) Web: [www.taisaw.com](http://www.taisaw.com)

## Product Specifications Approval Sheet

Product Description: LTCC Filter 4700 MHz Size 2.0x1.25 mm

TST Part No.: TL0038A

Customer Part No.: \_\_\_\_\_

Customer signature required
Company: _____
Division: _____
Approved by : _____
Date: _____

Checked by: \_\_\_\_\_ Nina Chen *Nina Chen*

Approved by: \_\_\_\_\_ Kazuma Lee *Kazuma Lee*

Date: \_\_\_\_\_ 2022/10/07

1. Customer signed back is required before TST can proceed with sample build and receive orders.
2. Orders received without customer signed back will be regarded as agreement on the specifications.
3. Any specifications changes must be approved upon by both parties and a new revision of specifications shall be released to reflect the change



# TAI-SAW TECHNOLOGY CO., LTD.

No. 3, Industrial 2nd Rd., Ping-Chen Industrial District,

Taoyuan, 324, Taiwan, R.O.C.

TEL: 886-3-4690038 FAX: 886-3-4697532

E-mail: [tstsales@mail.taisaw.com](mailto:tstsales@mail.taisaw.com) Web: [www.taisaw.com](http://www.taisaw.com)

## LTCC Filter 4700 MHz SMD 2.0X1.25 mm

MODEL NO.: TL0038A

REV.2

### A. MAXIMUM RATING:

1. Operating temperature range: -40°C to +85°C
2. Storage temperature range: -40 °C to +85 °C
3. Impedance (Unbalanced) : 50Ω
4. Moisture Sensitive Level: Level 1 (MSL1)

RoHS Compliant  
Lead-free soldering

Electrostatic Sensitive Device (ESD)

### B. ELECTRICAL CHARACTERISTICS:

Item	Specifications
Frequency range	4400 ~ 5000 MHz
Insertion Loss (at 25°C)	2.00 dB max. @4400 ~ 4600 MHz 1.60 dB max. @4600 ~ 4800 MHz 1.80 dB max. @4800 ~ 5000 MHz
Insertion Loss (at -40 ~ +85°C)	2.30 dB max. @4400 ~ 4600 MHz 1.80 dB max. @4600 ~ 4800 MHz 2.30 dB max. @4800 ~ 5000 MHz
Attenuation	37 dB Min. @ 450 ~ 2200 MHz 37 dB Min. @ 2300 ~ 2483 MHz 33 dB Min. @ 2496 ~ 2690 MHz 15 dB Min. @ 5490 ~ 5670 MHz 25 dB Min. @ 5670 ~ 5950 MHz 25 dB Min. @ 6200 ~ 8000 MHz 25 dB Min. @ 8800 ~ 10000 MHz 15 dB Min. @ 13200 ~ 15000 MHz 15 dB Min. @ 17600 ~ 20000 MHz
VSWR	2.0 Max.
Characteristics Impedance	50Ω
Power Capacity	2W max.
Moisture sensitivity levels	MSL is LEVEL 1
<b>Operating &amp; Storage Condition (Component)</b> Operation Temperature Range: -40 ~ +85 °C. Storage Temperature Range: -40 ~ +85°C.	
<b>Storage Condition before Soldering (Included packaging material)</b> Storage Temperature Range: +5 ~ +40 °C. Humidity: 30 to 70% relative humidity	

**C. FREQUENCY CHARACTERISTICS:**

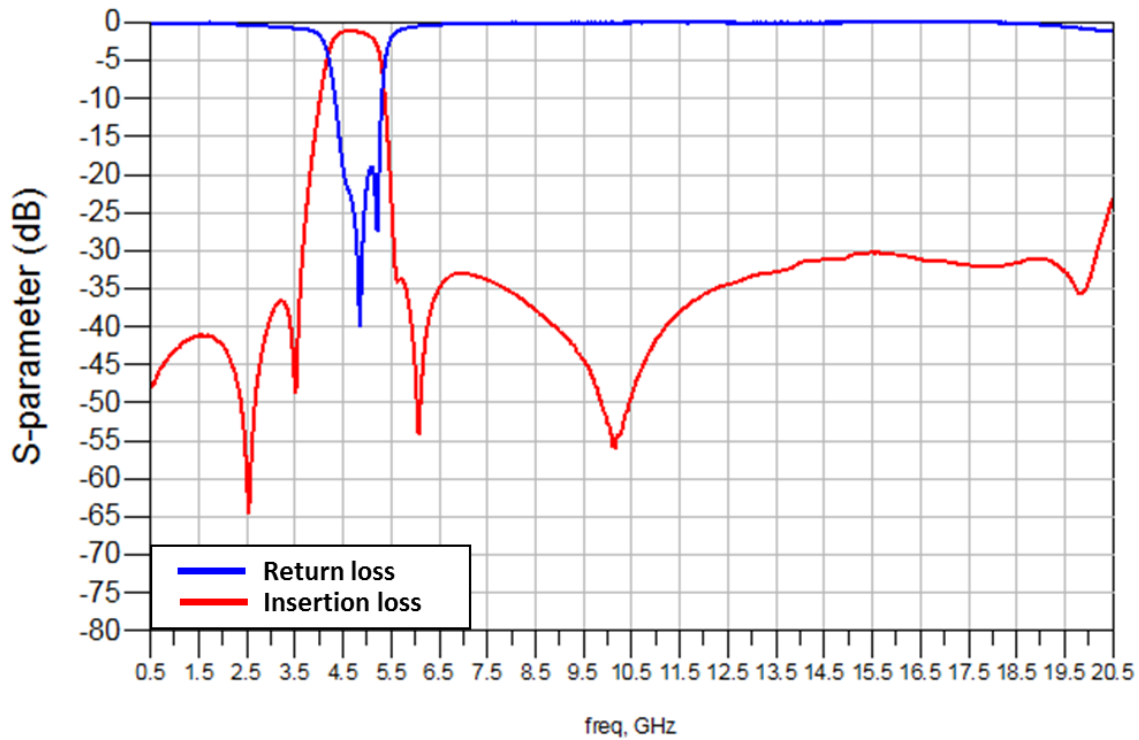

**D. OUTLINE DRAWING:**

Figure	Symbol	Dimension (mm)
Top view	L	$2.00 \pm 0.15$
	W	$1.25 \pm 0.15$
Bottom view	T	0.70 max.
	A	$0.95 \pm 0.10$
Side view	B	$0.275 \pm 0.10$
	C	$0.25 \pm 0.10$
	D	$0.60 \pm 0.10$
	E	$0.175 \pm 0.10$
	F	$0.15 \pm 0.10$

**E. CONSTRUCTION:**

Top view

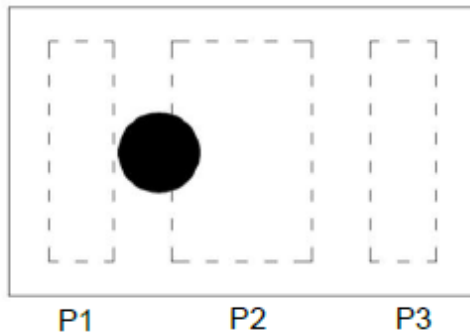

PIN	Connection
1	Input
2	GND
3	Output

**F. PCB FOOT PRINT:**

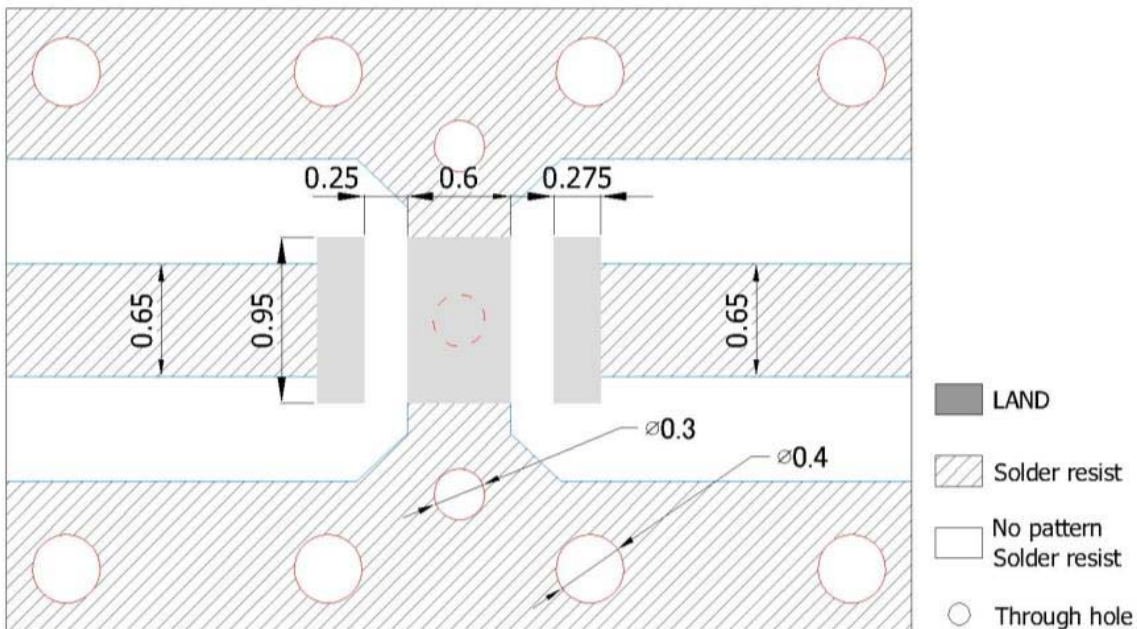

Unit: mm

Line width to be designed to match 50Ω characteristic impedance, depending on PCB material and thickness.

**G. PACKING:**

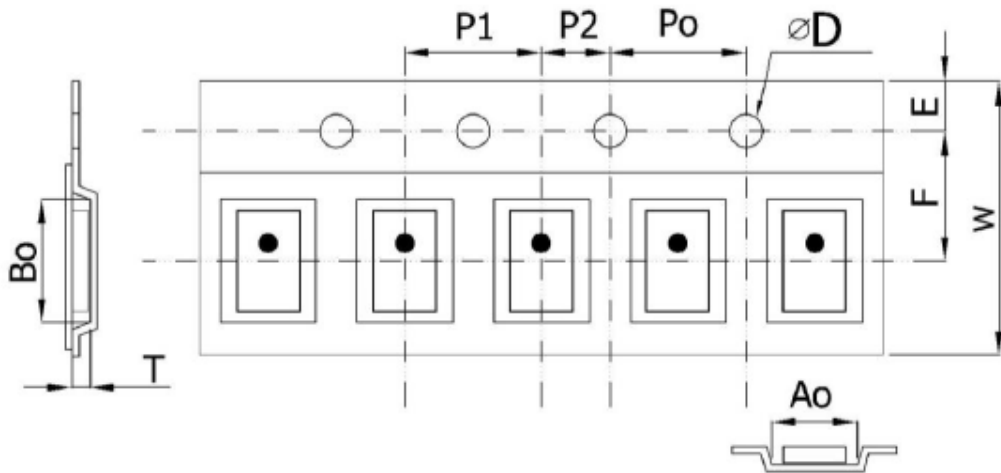

**Plastic Tape specifications (unit :mm)**

Index	Ao	Bo	ΦD	T	W
Dimension (mm)	1.40 ± 0.10	2.25 ± 0.10	1.55 ± 0.05	0.75 ± 0.10	8.00 ± 0.10
Index	E	F	Po	P1	P2
Dimension (mm)	1.75 ± 0.10	3.50 ± 0.05	4.00 ± 0.10	4.00 ± 0.10	2.00 ± 0.05

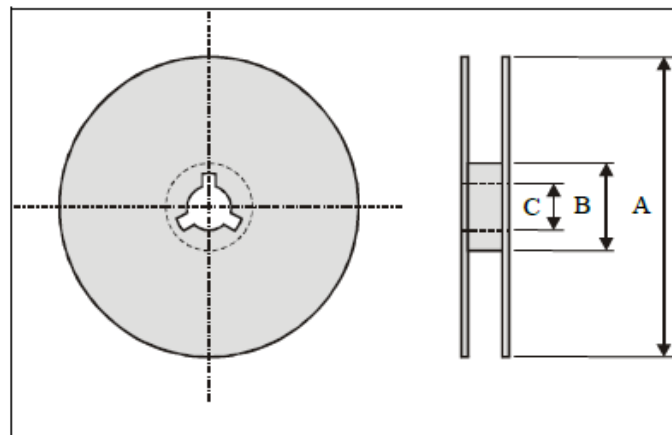

Index	A	B	C
Dimension (mm)	Φ178.0	Φ60.0	Φ13.0

Taping Quantity:2000 pieces per 7" reel

## H. RECOMMENDED REFLOW PROFILE:

1. Preheating shall be fixed at 150~180°C for 60~90 seconds.
2. Ascending time to preheating temperature 150°C shall be 30 seconds min.
3. Heating shall be fixed at 220°C for 50~80 seconds and at 260°C +0/-5°C peak (20~40sec).
4. Time: 2 times.

