



TAI-SAW TECHNOLOGY CO., LTD.

No. 3, Industrial 2nd Rd., Ping-Chen Industrial District,
Taoyuan, 324, Taiwan, R.O.C.

TEL: 886-3-4690038 FAX: 886-3-4697532

E-mail: tstsales@mail.taisaw.com Web: www.taisaw.com

Product Specifications Approval Sheet

Product Description: Print Chip Antenna 1582MHz BW 15MHz Size 25x25 mm
TST Parts No.: TQ0207AA0000

Customer Parts No.: _____

Customer signature required
Company: _____
Division: _____
Approved by : _____
Date: _____

Checked by: _____ Nina Chen *Nina Chen*

Approved by: _____ Kazuma Lee *Kazuma Lee*

Date: _____ 2023/07/07

1. Customer signed back is required before TST can proceed with sample build and receive orders.
2. Orders received without customer signed back will be regarded as agreement on the specifications.
3. Any specifications changes must be approved upon by both parties and a new revision of specifications shall be released to reflect the changes.



TAI-SAW TECHNOLOGY CO., LTD.

No. 3, Industrial 2nd Rd., Ping-Chen Industrial District,
Taoyuan, 324, Taiwan, R.O.C.

TEL: 886-3-4690038 FAX: 886-3-4697532

E-mail: tstsales@mail.taisaw.com Web: www.taisaw.com

Print Chip Antenna 1582MHz BW 15MHz Size 25x25 mm

MODEL NO.: TQ0207AA0000

REV. NO.:1.0

A. Maximum Rating:

1. Operating Temperature Range: -40°C to +105°C
2. Storage Temperature Range: 0°C to +40°C
3. Moisture Sensitivity Level: Level 1 (MSL 1)

RoHS Compliant
Lead free
Lead-free soldering

Electrostatic Sensitive Device (ESD)

B. Electrical Characteristics:

Parameter	Specification	Notes
Range Of Receiving Frequency	GPS : 1575.42 ±1.023 MHz GLONASS : 1602±5MHz	
Center Frequency	1582MHz ± 3MHz	With 50.29x50.87 mm GND Plane
Bandwidth	15MHz min	Return Loss@-10dB
VSWR	1.8 max	Center Frequency
Gain at Zenith	GPS : 1.5 dBi typ. GLONASS : 3.5 dBi typ.	Customer Prototype
Axial Ratio	- - -	
Impedance	50 Ohm	
Frequency Temperature Coefficient (τf)	-40°C to +105°C	0 ± 20ppm / °C

C. Dimension:

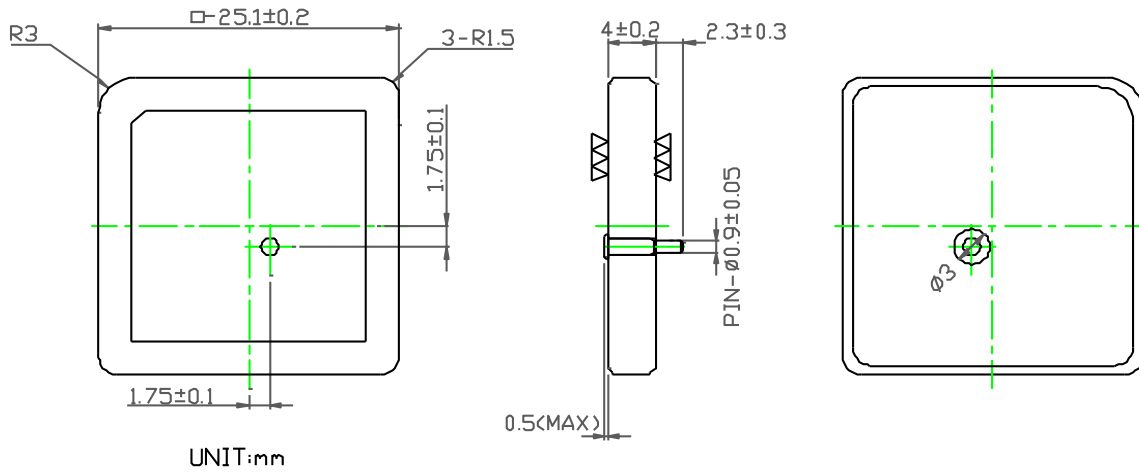

D. Frequency Characteristics:

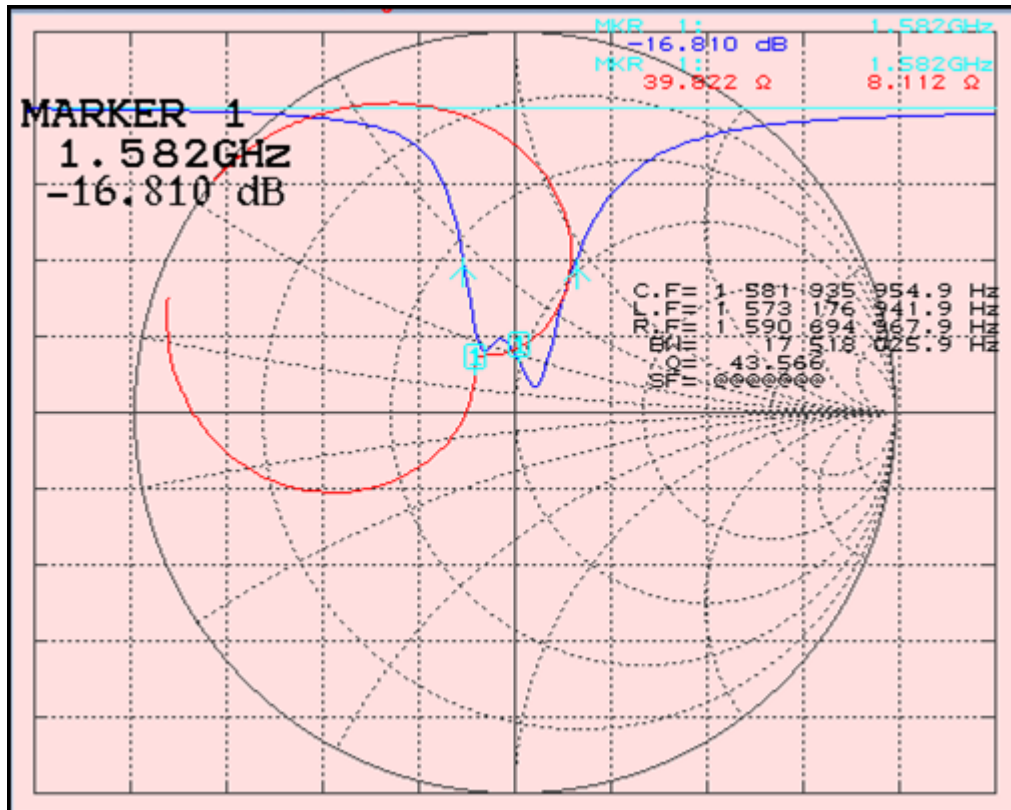

1 Layout Dimension

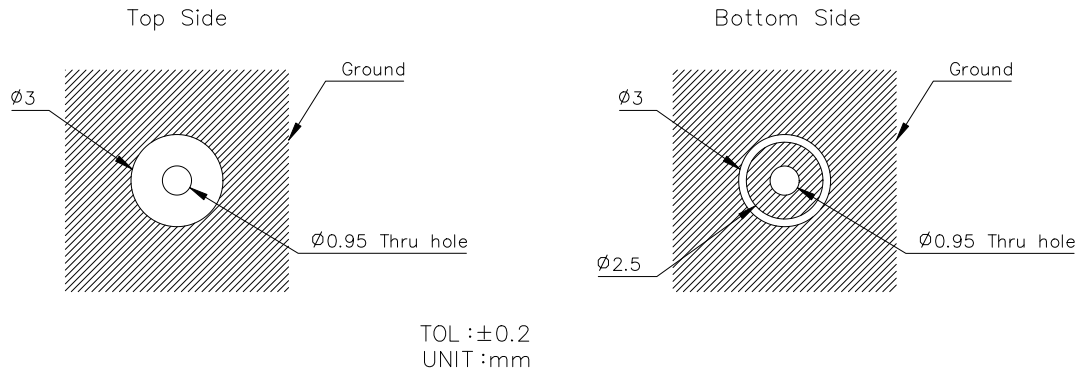

2 Tape Dimension

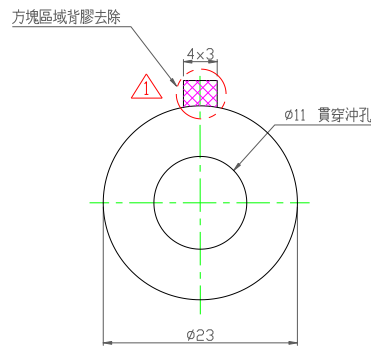

備註: 1. NITTO : NO.5015
2. Double-coated adhesive tape for industrial use
3. Thickness : 0.12mm

3 Mark

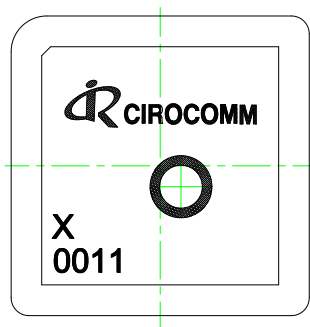

NOTE:
X: manufacture location
T: CIROCOMM TAINAN
L: CIROCOMM LOROM

4 Test Fixture Dimension

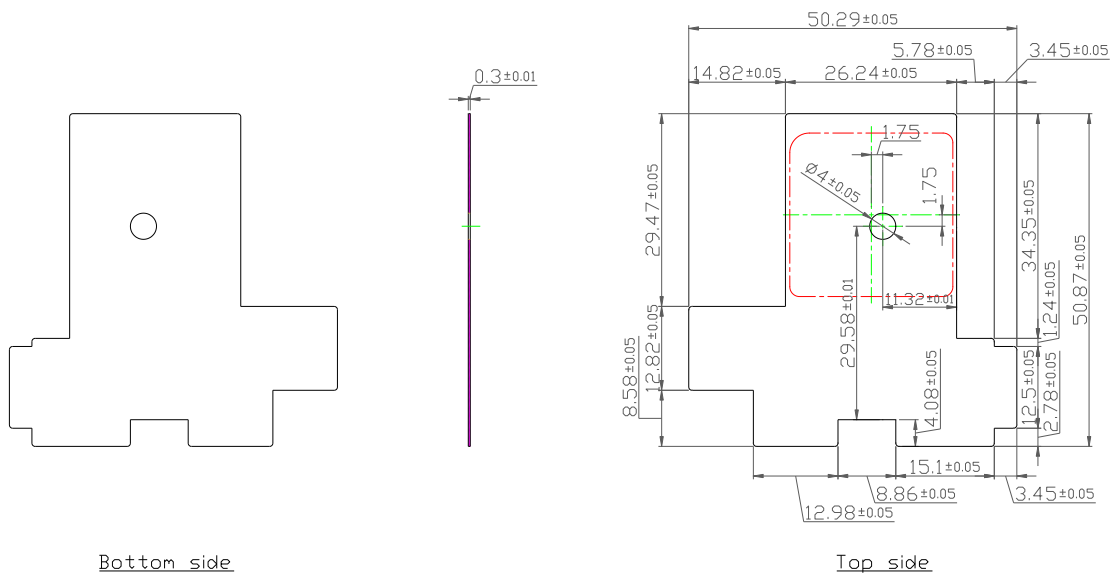

※ 註：未標示導角處尺寸為R0.5 ※

5 Test Fixture Antenna Setup & Measurements

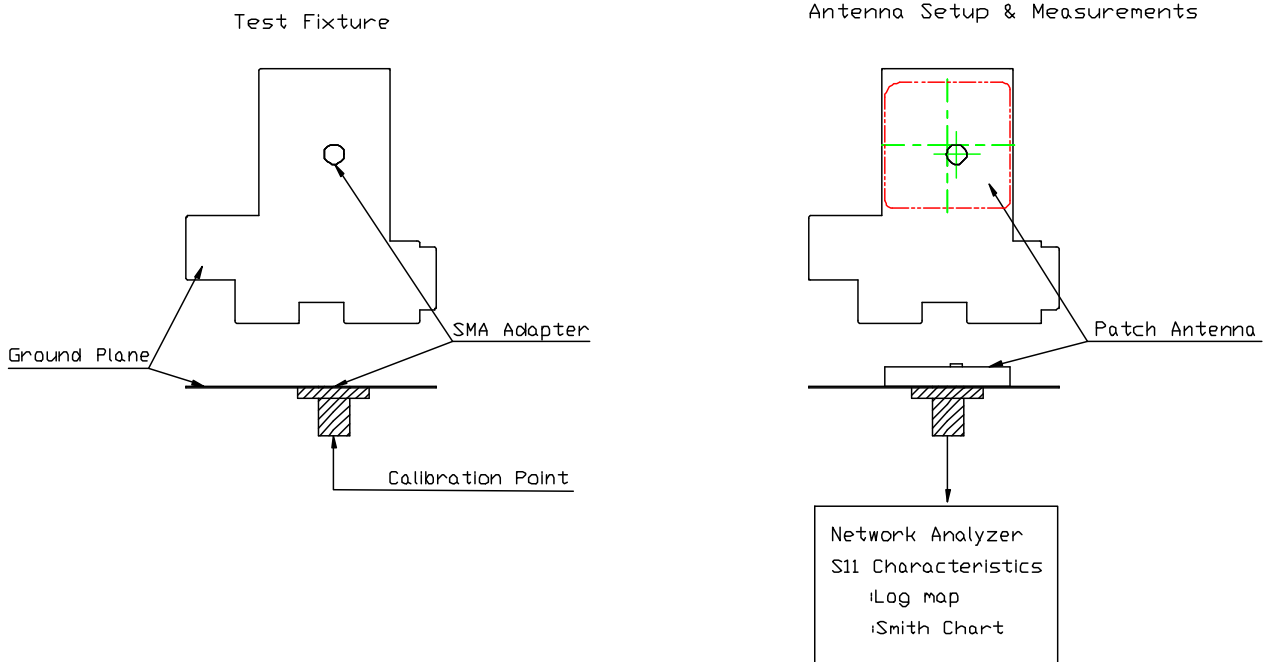

E. Packing:

