



TAI-SAW TECHNOLOGY CO., LTD.

No. 3, Industrial 2nd Rd., Ping-Chen Industrial District,
Taoyuan, 324, Taiwan, R.O.C.

TEL: 886-3-4690038 FAX: 886-3-4697532

E-mail: tstsales@mail.taisaw.com Web: www.taisaw.com

Product Specifications Approval Sheet

Product Name: Dielectric Filter .3080MHz size 8.4x3.8 mm (BW=240 MHz)

TST Parts No.: TR0031AA0090

Customer Parts No.: _____

Customer signature required
Company: _____
Division: _____
Approved by : _____
Date: _____

Checked by: _____ Hong Pu Lin *Hong Pu Lin*

Approved by: _____ Andy Yu *Andy Yu*

Date: _____ 2021/05/03

1. Customer signed back is required before TST can proceed with sample build and receive orders.
2. Orders received without customer signed back will be regarded as agreement on the specifications.
3. Any specifications changes must be approved upon by both parties and a new revision of specifications shall be released to reflect the changes.



TAI-SAW TECHNOLOGY CO., LTD.

No. 3, Industrial 2nd Rd., Ping-Chen Industrial District,
Taoyuan, 324, Taiwan, R.O.C.

TEL: 886-3-4690038 FAX: 886-3-4697532

E-mail: tstsales@mail.taisaw.com Web: www.taisaw.com

Dielectric filter 3080 MHz

MODEL NO.: TR0031AA0090

REV. NO.:2.0

A. MAXIMUM RATING:

1. DC Voltage : 0 V
2. Operating Temperature: -30°C to +85°C
3. Storage Temperature:-30°C to +85°C
4. Moisture Sensitivity Level: Level 3 (MSL3)

Electrostatic Sensitive Device (ESD)

B. ELECTRICAL CHARACTERISTICS:

Terminating source impedance (single ended) : $Z_s = 50 \Omega$

Terminating load impedance (single ended) : $Z_L = 50 \Omega$

Item	Specifications (at 25°C)
Center Frequency (Fo)	3080.0 MHz
Pass Bandwidth (BW)	2960 ~ 3200 MHz (240MHz)
Insertion Loss @ BW	2.0 dB max.
Ripple @ BW	1.2 dB max.
Return Loss @ BW (S11)	10 dB min.
Attenuation	8 dB min. @ 2900.0 MHz
In /Out Impedance	50Ω
Operation Temperature Range	-30°C ~ +85°C

D. Frequency Characteristics:

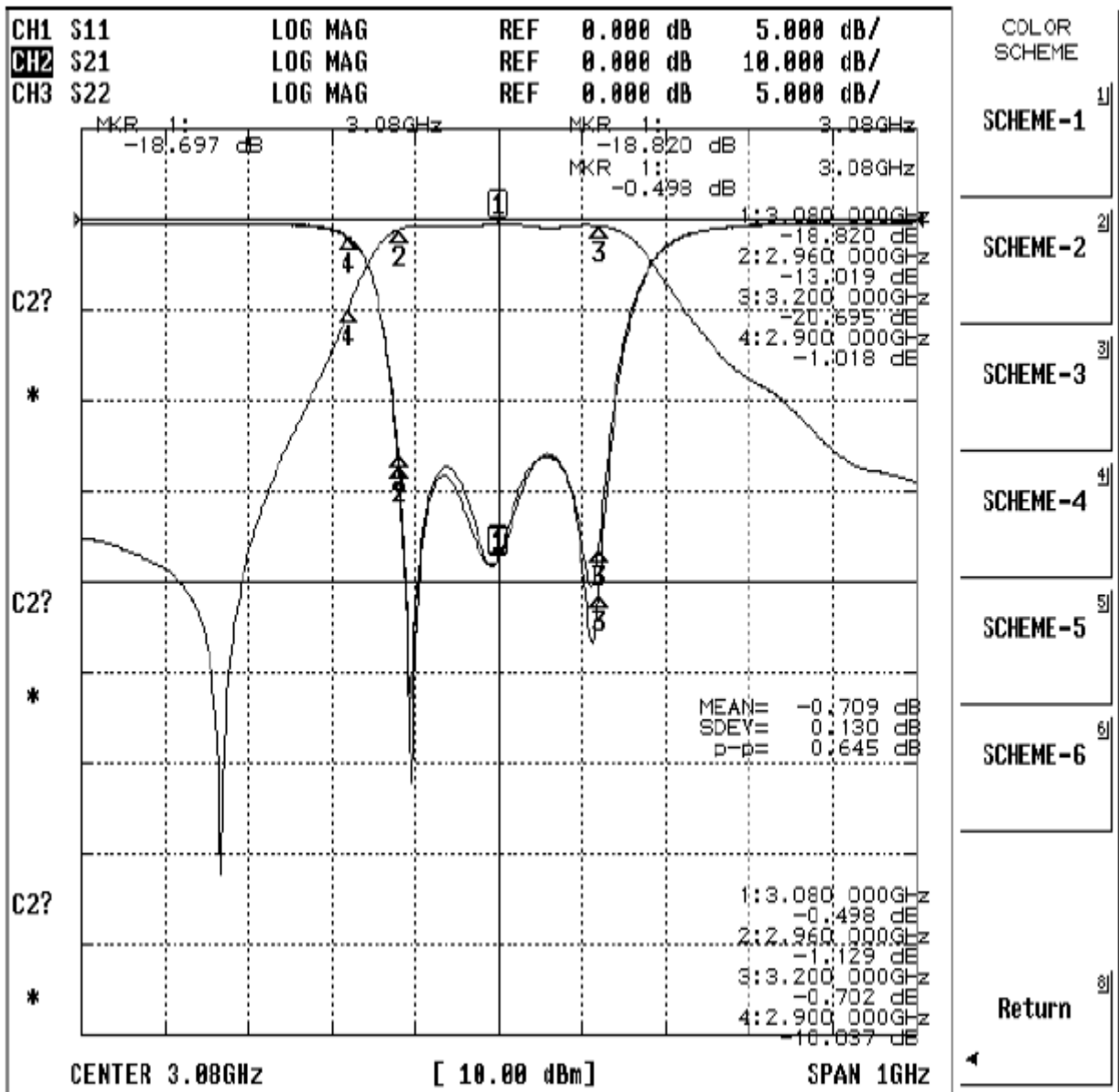

E. Packaging Style

1 The dimensions of carrier tape is in Figure 4.

2 The dimensions of reel is shown in Figure 5.

3 The taping condition is shown in Figure 6.

4 Beginning of winding

When the tape runs out, it can be remove the reel easily.

5 End of Winding

Leader part shall be taped on the edge of the reel.

6 The pilot hole is in the left side to the feed direction of the tape shown in the Figure 5.

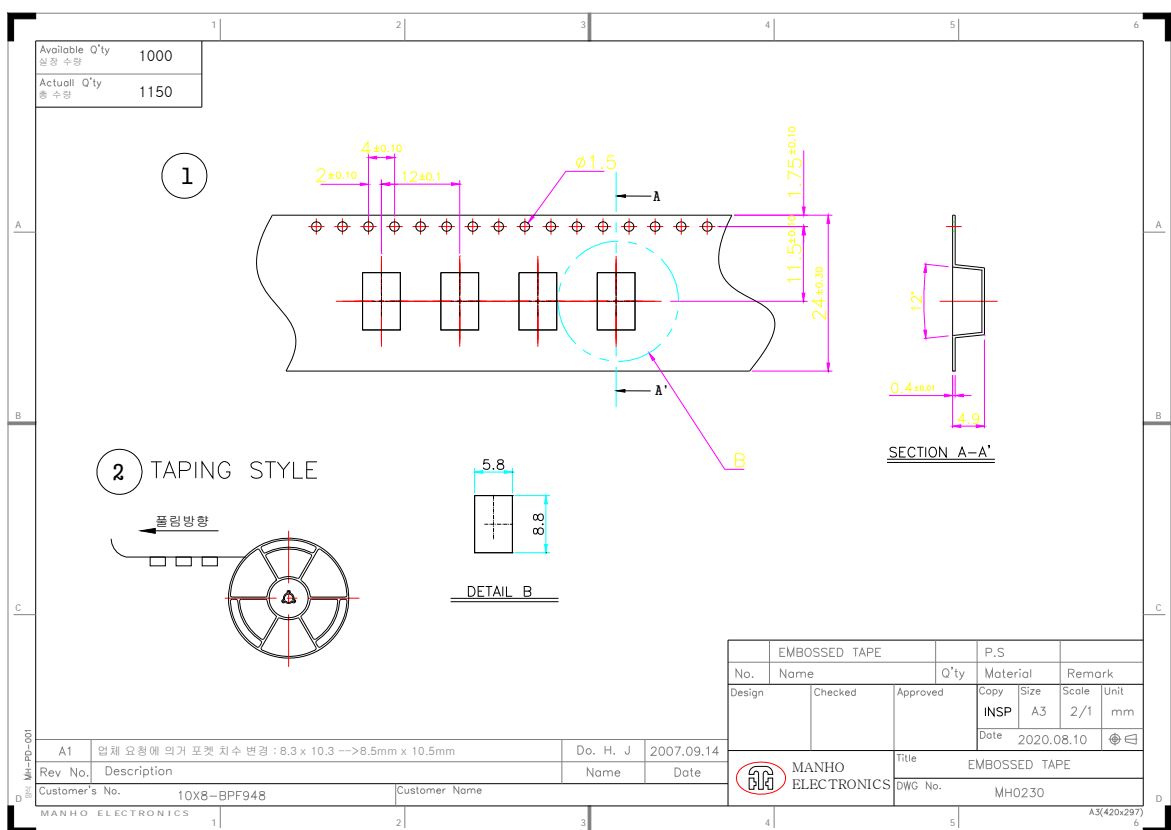
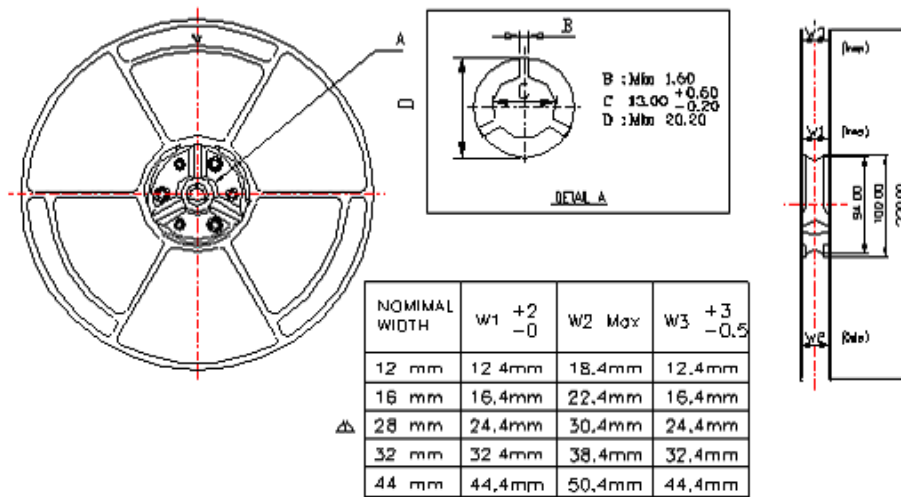
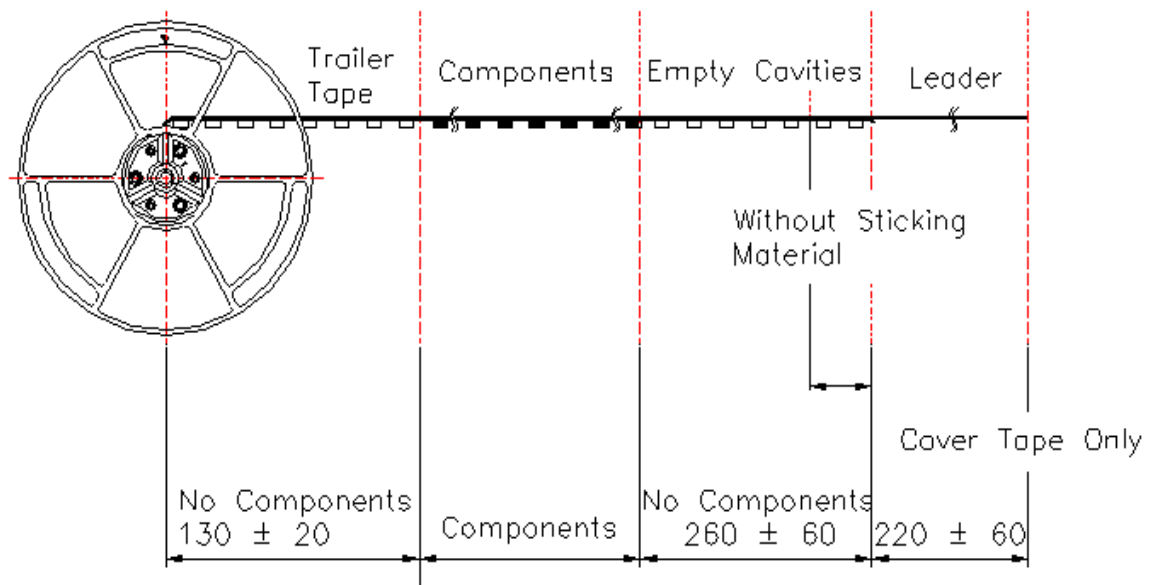

Figure 4. dimensions of carrier tape



Note :
1. Unit : mm

FIGURE 5. Dimension of Reel.



Note :
1. Unit : mm

FIGURE 6. Taping Conditions.

F. Packing quantity

Item	Quantity (pcs)	Dimension (mm)
Reel Taping	1,000	ψ330 x 44H
Inner Box	2,000	360 x 350 x 55H
Out Box	10,000	570 x 360 x 560H