



TAI-SAW TECHNOLOGY CO., LTD.

No. 3, Industrial 2nd Rd., Ping-Chen Industrial District,
Taoyuan, 324, Taiwan, R.O.C.

TEL: 886-3-4690038 FAX: 886-3-4697532

E-mail: tstsales@mail.taisaw.com Web: www.taisaw.com

Product Specifications Approval Sheet

Product Description: Dielectric Filter 5665MHz BW 370MHz Size8.46x3.45mm
TST Parts No.: TR0134AA0090

Customer Parts No.: _____

Customer signature required
Company: _____
Division: _____
Approved by : _____
Date: _____

Checked by: _____ Nina Chen *Nina Chen*

Approved by: _____ Kazuma Lee *Kazuma Lee*

Date: _____ 2023/07/07

1. Customer signed back is required before TST can proceed with sample build and receive orders.
2. Orders received without customer signed back will be regarded as agreement on the specifications.
3. Any specifications changes must be approved upon by both parties and a new revision of specifications shall be released to reflect the changes.



TAI-SAW TECHNOLOGY CO., LTD.

No. 3, Industrial 2nd Rd., Ping-Chen Industrial District,
Taoyuan, 324, Taiwan, R.O.C.

TEL: 886-3-4690038 FAX: 886-3-4697532

E-mail: tstsales@mail.taisaw.com Web: www.taisaw.com

Dielectric Filter 5665MHz BW 370MHz Size 8.46x3.45mm

MODEL NO.: TR0134AA0090

REV. NO.:1.0

A. Maximum Rating:

1. Input Power:1W
2. Operating Temperature: -40°C to +85°C
3. Storage Temperature: 0°C to +40°C
4. Moisture Sensitivity Level: 2a(MSL 2a)

RoHS Compliant
Lead free
Lead-free soldering

Electrostatic Sensitive Device (ESD)

B. Electrical Characteristics:

ITEM		SPECIFICATION		
		Min	Typ	Max
INSERTION LOSS	5480~5850 MHz		1.5 dB	2.0 dB
RIPPLE	5480~5850 MHz		0.8 dB	1.5 dB
RETURN LOSS	5480~5850 MHz	10 dB	12 dB	
ATTENUATION	at 5150~5340 MHz	35 dB	38dB	
ATTENUATION specifies the absolute value of attenuation.				

C. Frequency Characteristics:

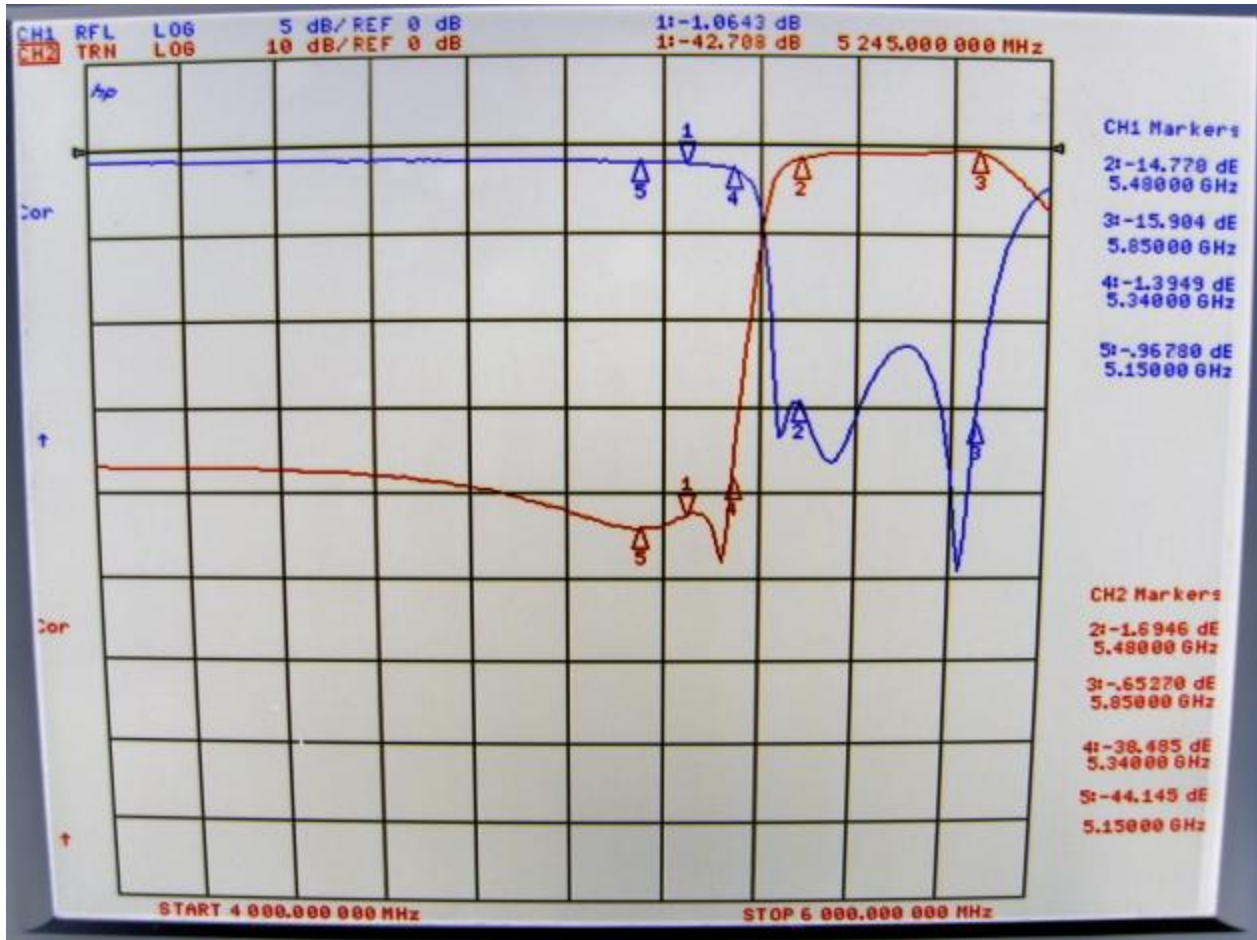

D. Dimension:

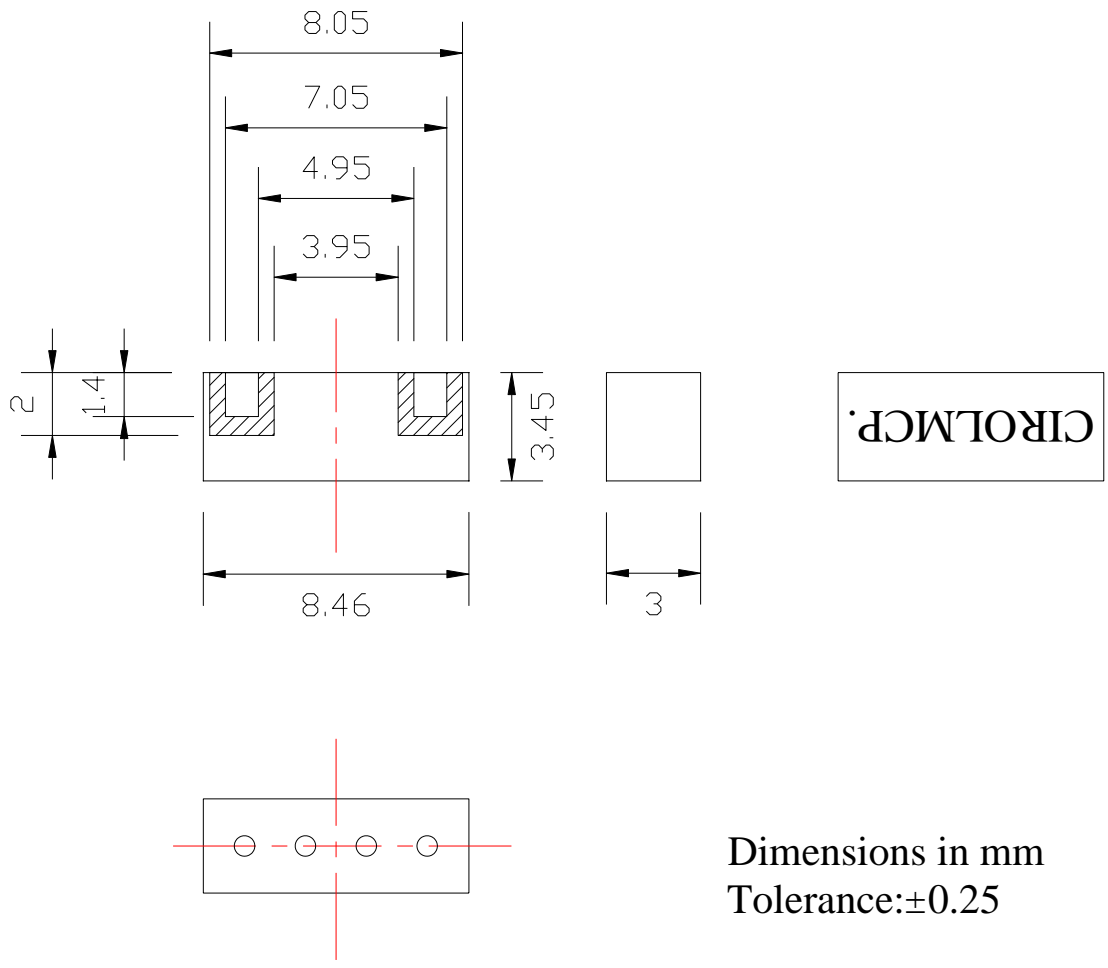

Dimensions in mm
Tolerance:±0.25

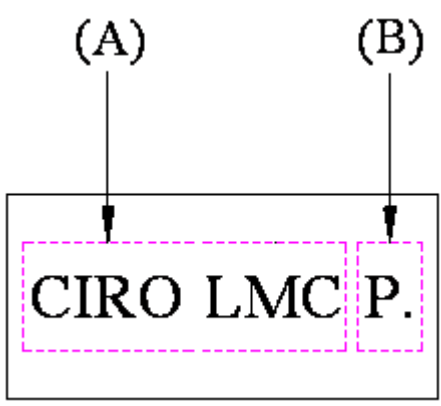

- (A) Product name : CIRO LMC
- (B) Year/Month : Please refer to the Table-1

(Table-1)

Year	Month	Code	Year	Month	Code	Year	Month	Code	Year	Month	Code
2012 2016 2020 2024	1	A	2013 2017 2021 2025	1	N	2014 2018 2022 2026	1	A.	2015 2019 2023 2027	1	N.
	2	B		2	P		2	B.		2	P.
	3	C		3	Q		3	C.		3	Q.
	4	D		4	R		4	D.		4	R.
	5	E		5	S		5	E.		5	S.
	6	F		6	T		6	F.		6	T.
	7	G		7	U		7	G.		7	U.
	8	H		8	V		8	H.		8	V.
	9	J		9	W		9	J.		9	W.
	10	K		10	X		10	K.		10	X.
	11	L		11	Y		11	L.		11	Y.
	12	M		12	Z		12	M.		12	Z.

E. PCB Footprint:

Conductive Material Patten

Solder resist Patten

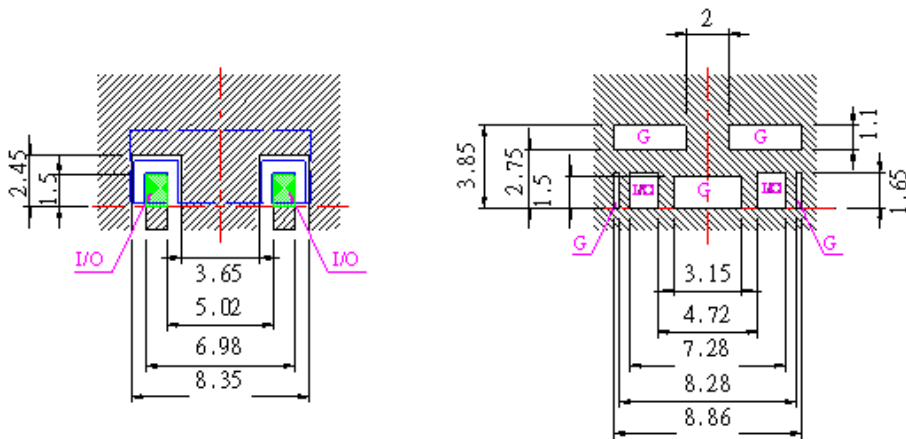

Tolerance ± 0.20
 I/O : Input/Output
 G : Ground

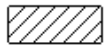

Electrode



Solder Resist



I/O Pads must be connected to lines with 50Ω impedance. In the application a termination of 50Ω must be realized.

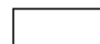

Solder LAND

3-2-3

Shielding case layout guide (min)

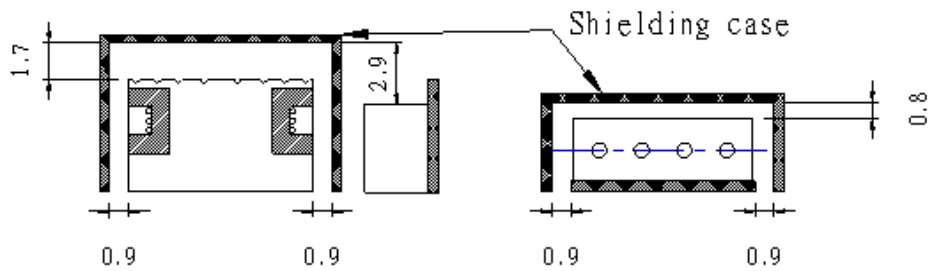

F.Packing:

1.Reel Dimension:

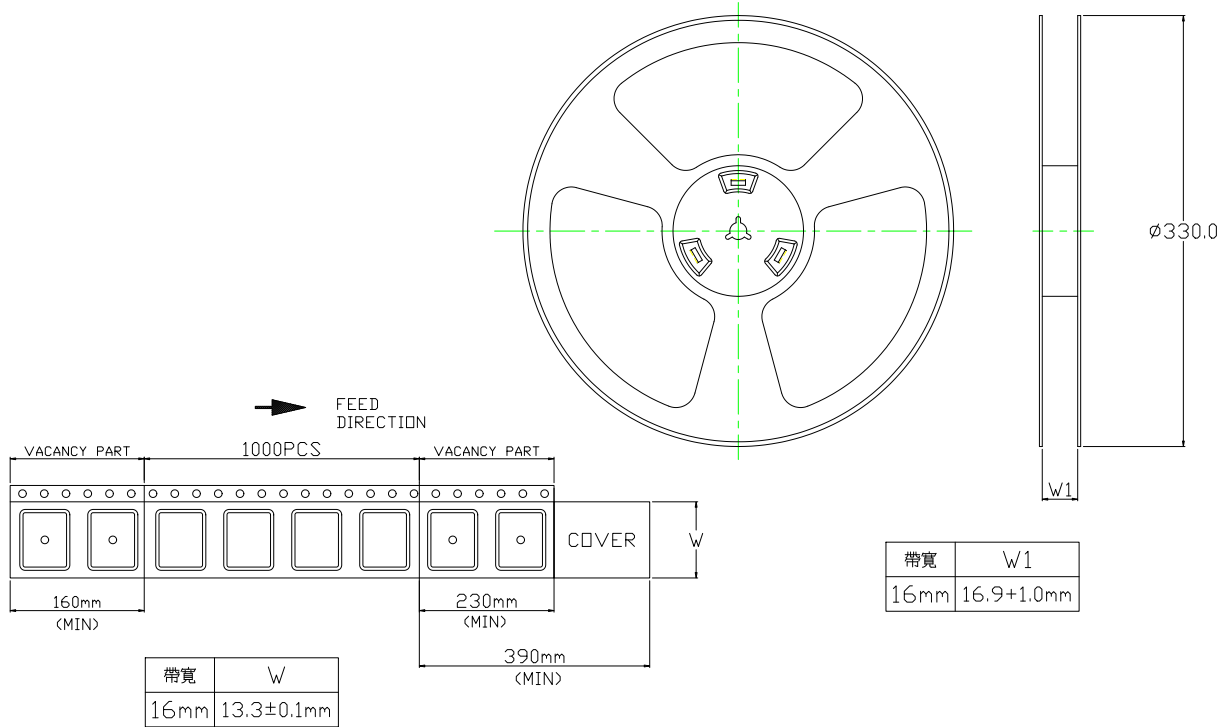

2.Tape Dimension:

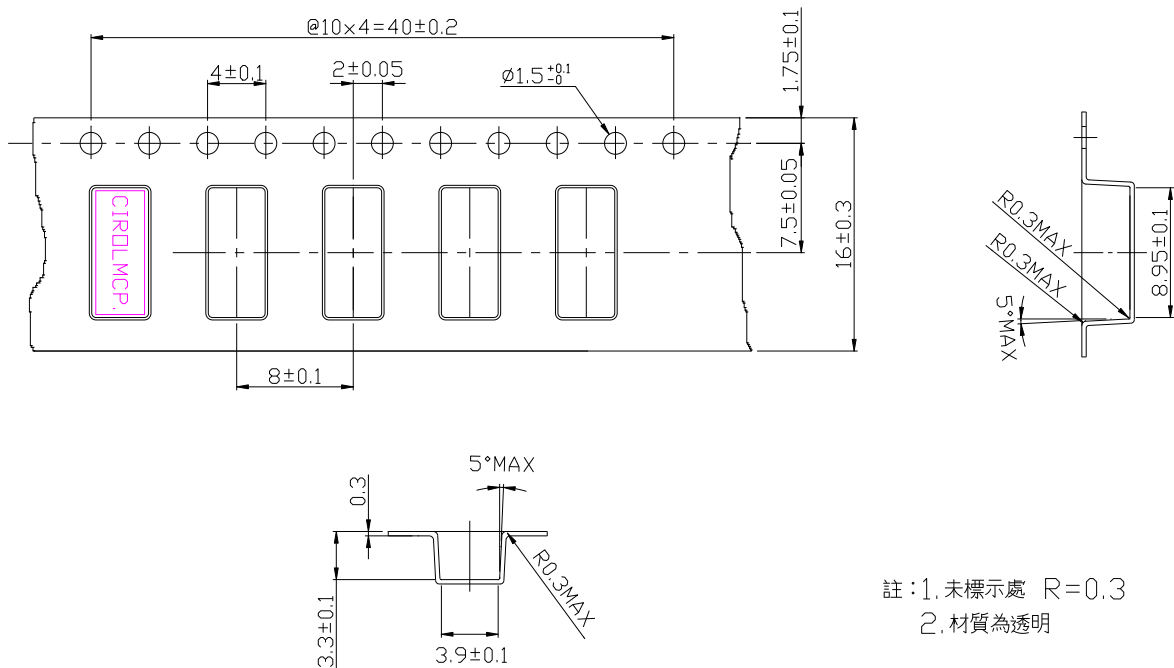

3.Package style:

- 1. Outer Carton
Quanyity:5000PCS

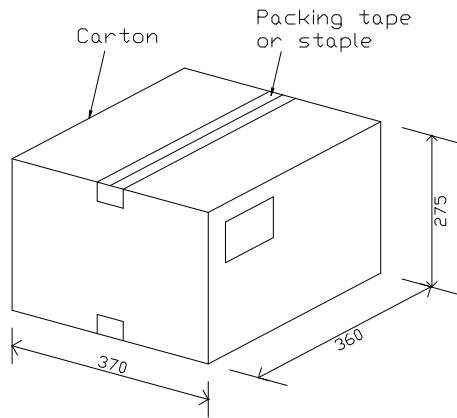

- 2. Inner Carton
Quanyity:1000PCS

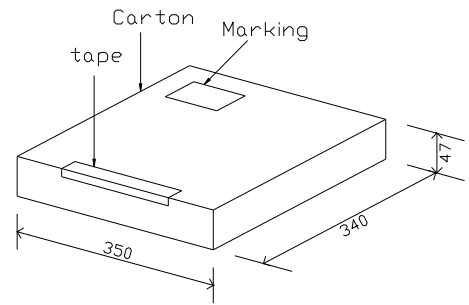

- 3. Bag
Quanyity:1000PCS

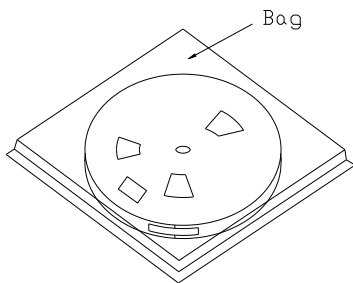

- 4. Taping
Quanyity:1000PCS

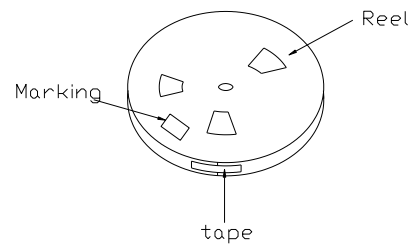

Unit:mm

G. Recommended Reflow Profile:

Products can be assembled following Pb-free assembly. According to the Standard **IPC/JEDEC J-STD-020C**, the temperature profile suggested is as follow:

Phase	Profile features	Pb-Free Assembly (SnAgCu)
PREHEAT	-Temperature Min(T_{smin}) -Temperature Max(T_{smax}) -Time(t_s) form (T_{smin} to T_{smax})	150°C 200°C 60-120 seconds
RAMP-UP	Avg. Ramp-up Rate (T_{smax} to T_P)	3°C/second(max)
REFLOW	-Temperature(T_L) -Total Time above T_L (t_L)	217°C 30-100 seconds
PEAK	-Temperature(T_P) -Time(t_p)	260°C 3 second
RAMP-DOWN	Rate	6°C / second max.
Time from 25°C to Peak Temperature		8 minutes max.
Composition of solder paste		96.5Sn/3Ag/0.5Cu
Solder Paste Model		SHENMAO PF606-P26

Note : All the temperature measure point is on top surface of the component, if temperature over recommend, it will make component surface peeling or damage.

The graphic shows temperature profile for component assembly process in reflow ovens

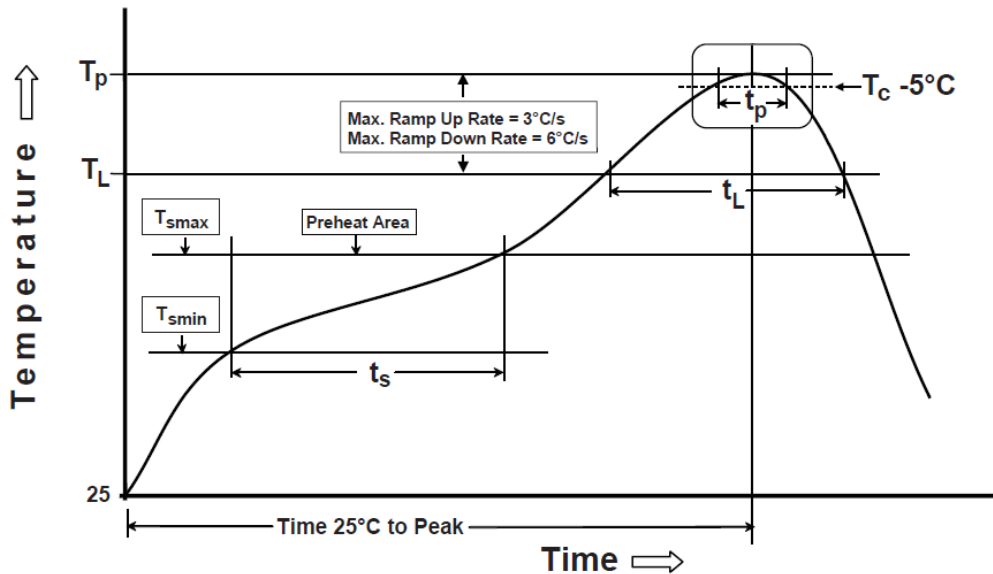

Soldering With Iron:

Soldering condition : Soldering iron temperature 270 ± 10 °C .

Apply preheating at 120°C for 2-3 minutes. Finish soldering for each terminal within 3 seconds, if soldering iron over temperature 270 ± 10 °C or 3 seconds, it will make component surface peeling or damage.

Soldering iron can not leakage of electricity.