



TAI-SAW TECHNOLOGY CO., LTD.

No. 3, Industrial 2nd Rd., Ping-Chen Industrial District,
Taoyuan, 324, Taiwan, R.O.C.

TEL: 886-3-4690038 FAX: 886-3-4697532

E-mail: tstsales@mail.taisaw.com Web: www.taisaw.com

Product Specifications Approval Sheet

Product Description: Dielectric Duplexer Filter 897.5/942.5MHz BW35/35MHz
Size 42.5x17.5mm

TST Parts No.: TR0136AA0090

Customer Parts No.: _____

Customer signature required
Company: _____
Division: _____
Approved by : _____
Date: _____

Checked by: _____ Nina Chen *Nina Chen*

Approved by: _____ Kazuma Lee *Kazuma Lee*

Date: _____ 2023/08/25

1. Customer signed back is required before TST can proceed with sample build and receive orders.
2. Orders received without customer signed back will be regarded as agreement on the specifications.
3. Any specifications changes must be approved upon by both parties and a new revision of specifications shall be released to reflect the changes.



TAI-SAW TECHNOLOGY CO., LTD.

No. 3, Industrial 2nd Rd., Ping-Chen Industrial District,
Taoyuan, 324, Taiwan, R.O.C.

TEL: 886-3-4690038 FAX: 886-3-4697532

E-mail: tstsales@mail.taisaw.com Web: www.taisaw.com

Dielectric Duplexer Filter 897.5/942.5MHz BW35/35MHz Size42.5x17.5mm

MODEL NO.: TR0136AA0090

REV. NO.:1.0

A. Maximum Rating:

1. Input Power:3W max.
2. Operating Temperature: -40°C to +85°C
3. Storage Temperature: 0°C to +40°C
4. Moisture Sensitivity Level: 2a(MSL 2a)

RoHS Compliant
Lead free
Lead-free soldering

Electrostatic Sensitive Device (ESD)

B. Electrical Characteristics:

ITEM	UNIT	Low>>ANT	ANT>>High
		880~915 MHz	925~960 MHz
Center Frequency	MHz	897.5	942.5
INSERTION LOSS	dB	2.5max.	2.5max.
RIPPLE	dB	1.5max.	1.5max.
RETURN LOSS	dB	15min.	15min.
ATTENUATION	dB	40min. @925~960MHz	40min. @880~915MHz
ISOLATION	dB	40min. @925~960MHz 40min. @880~915MHz	

C. Frequency Characteristics:

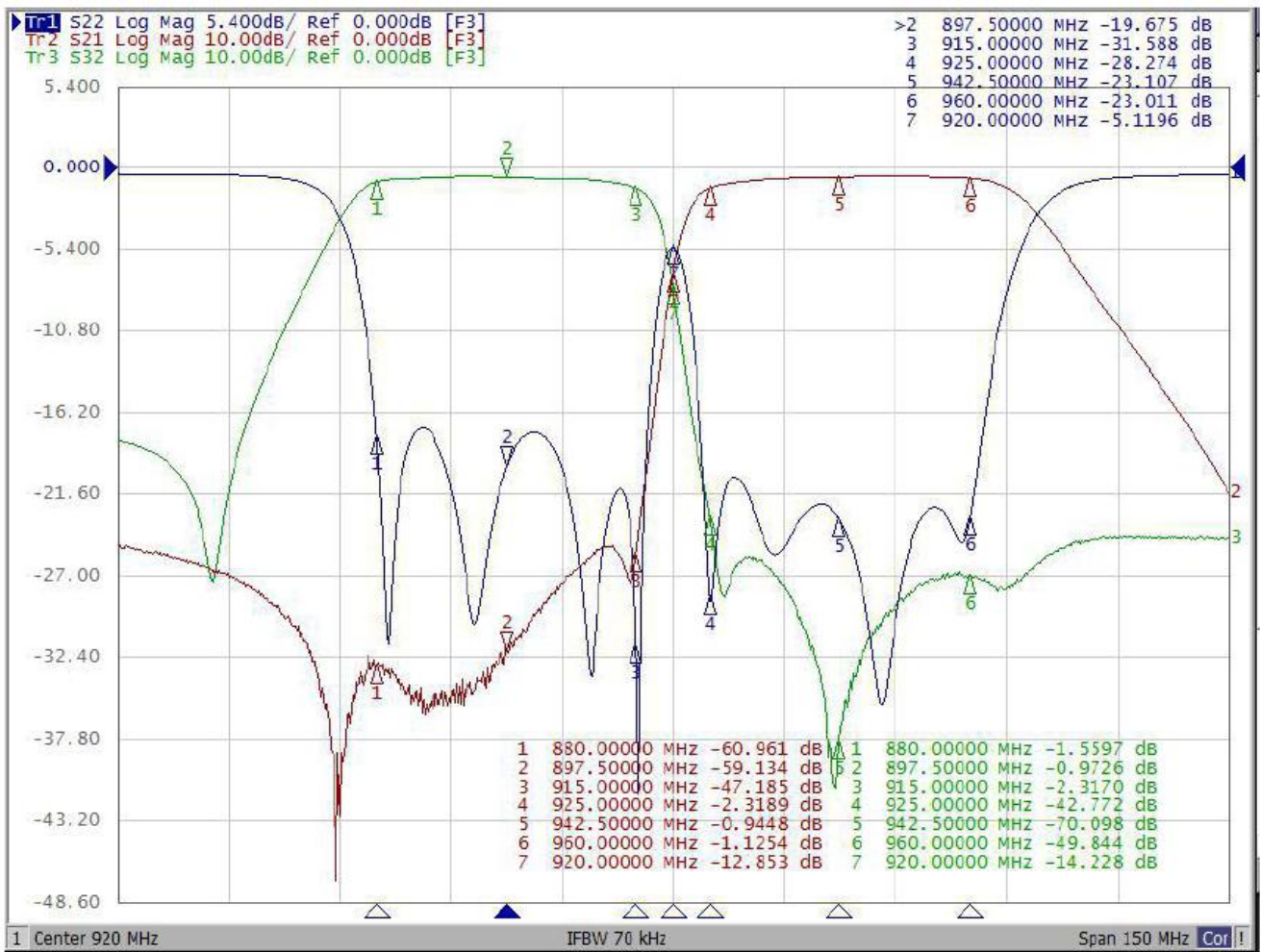

D. Dimension:

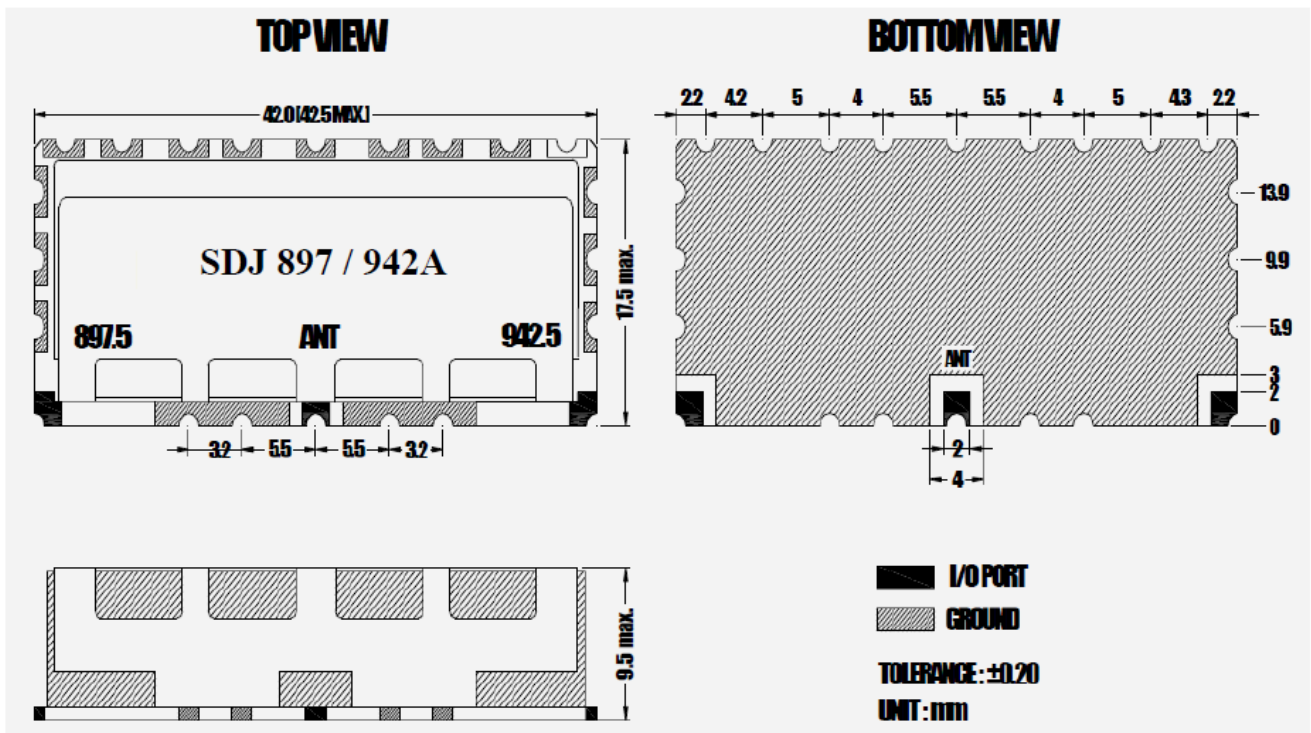

E. PCB Footprint:

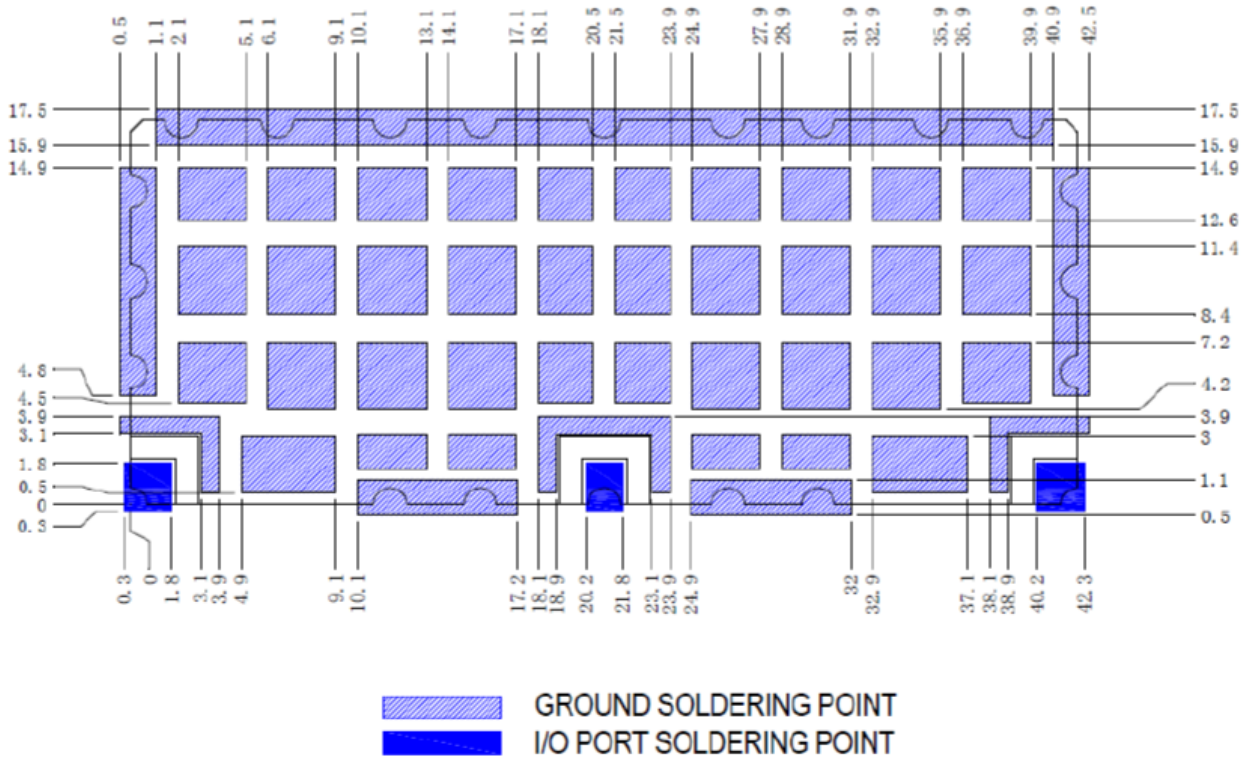

F. Packing:

Blister Box Size(20pcs)

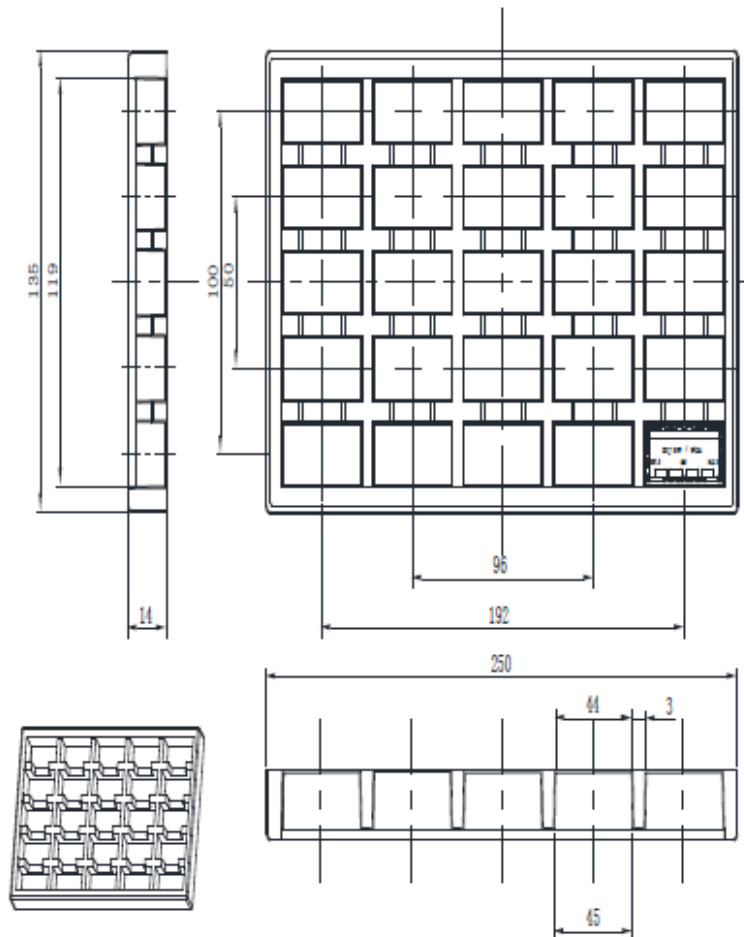

(4 Blister Box / Inner Carton)

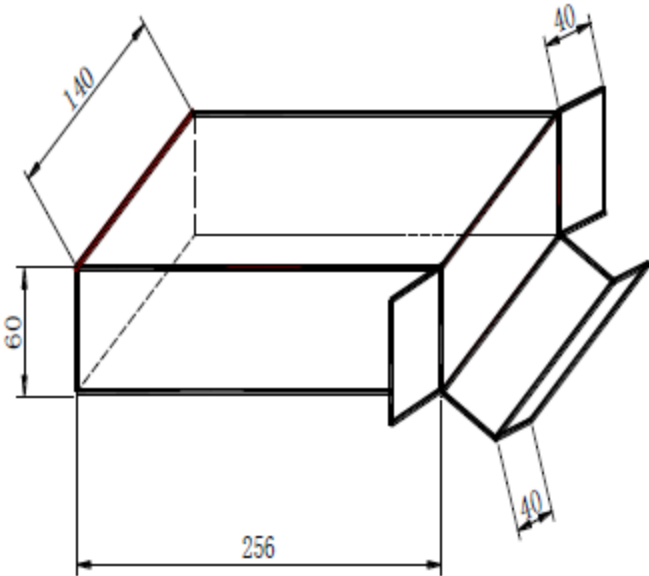

(4 Inner Carton / Outer Carton)

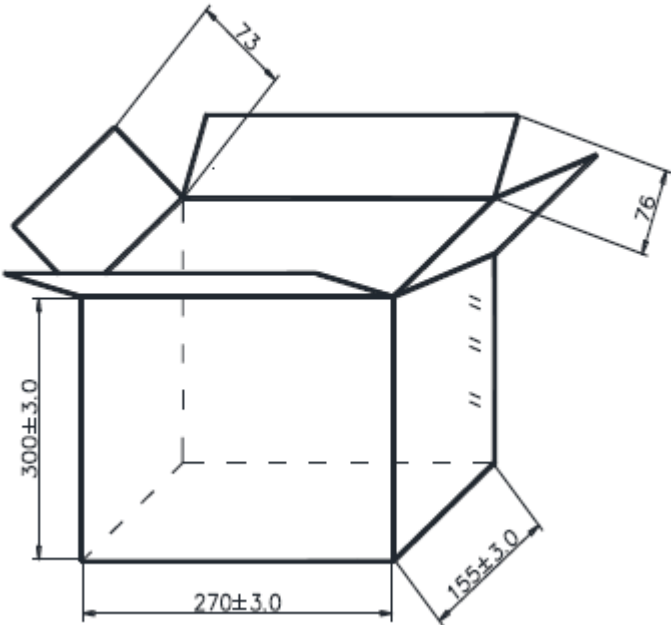

G. Recommended Reflow Profile:

Profile feature		Pb-Free Assembly (SnAgCu)
PREHEAT	Temperature Min(T_{smin}) Temperature Max(T_{smax}) Time(t_s) (from T_{smin} to T_{smax})	150°C 200°C 60-120 seconds
RAMP-UP	Ramp-up rate (TL to TP)	3 °C/second max
REFLOW	Liquidus Temperature(TL) Total Time maintained above TL (t_L)	217°C 30-100 seconds
PEAK	Temperature(TP) Time (t_p)	260°C 5 seconds
RAMP-DOWN	Ramp-down rate (TP to TL)	6 °C / second max.
Time (from 25°C to Peak Temperature) 25°C		8 minutes max.

