



TAI-SAW TECHNOLOGY CO., LTD.

No. 3, Industrial 2nd Rd., Ping-Chen Industrial District,
Taoyuan, 324, Taiwan, R.O.C.

TEL: 886-3-4690038 FAX: 886-3-4697532

E-mail: tstsales@mail.taisaw.com Web: www.taisaw.com

Product Specifications Approval Sheet

Product Description: VCXO SMD 7.0x5.0 122.88MHz

TST Part No.: TV0171WA6215

Customer Part No.: _____

Customer signature required
Company: _____
Division: _____
Approved by : _____
Date: _____

Checked by: _____ Yifan Chen *Yifan*

Approved by: _____ Kelly Huang *Kelly Huang*

Date: _____ 06/27/2023

1. Customer signed back is required before TST can proceed with sample build and receive orders.
2. Orders received without customer signed back will be regarded as agreement on the specifications.
3. Any specifications changes must be approved upon by both parties and a new revision of specifications shall be released to reflect the changes.



TAI-SAW TECHNOLOGY CO., LTD.

SMD 7.0x5.0 122.88MHz VCXO

MODEL NO.: TV0171WA6215

REV. NO.: 1.0

Revise:

Rev.	Rev. Page	Rev. Account	Date	Ref. No.	Reviser
1	N/A	Initial release	06/27/23'	N/A	Yifan Chen



TAI-SAW TECHNOLOGY CO., LTD.

No. 3, Industrial 2nd Rd., Ping-Chen Industrial District,
Taoyuan, 324, Taiwan, R.O.C.

TEL: 886-3-4690038 FAX: 886-3-4697532

E-mail: tstsales@mail.taisaw.com Web: www.taisaw.com

SMD 7.0x5.0 122.88MHz VCXO

MODEL NO.: TV0171WA6215

REV. NO: 1.0

Features:

1. 3.3V Operation / PECL Output
2. Enable / Disable Function (8-Pad)
3. Main application: WLAN, SONET/SDH/DWDM, Gigabite Ethernet, Storage Area Network, Digital Video
4. Surface mount 7.0mmx5.0mm crystal oscillator
5. Moisture Sensitivity Level (MSL) : Level-1

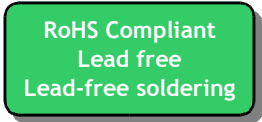

Electrical Characteristics:

	Parameters	SYM.	Electrical Spec.				Notes
			Min.	Typical	Max.	Unit	
1	Nominal Frequency	FL	122.880000			MHz	
2	Holder Type		-				7.0 * 5.0 * 1.8 mm , 8pads , SMD Type
3	Input Voltage	VCC		3.3		V	D.C ± 10 %
4	Output Wave Form						Square Wave (PECL)
5	Output Voltage High " 1 "	Voh	2.135		2.5	V	V _{DD} - 1.165 (min.) , V _{DD} - 0.8 (max.)
6	Output Voltage Low " 0 "	VoL	1.3		1.75	V	V _{DD} - 2.0 (min.) , V _{DD} - 1.55 (max.)
7	Frequency Stability	F _{opr}	-25		25	ppm	Over Operating Temperature
8	Frequency Deviation Range	Pulling	±100			ppm	Control Voltage Range : 0.3V ~ 3.0V
9	Current Consumption	I _{DD}		100		mA	measured with terminating resistors
	Current with output disabled	I _{op}		99		mA	
10	Output Voltage Swing	V _{sw}	595		930	mV	
11	Rise Time & Fall Time	Tr , Tf			0.4	n Sec.	20 % ↔ 80 % of waveform
12	Duty Cycle	tw/t	45		55	%	at 50 % waveform
13	Star -up Time	ST		5.0	10	m Sec.	
14	Load	RL		50		Ω	Into VCC - 2V or Thevenin equivalent
15	RMS phase Jitter	J _{rms}		0.15		ps	F _j = 12 kHz ~ 20 MHz
16	Linearity			5	10	%	

17	Operating Temperature	T_use	-40		85	°C	
18	Storage Temperature	T_stg	-55		105	°C	
19	Aging	F_aging	-3		3	ppm	first year
20	Phase Noise (dBc/Hz)	10 Hz	100 Hz	1k Hz	10k Hz	1M Hz	10M Hz
		-43	-84	-113	-133	-151	-156
21	Tri-state function on Pad 2	Tri - State enable high. No connection or 70% of VDD min. is applied to Tri - State pad to enable output. 30% of VDD max. to disable output (high impedance)					

Mechanical Dimensions: (Unit: mm)

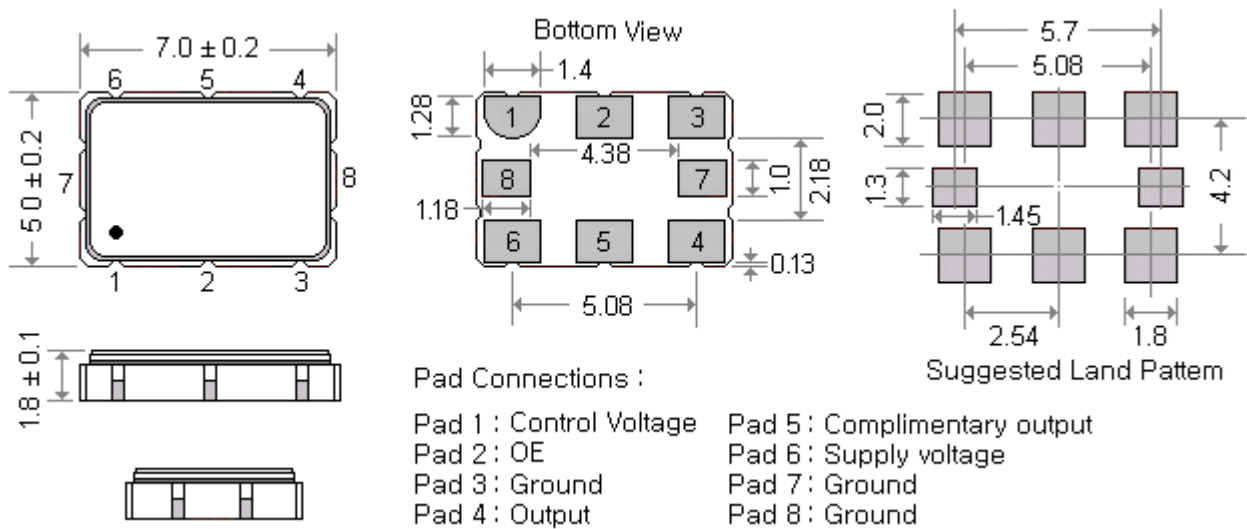

Test Circuit:

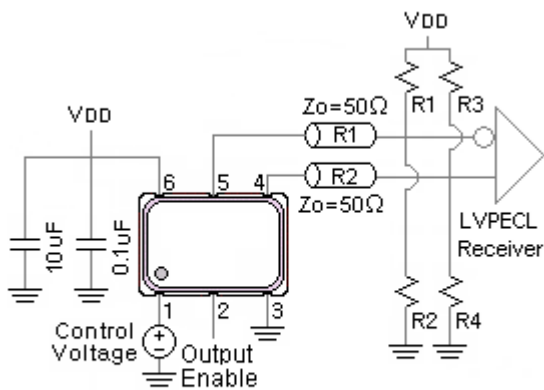

VDD = 3.3 V : R1 = R3 = 127 Ω ; R2 = R4 = 82.5 Ω
VDD = 2.5 V : R1 = R3 = 250 Ω ; R2 = R4 = 62.5 Ω

Output Waveform :

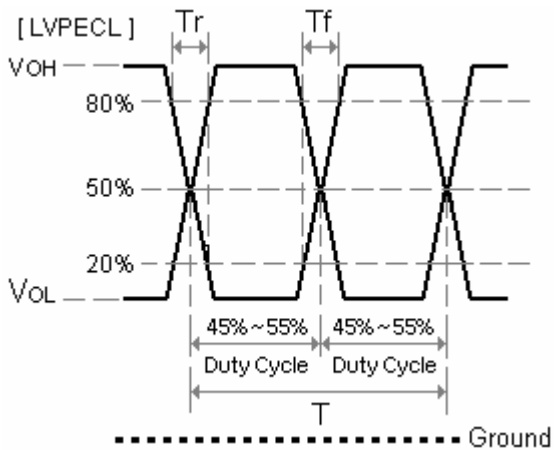

Marking :

Line 1 : Frequency (122.880)

Line 2 : $\text{\textcircled{T}}$ XDXX (TST Logo + Product Code + Date Code + Internal Traceability Code (XX) :

Can be 1 or 2 letters)

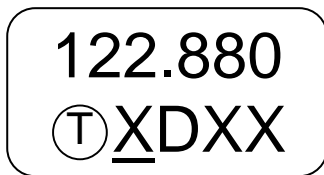

Product Code Table

Year	2021	2022	2023	2024
	2025	2026	2027	2028
	2029	2030	2031	2032
Product code	X	x	<u>X</u>	<u>x</u>

Date Code Table

WK01	WK02	WK03	WK04	WK05	WK06	WK07	WK08	WK09	WK10	WK11	WK12	WK13
A	B	C	D	E	F	G	H	I	J	K	L	M
WK14	WK15	WK16	WK17	WK18	WK19	WK20	WK21	WK22	WK23	WK24	WK25	WK26
N	O	P	Q	R	S	T	U	V	W	X	Y	Z
WK27	WK28	WK29	WK30	WK31	WK32	WK33	WK34	WK35	WK36	WK37	WK38	WK39
a	b	c	d	e	f	g	h	i	j	k	l	m
WK40	WK41	WK42	WK43	WK44	WK45	WK46	WK47	WK48	WK49	WK50	WK51	WK52
n	o	p	q	r	s	t	u	v	w	x	y	z

Reel Dimensions (mm):

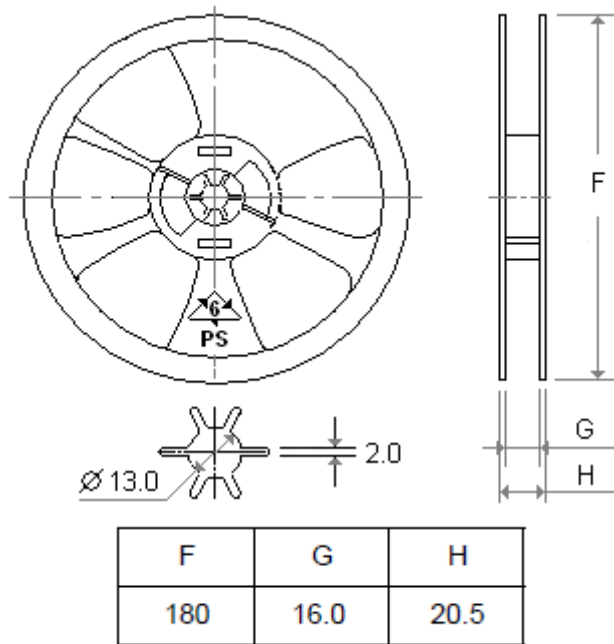

Tape Dimensions (mm):

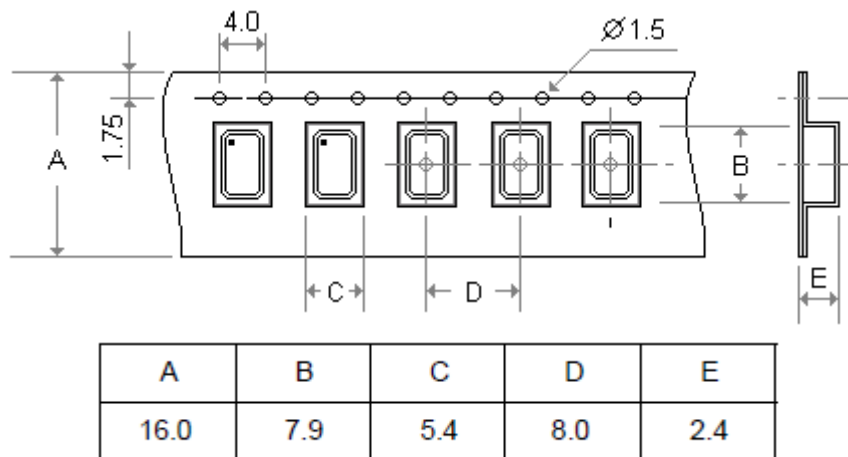

PACKING DIRECTION:

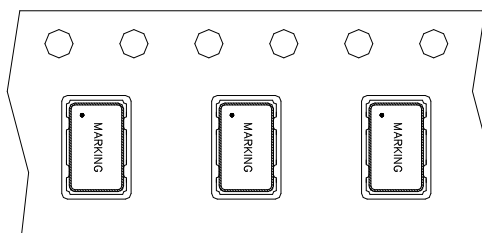

Packing Quantity/Packing:

1K pcs maximum per reel

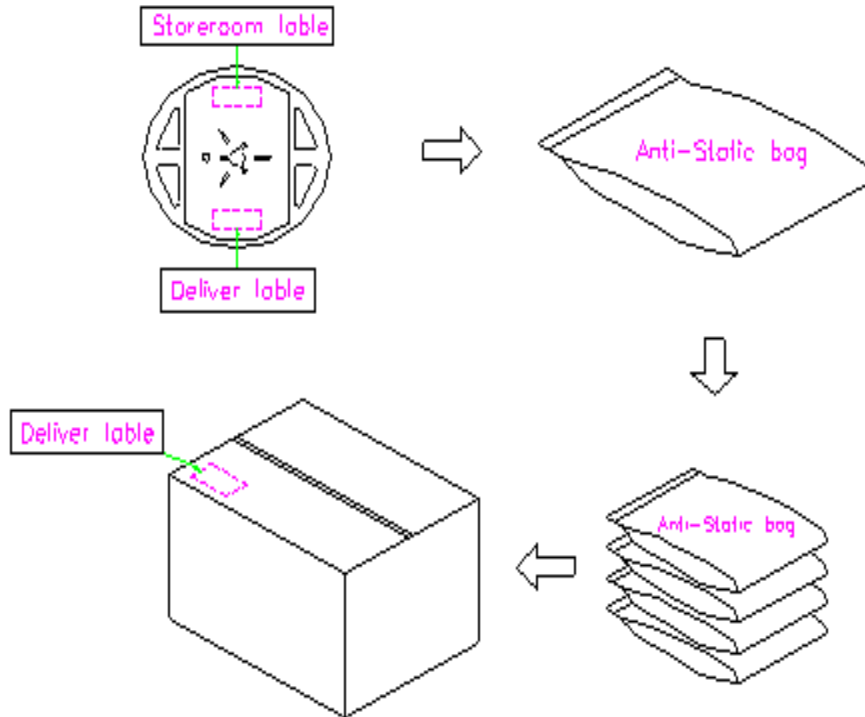

Reflow Profile:

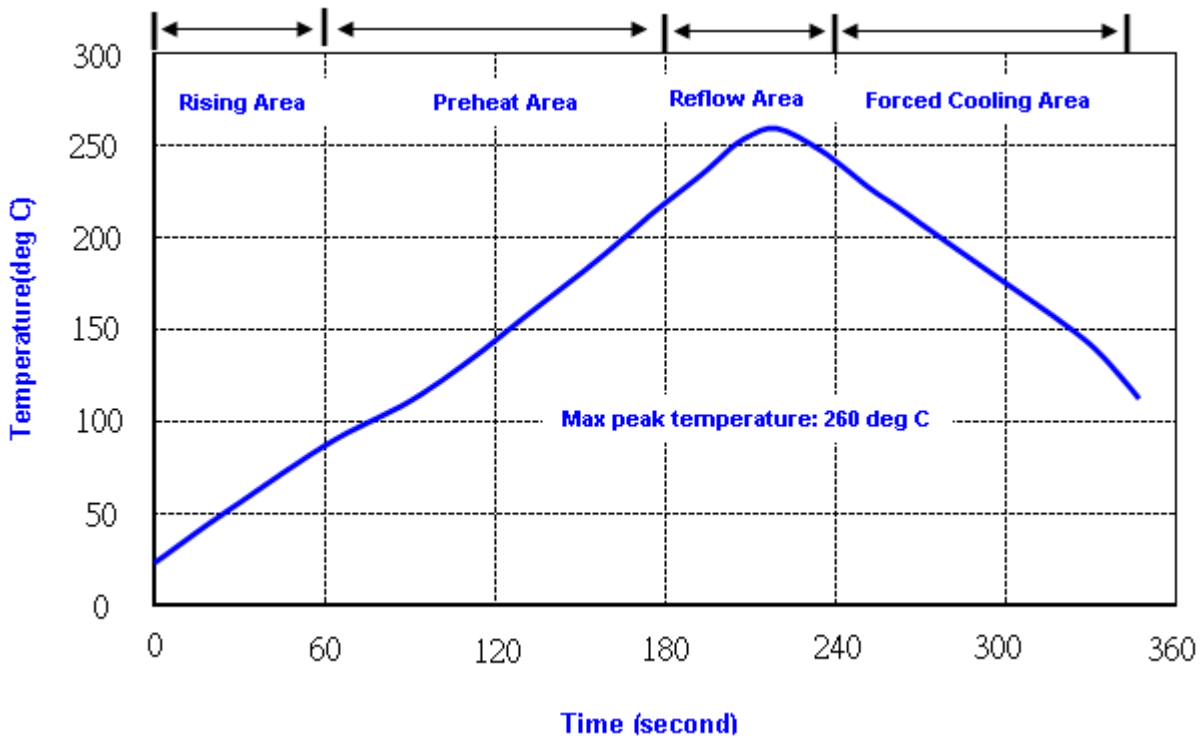

Note: 1. Max peak temperature: 260 +/- 5 deg C; Time: 10 +/- 2 sec
2. Temperature: 217 +/- 5 deg C; Time: 90~100 sec

Reliability Specifications

Test name	Test process / method	Reference standard
Mechanical characteristics		
resistance to Soldering heat (IR reflow)	Temp./ Duration : 265°C /10sec x2 times Total time : 4min.(IR-reflow)	EIAJED-4701 -300(301)M(II)
Vibration	Total peak amplitude : 1.5mm Vibration frequency : 10 to 2000 Hz Sweep period : 20 minute Vibration directions : 3 mutually perpendicular Duration : 2 hr / direc.	MIL-STD 202G method 204
Mechanical Shock	directions : 3 impacts per axis Acceleration : 3000g's, +20/-0 % Duration : 0.3 ms (total 18 shocks) Waveform : Half-sine	MIL-STD 202G method 213
Solderability	Solder Temperature:265±5°C Duration time: 5±0.5 seconds.	J-STD-002
Environmental characteristics		
Thermal Shock	Heat cycle conditions -40 °C (30min) ↔ 85 °C (30min) * cycle time : 10 times	MIL-STD 883G method 1010.8
Humidity test	Temperature : 85 ± 2 °C Relative humidity : 85% Duration : 96 hours	MIL-STD 202G method 103
Dry heat (Aging test)	Temperature : 125 ± 2 °C Duration : 168 hours	MIL-STD 202G method 108A
Cold resistance (Low Temp Storage)	Temperature : -40 ± 2 °C Duration : 96 hours	IEC 60068-2-1