



TAI-SAW TECHNOLOGY CO., LTD.

No. 3, Industrial 2nd Rd., Ping-Chen Industrial District,
Taoyuan, 324, Taiwan, R.O.C.

TEL: 886-3-4690038 FAX: 886-3-4697532

E-mail: tstsales@mail.taisaw.com Web: www.taisaw.com

Approval Sheet For Product Specification

Issued Date: 05/30/2005

Product Name: SMD Clock Oscillator 28.800 MHz

TST Parts No.: TW0161A

Customer Parts No.: _____

Company: _____
Division: _____
Approved by : _____
Date: _____

Checked by: _____ Robert Chang

Approval by: _____ T.F. Yang

Date: _____ 2005/05/30



TAI-SAW TECHNOLOGY CO., LTD.

No. 3, Industrial 2nd Rd., Ping-Chen Industrial District,
Taoyuan, 324, Taiwan, R.O.C.

TEL: 886-3-4690038 FAX: 886-3-4697532

E-mail: tstsales@mail.taisaw.com Web: www.taisaw.com

SMD Clock Oscillator 28.800MHz

MODEL NO.: TW0161A

REV. NO.: 1

A. FEATURES:

1. Ultra small package
2. Excellent for high-density packaging.

RoHS Compliant
Lead free
Lead-free soldering

B. MAXIMUM RATING:

1. DC Voltage: 12 VDC.
2. Storage Temperature: -55 °C to +125 °C.
3. Operating Temperature: -10 °C to +70 °C.

C. ELECTRICAL CHARACTERISTICS:

Characteristics	Units	Minimum	Typical	Maximum
Center Frequency	MHz		28.8000	
Frequency Stability (#note 1)	ppm	-50	-	50
Input Voltage (Operating VDD)	VDC	-	3.3+/-10%	-
Input Current	mA	-	-	20
Output				
Load	pF	-	15	-
"0" Level	VDC	-	-	0.3
"1" Level	VDC	3.0	-	-
Symmetry (TW/T*100%) Duty Cycle	%	40%	-	60%
Rise Time (10%->90% VDD)	nSec	-	-	10
Fall Time (90%->10% VDD)	nSec	-	-	10
Enable/Disable Function		PIN 1: High or Open, PIN 3:Enable PIN 1: Low, PIN 3:Disable		
Package size		SMD5.0X7.0X1.6mm		

#Note 1: Frequency stability includes 25°C tolerance, operating temperature range, aging and voltage or load change.

D. OUTLINE DRAWING: (Unit: mm)

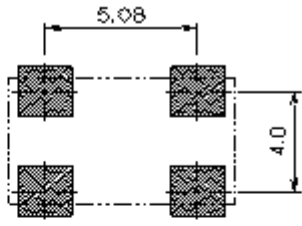

Recommended Soldering Pattern

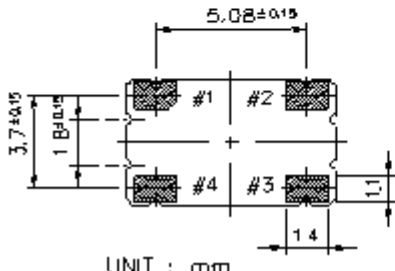

UNIT : mm

PIN#	FUNCTION
1	NO CONNECT/3-STATE
2	CIRCUIT AND COVER GROUND
3	OUTPUT
4	VDD

E. FREQUENCY STABILITY OVER TEMPERATURE (TYPICAL):

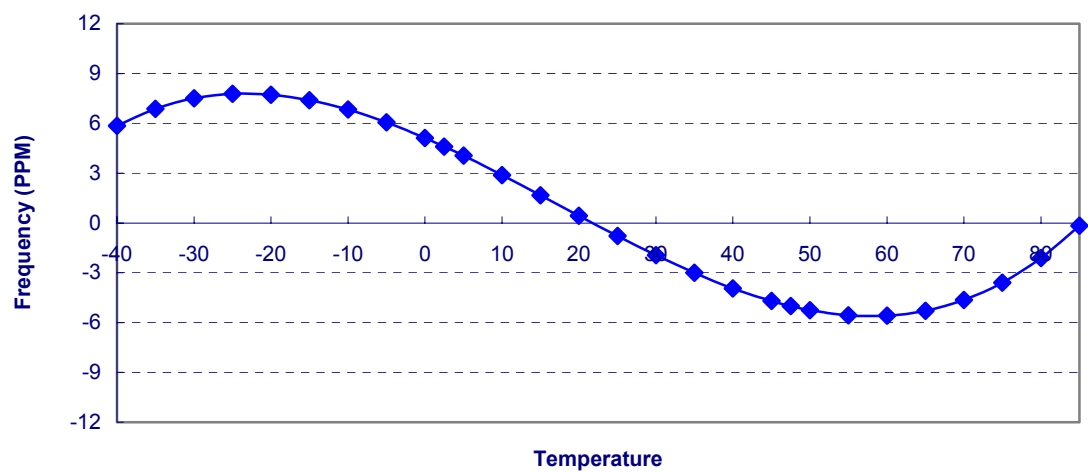

F. TEST CIRCUIT:

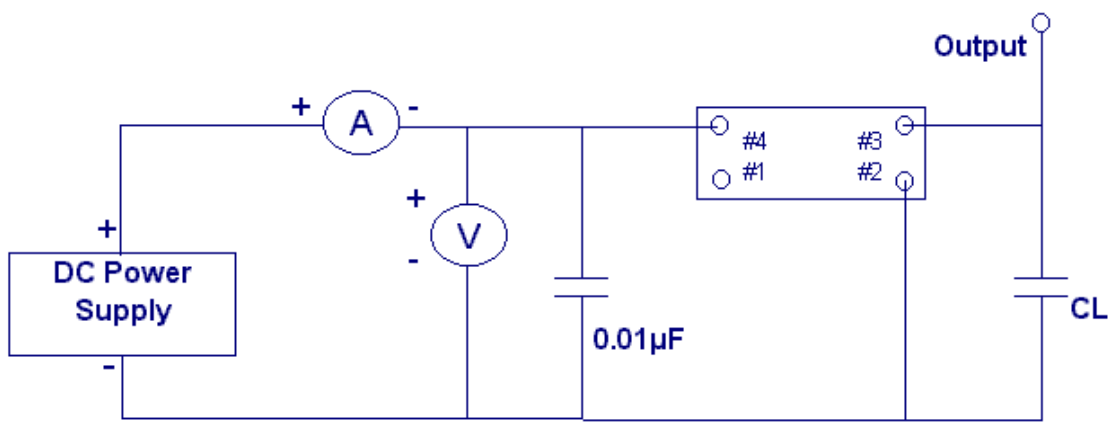

G. OUTPUT WAVEFORM (TYPICAL):

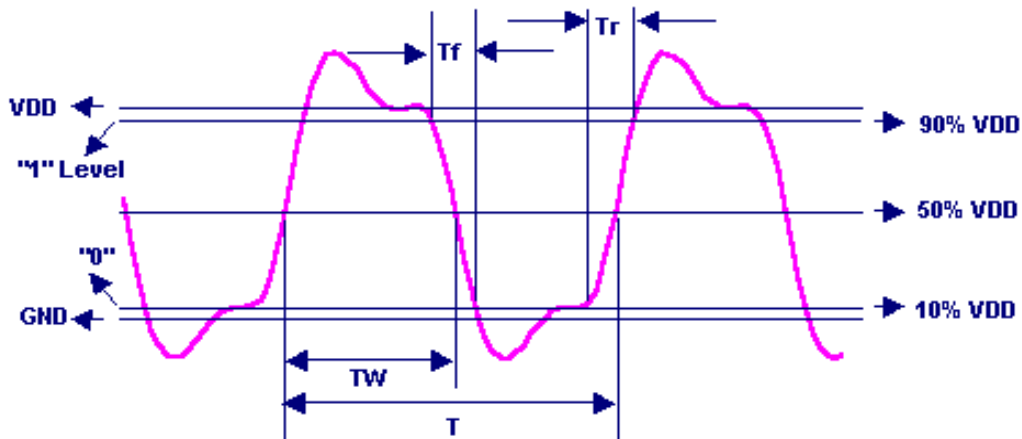

H. SOLDERING REFLOW PROFILE:

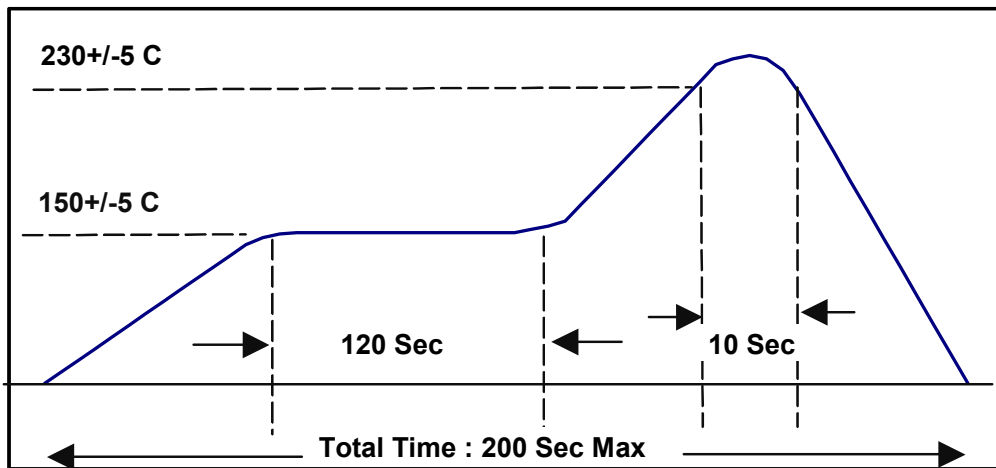

I. MARKING:

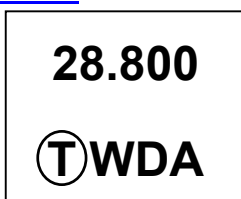

Where W stand for product code and D for date code

1. Product Code Table:

Year	2001 2005	2002 2006	2003 2007	2004 2008
Product Code	W	w	<u>W</u>	<u>w</u>

2. Date Code Table:

WK01	WK02	WK03	WK04	WK05	WK06	WK07	WK08	WK09	WK10	WK11	WK12	WK13
A	B	C	D	E	F	G	H	I	J	K	L	M
WK14	WK15	WK16	WK17	WK18	WK19	WK20	WK21	WK22	WK23	WK24	WK25	WK26
N	O	P	Q	R	S	T	U	V	W	X	Y	Z
WK27	WK28	WK29	WK30	WK31	WK32	WK33	WK34	WK35	WK36	WK37	WK38	WK39
a	b	c	d	e	f	g	h	i	j	k	l	m
WK40	WK41	WK42	WK43	WK44	WK45	WK46	WK47	WK48	WK49	WK50	WK51	WK52
n	o	p	q	r	s	t	u	v	w	x	y	z

J. PACKING:

1. REEL DIMENSION (Unit: mm)

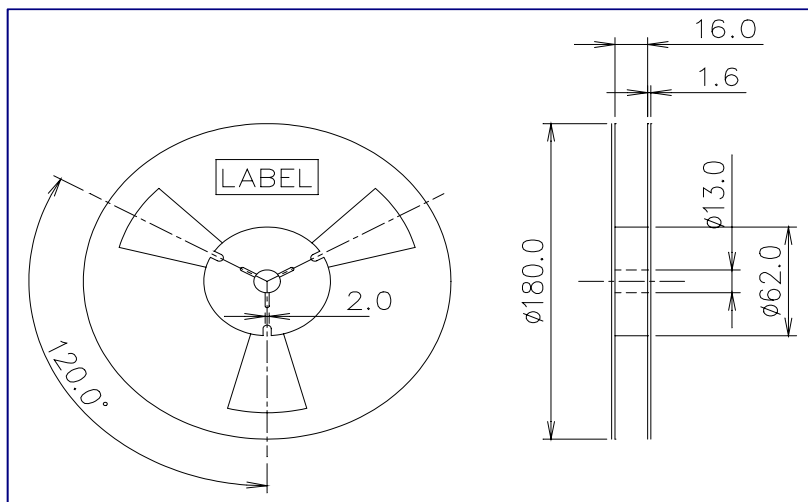

2. TAPE DIMENSION (Unit: mm)

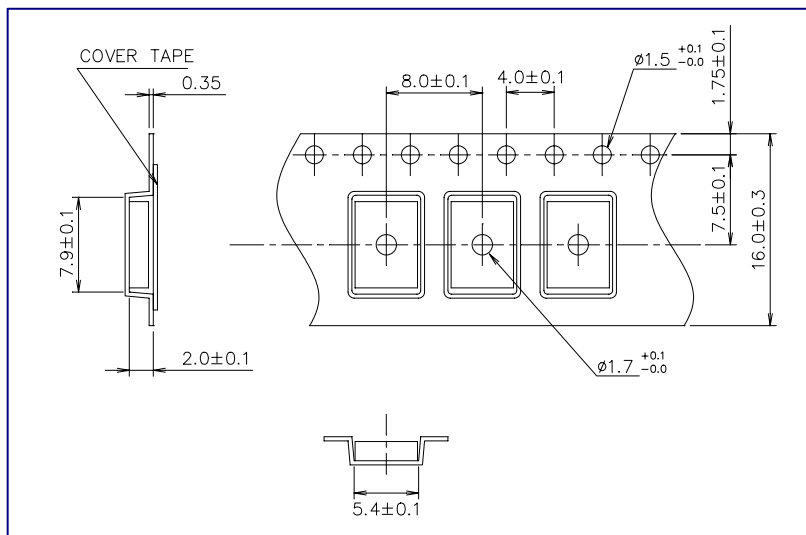

3. PACKING DIRECTION

The dot or the logo of marking should be close to the hole of tape.