



TAI-SAW TECHNOLOGY CO., LTD.

No. 3, Industrial 2nd Rd., Ping-Chen Industrial District,
Taoyuan, 324, Taiwan, R.O.C.

TEL: 886-3-4690038 FAX: 886-3-4697532

E-mail: tstsales@mail.taisaw.com Web: www.taisaw.com

Approval Sheet For Product Specification

Issued Date: 11/6/2007 (REV. NO: 1)

Product Name: SMD 5.0x3.2 10MHz Crystal Oscillator

TST Parts No.: TW0280A

Customer Parts No. : _____

| |
|--------------------|
| Company: _____ |
| Division: _____ |
| Approved by: _____ |
| Date: _____ |

Checked by: _____ Ryan Huang

Approval by: _____ Robert Chang

Date: _____ 11/6/2007



TAI-SAW TECHNOLOGY CO., LTD.

No. 3, Industrial 2nd Rd., Ping-Chen Industrial District,
Taoyuan, 324, Taiwan, R.O.C.

TEL: 886-3-4690038 FAX: 886-3-4697532

E-mail: tstsales@mail.taisaw.com Web: www.taisaw.com

SMD 5.0x3.2 10MHz Crystal Oscillator

MODEL NO.: TW0280A

REV. NO: 1

Features:

- Surface Mount Seam Weld Package
- Excellent Reliability Performance
- Good Frequency Perturbation and Stability over temperature

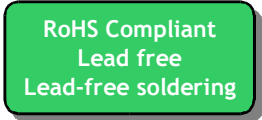

Application:

- 5.0 V Supply Voltage Operation / CMOS Output
- Option-able stand-by function for output.

Electrical Characteristics:

| TW0280A | Specifications |
|--|--|
| Nominal Frequency, Fo | 10.000000 MHz |
| Storage Temperature Range | -40°C to +85°C |
| Operating Temperature Range | -10°C to +70°C |
| Power Supply Voltage, Vcc | 5.0 V +/- 5% |
| Load | 15pF |
| “0” Level “1” Level | 0.5 V max 4.5 V min |
| Power Supply Current, Icc | 20 mA max |
| Frequency Accuracy ¹ | +/-20 ppm max |
| Duty Cycle | 40% ~ 60% |
| Rise Time (10% -> 90% of final RF level in Vp-p) Fall Time (90% -> 10% of final RF level in Vp-p) | 20 nsec max. 20 nsec max |
| Enable/Disable Function | PIN 1: High or Open, PIN 3:Enable PIN 1: Low, PIN 3:Disable |

#Note 1: Frequency accuracy includes 25C tolerance, operating temperature range -10 to 70 deg C, aging and voltage or load change

Mechanical Dimensions: (Unit: mm)

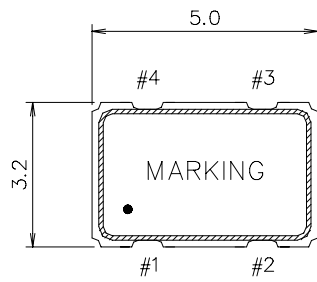

UNIT: mm

| PIN# | FUNCTION |
|------|--------------------------|
| 1 | NO CONNECT/3-STATE |
| 2 | CIRCUIT AND COVER GROUND |
| 3 | OUTPUT |
| 4 | VDD |

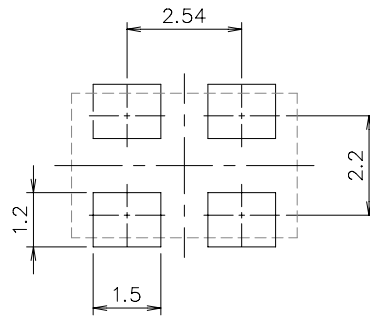
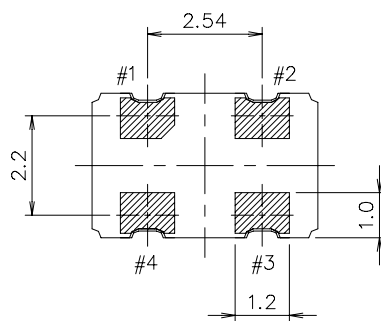
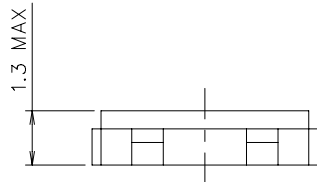

Recommended Soldering Pattern

Test Circuit:

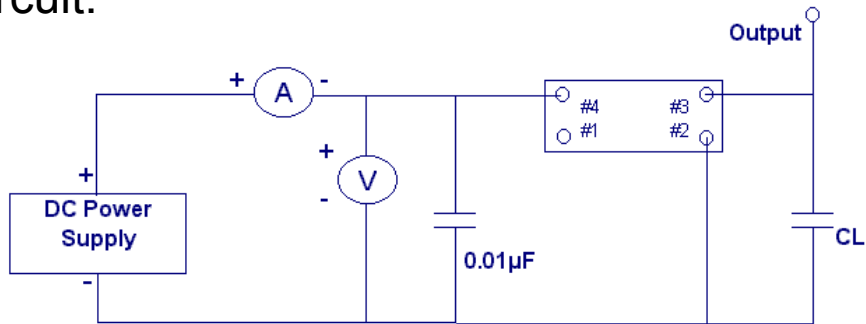

Output Waveform :

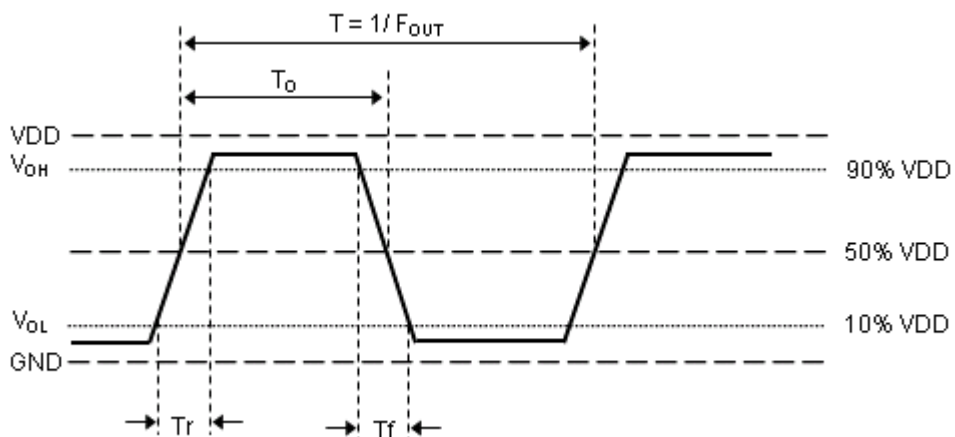

Marking:

Line 1: 10.000(Frequency)

Line 2: $\text{\textcircled{T}}$ WDA (TST logo + Product Code + Data Code + TST Internal Code)

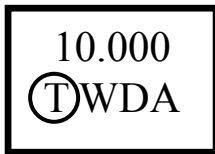

Product Code Table

| Year | 2001 2005 | 2002 2006 | 2003 2007 | 2004 2008 |
|--------------|--------------|--------------|--------------|--------------|
| Product Code | W | w | <u>W</u> | <u>w</u> |

Date Code Table

| | | | | | | | | | | | | |
|------|------|------|------|------|------|------|------|------|------|------|------|------|
| WK01 | WK02 | WK03 | WK04 | WK05 | WK06 | WK07 | WK08 | WK09 | WK10 | WK11 | WK12 | WK13 |
| A | B | C | D | E | F | G | H | I | J | K | L | M |
| WK14 | WK15 | WK16 | WK17 | WK18 | WK19 | WK20 | WK21 | WK22 | WK23 | WK24 | WK25 | WK26 |
| N | O | P | Q | R | S | T | U | V | W | X | Y | Z |
| WK27 | WK28 | WK29 | WK30 | WK31 | WK32 | WK33 | WK34 | WK35 | WK36 | WK37 | WK38 | WK39 |
| a | b | c | d | e | f | g | h | i | j | k | l | m |
| WK40 | WK41 | WK42 | WK43 | WK44 | WK45 | WK46 | WK47 | WK48 | WK49 | WK50 | WK51 | WK52 |
| n | o | p | q | r | s | t | u | v | w | x | y | z |

Packing:

■ Reel Dimension (Unit: mm)

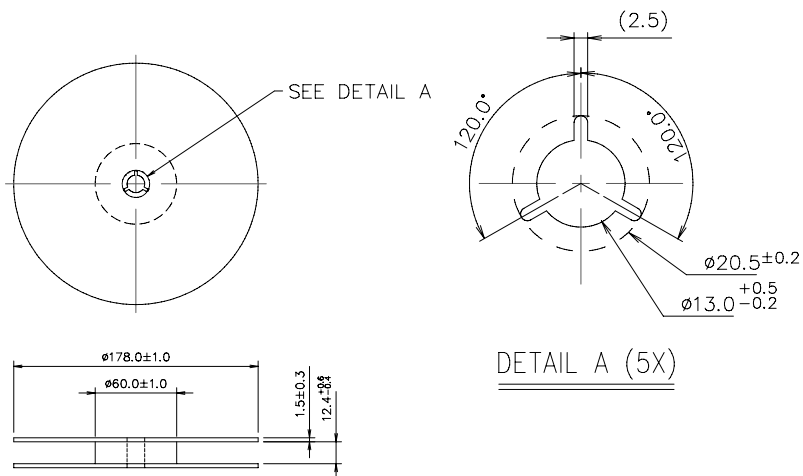

■ Tape Dimension (Unit: mm)

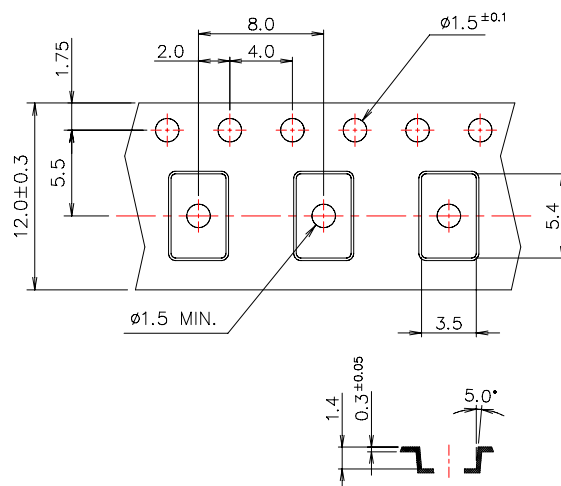

[NOTE]:

1. Unless otherwise specified tolerance on dimension +/-0.1 mm.
2. Material: conductive polystyrene with color black
3. 10 pitch cumulative tolerance +/-0.2 mm.
4. Packing Direction: dot or the logo of marking should be close to the hole of tape.

■ **PACKING DIRECTION:**

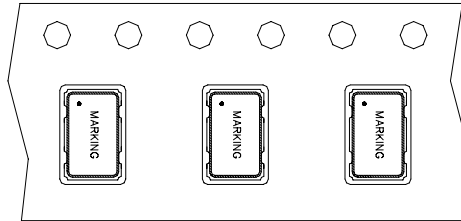

Reflow Profile:

