



TAI-SAW TECHNOLOGY CO., LTD.

No. 3, Industrial 2nd Rd., Ping-Chen Industrial District,
Taoyuan, 324, Taiwan, R.O.C.

TEL: 886-3-4690038 FAX: 886-3-4697532

E-mail: tstsales@mail.taisaw.com Web: www.taisaw.com

Approval Sheet For Product Specification

Issued Date: 2007/11/7 (REV NO : 1)

Product Name: 7.0x5.0 XO 100 MHz PECL Output Oscillator

TST Parts No.: TW0283A

Customer Parts No.: _____

Company: _____
Division: _____
Approved by : _____
Date: _____

Checked by: _____ Ryan Huang

Approval by: _____ Robert Chang

Date: _____ 2007/11/7



TAI-SAW TECHNOLOGY CO., LTD.

No. 3, Industrial 2nd Rd., Ping-Chen Industrial District,
Taoyuan, 324, Taiwan, R.O.C.

TEL: 886-3-4690038 FAX: 886-3-4697532

E-mail: tstsales@mail.taisaw.com Web: www.taisaw.com

7.0x5.0 100 MHz PECL Output Oscillator

MODEL NO.: TW0283A

REV. NO.: 1

Features:

- 3.3V Operation / Complementary PECL Output
- Enable / Disable Tristate Function (6-Pad)
- Main application: WLAN, SONET/SDH/DWDM, Gigabite Ethernet, Storage Area Network, Digital Video

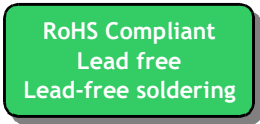

Electrical Specifications:

Measurement shall be made under room temperature and humidity at below conditions.

Temperature: 25+/-3 °C

Humidity: Below 70% RH

Operating Temperature: 0 °C to +70 °C

Storage Temperature: -40 °C to +85 °C

Characteristics	Units	Minimum	Typical	Maximum
Center Frequency	MHz		100	
* Frequency Stability	ppm	-100	-	100
Poser Supply Voltage	VDC	-	3.3+/-5%	-
Power Supply Current	mA	-	-	100
Output				
Load	ohm	-	50	-
Output Low (Logic "0")	VDC	-	-	Vdd-1.620
Output High (Logic "1")	VDC	Vdd-1.025	-	-
Duty Cycle	%	45%	50%	55%
Rise Time (10%->90% VDD)	nSec	-	0.6	1.5
Fall Time (90%->10% VDD)	nSec	-	0.6	1.5
Enable/Disable Function		PIN#2: High or Open , PIN#4: Enable PIN#2: Low , PIN#4: Disable		
Package size		SMD7.0x5.0x1.8mm		

Parameter denoted with an asterisk(*)

* Note1 : Frequency stability includes 25°C tolerance, operating temperature range, aging and input voltage or load change.

Mechanical Dimensions (mm):

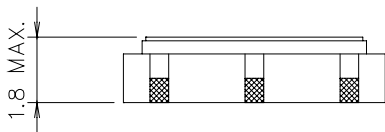
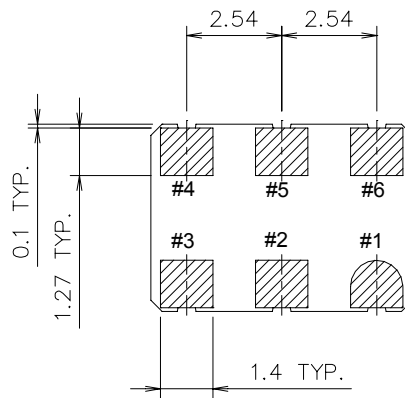
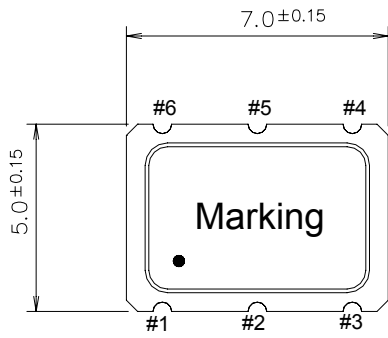

Pin Connection

- #1 OE
- #2 No Connection
- #3 GND
- #4 Output 1 (Q)
- #5 Output 2 (Qbar)
- #6 VDD

Marking:

Line 1: 100.00 (Frequency)

Line 2: $\text{\textcircled{T}}$ WDA (TST logo + Product Code + Data Code + TST Internal Code)

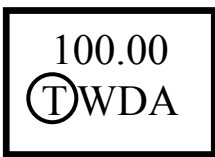

Product Code Table

Year	2001 2005	2002 2006	2003 2007	2004 2008
Product Code	W	w	<u>W</u>	<u>w</u>

Date Code Table

WK01	WK02	WK03	WK04	WK05	WK06	WK07	WK08	WK09	WK10	WK11	WK12	WK13
A	B	C	D	E	F	G	H	I	J	K	L	M
WK14	WK15	WK16	WK17	WK18	WK19	WK20	WK21	WK22	WK23	WK24	WK25	WK26
N	O	P	Q	R	S	T	U	V	W	X	Y	Z
WK27	WK28	WK29	WK30	WK31	WK32	WK33	WK34	WK35	WK36	WK37	WK38	WK39
a	b	c	d	e	f	g	h	i	j	k	l	m
WK40	WK41	WK42	WK43	WK44	WK45	WK46	WK47	WK48	WK49	WK50	WK51	WK52
n	o	p	q	r	s	t	u	v	w	x	y	z

Tape & Reel:

- Packing Quantity: 1k /Reel
- Reel dimension (unit: mm)

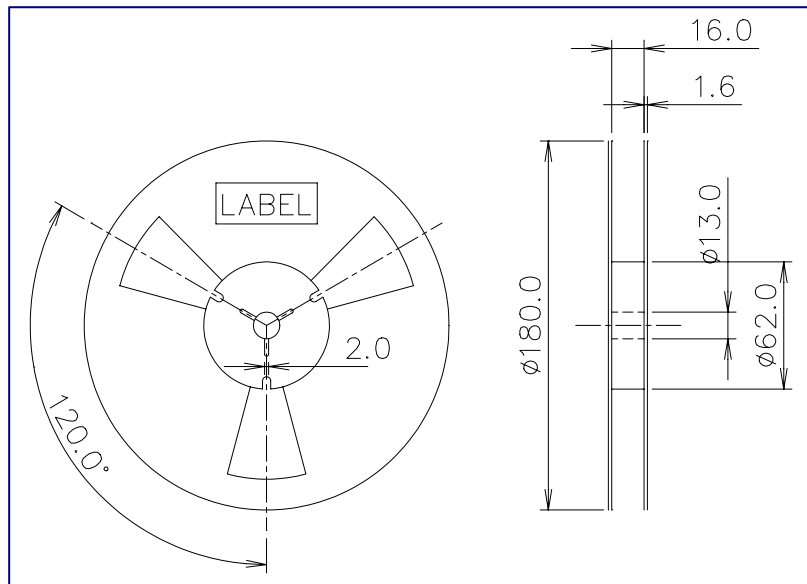

- Tape dimension (unit: mm)

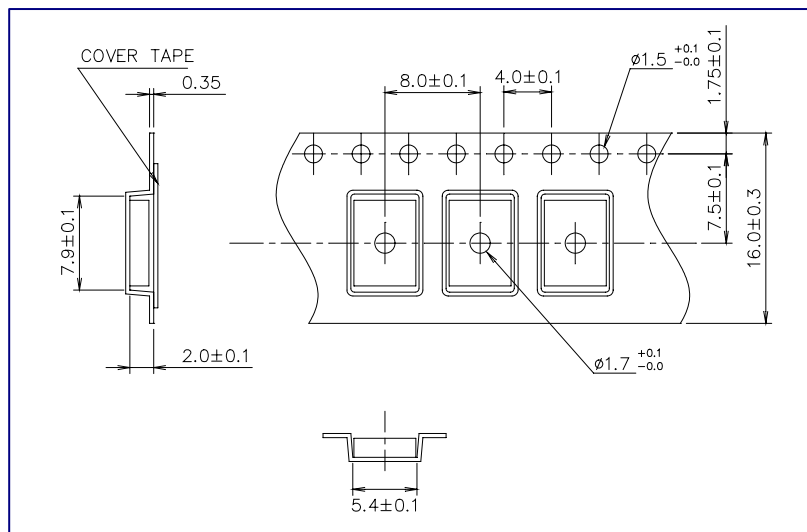

- Packing direction

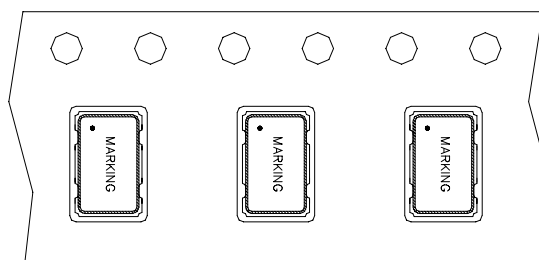

Reflow Profile:

