



# TAI-SAW TECHNOLOGY CO., LTD.

No. 3, Industrial 2nd Rd., Ping-Chen Industrial District,  
Taoyuan, 324, Taiwan, R.O.C.

TEL: 886-3-4690038 FAX: 886-3-4697532

E-mail: [tstsales@mail.taisaw.com](mailto:tstsales@mail.taisaw.com) Web: [www.taisaw.com](http://www.taisaw.com)

## Product Specifications Approval Sheet

Product Description: Crystal Oscillator SMD 5.0x3.2 12.288MHz

TST Part No.: TW0326A

Customer Part No.: \_\_\_\_\_

Customer signature required
Company: _____
Division: _____
Approved by : _____
Date: _____

Checked by: \_\_\_\_\_ Quinton Lo *Quinton Lo*

Approved by: \_\_\_\_\_ Robert Chang *Robert Chang*

Date: \_\_\_\_\_ 10/29/2009

1. Customer signed back is required before TST can proceed with sample build and receive orders.
2. Orders received without customer signed back will be regarded as agreement on the specifications.
3. Any specifications changes must be approved upon by both parties and a new revision of specifications shall be released to reflect the changes.



**TAI-SAW TECHNOLOGY CO., LTD.**  
**SMD 5.0x3.2 12.288MHz Crystal Oscillator**

MODEL NO.: TW0326A

REV. NO.: 1

**Revise:**

Rev.	Rev. Page	Rev. Account	Date	Ref. No.	Reviser
1	N/A	Initial release	10/29/09'	N/A	Quinton Lo



# TAI-SAW TECHNOLOGY CO., LTD.

No. 3, Industrial 2nd Rd., Ping-Chen Industrial District,  
Taoyuan, 324, Taiwan, R.O.C.

TEL: 886-3-4690038 FAX: 886-3-4697532

E-mail: [tstsales@mail.taisaw.com](mailto:tstsales@mail.taisaw.com) Web: [www.taisaw.com](http://www.taisaw.com)

## SMD 5.0x3.2 12.288MHz Crystal Oscillator

MODEL NO.: TW0326A

REV. NO: 1.0

### Features:

- Surface Mount Seam Weld Package
- Excellent Reliability Performance
- Good Frequency Perturbation and Stability over temperature

RoHS Compliant  
Lead free  
Lead-free soldering

### Application:

- 3.3 V Supply Voltage CMOS Output
- Option-able stand-by function for output.

### Electrical Characteristics:

TW0326A	Specifications
Nominal Frequency, Fo	12.288 MHz
Storage Temperature Range	-55°C to +125°C
Operating Temperature Range	-10°C to +70°C
Power Supply Voltage, Vcc	3.3 V +/- 10%
Load	15pF
“0” Level “1” Level	0.33 V max 2.97 V min
Power Supply Current, Icc	15 mA max
Frequency Accuracy <sup>1</sup>	+/-100 ppm max
Duty Cycle	40% ~ 60%
Rise Time ( 10% -> 90% of final RF level in Vp-p ) Fall Time ( 90% -> 10% of final RF level in Vp-p )	10 nsec max. 10 nsec max.
Aging	+/-5ppm/year
Enable/Disable Function	PIN 1: High or Open, PIN 3:Output Enable PIN 1: Low, PIN 3:Output Disable

#Note 1: Frequency accuracy includes 25C tolerance, operating temperature range -10 to 70 deg C, aging and voltage or load change

# Mechanical Dimensions: (Unit: mm)

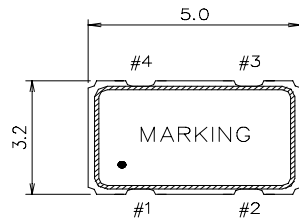

UNIT: mm

PIN# FUNCTION

1	NO CONNECT/3-STATE
2	CIRCUIT AND COVER GROUND
3	OUTPUT
4	VDD

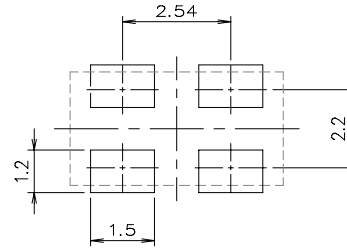
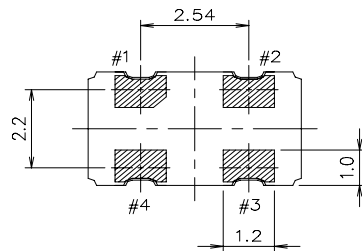
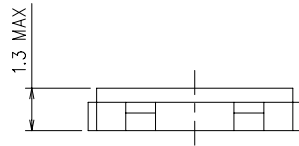

Recommended Soldering Pattern

## Test Circuit:

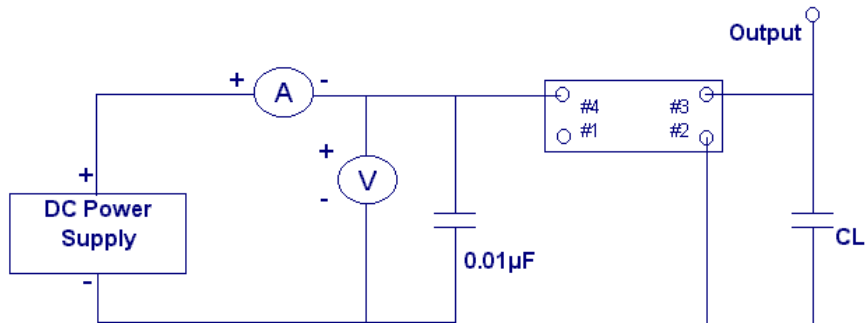

## Output Waveform :

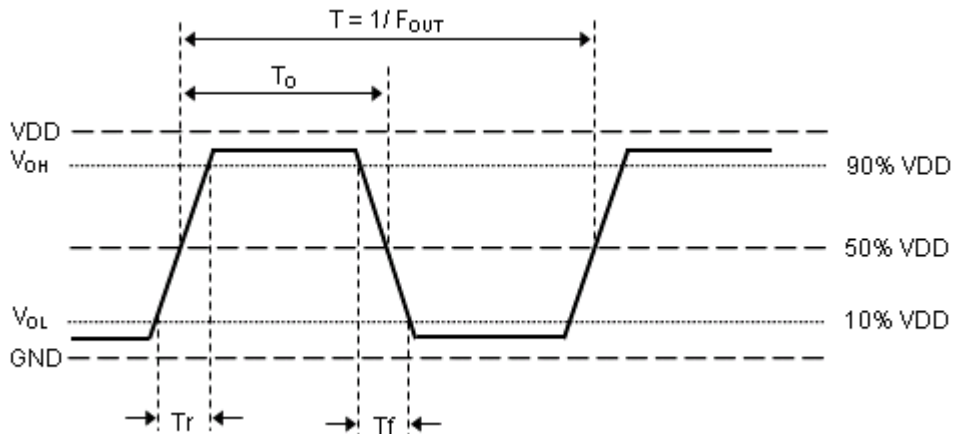

# Marking:

Line 1: 12.288(Frequency)

Line 2:  $\text{\textcircled{T}}$ WDA (TST logo + Product Code + Data Code + TST Internal Code)

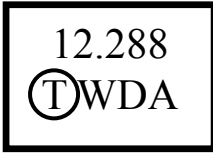

## Product Code Table

Year	2008	2009	2010	2011
	2012	2013	2014	2015
Product code	<u>w</u>	W	w	<u>W</u>

## Date Code Table

WK01	WK02	WK03	WK04	WK05	WK06	WK07	WK08	WK09	WK10	WK11	WK12	WK13
A	B	C	D	E	F	G	H	I	J	K	L	M
WK14	WK15	WK16	WK17	WK18	WK19	WK20	WK21	WK22	WK23	WK24	WK25	WK26
N	O	P	Q	R	S	T	U	V	W	X	Y	Z
WK27	WK28	WK29	WK30	WK31	WK32	WK33	WK34	WK35	WK36	WK37	WK38	WK39
a	b	c	d	e	f	g	h	i	j	k	l	m
WK40	WK41	WK42	WK43	WK44	WK45	WK46	WK47	WK48	WK49	WK50	WK51	WK52
n	o	p	q	r	s	t	u	v	w	x	y	z

# Packing:

## 1. Reel Dimension (Unit: mm)

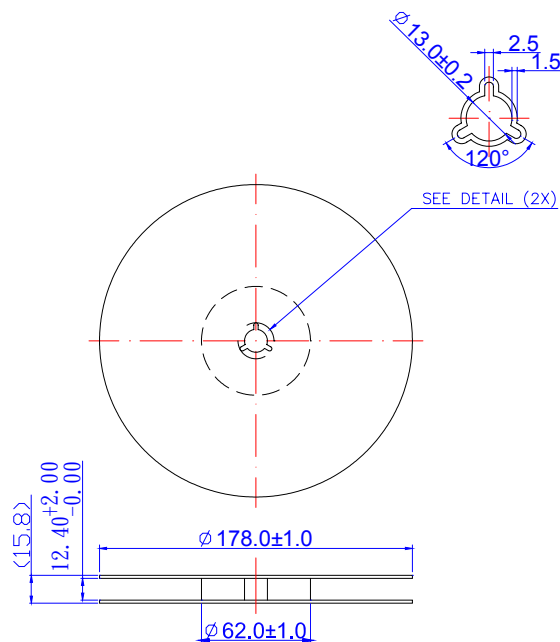

## 2. Tape Dimension (Unit: mm)

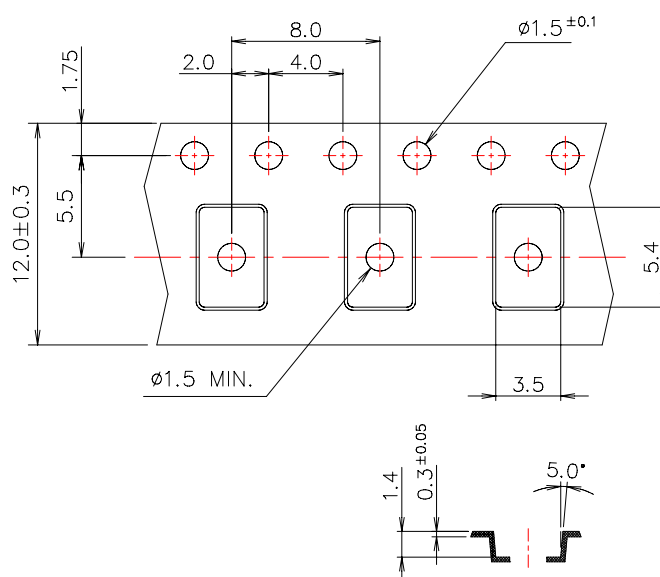

### [NOTE]:

1. Unless otherwise specified tolerance on dimension  $\pm 0.1$  mm.
2. Material: conductive polystyrene with color black
3. 10 pitch cumulative tolerance  $\pm 0.2$  mm.
4. Packing Direction: dot or the logo of marking should be close to the hole of tape.

## 3. PACKING DIRECTION:

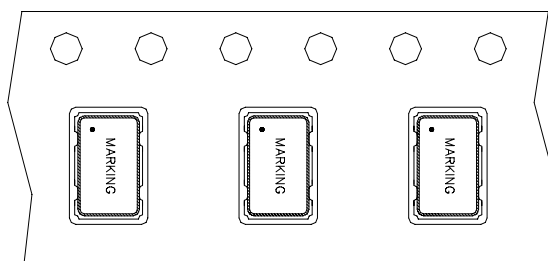

## Packing Quantity/Packing:

1K pcs maximum per reel

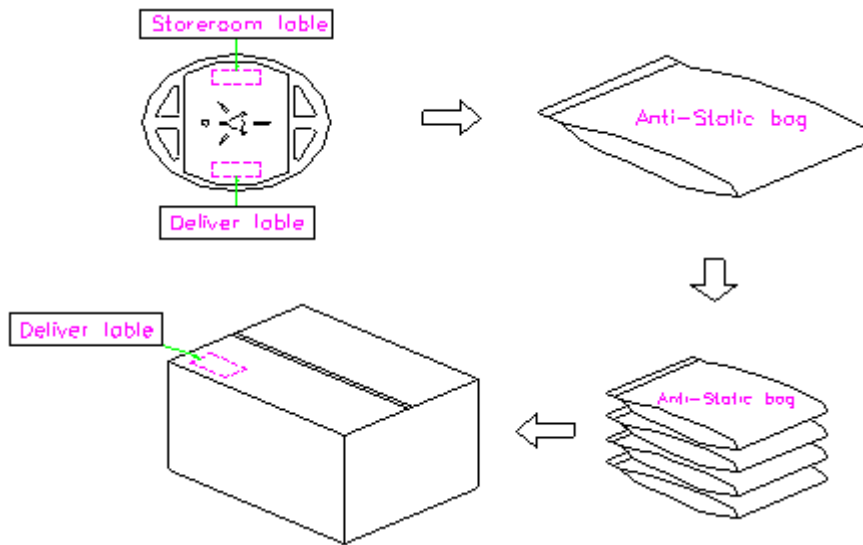

## Reflow Profile:

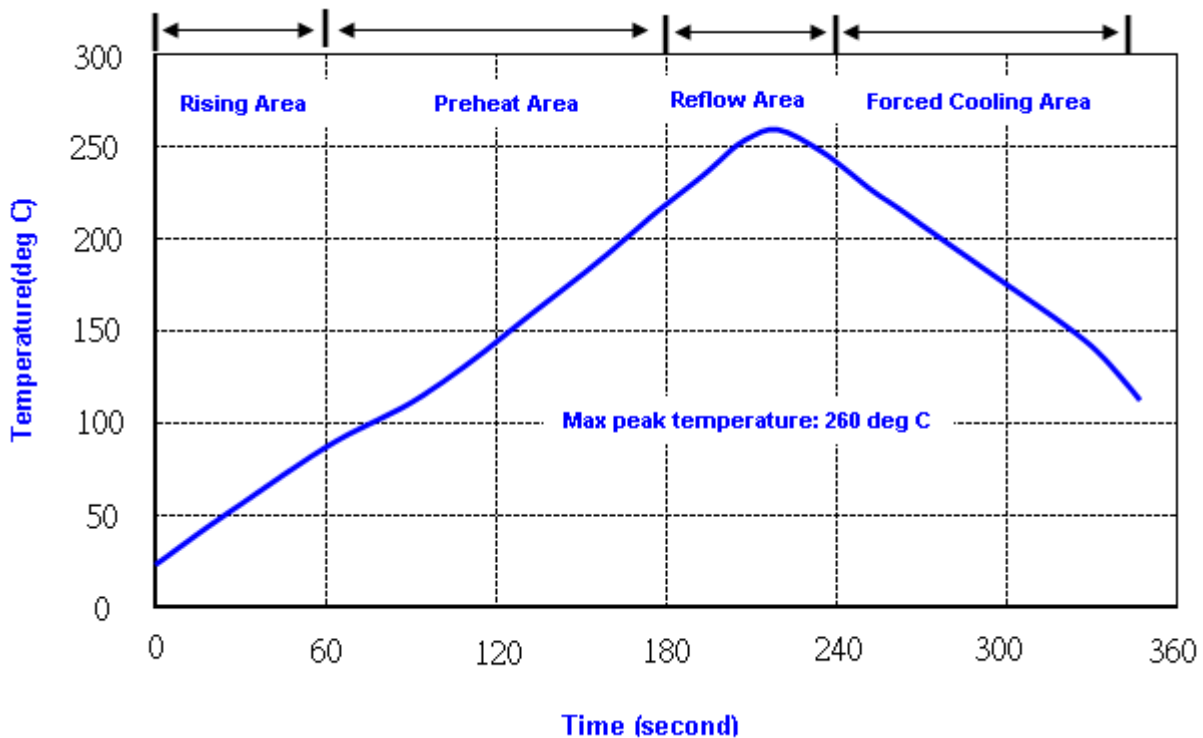

- Note: 1. Max peak temperature: 260 $\pm$ 5 deg C; Time: 10 $\pm$ 2 sec  
 2. Temperature: 217 $\pm$ 5 deg C; Time: 90~100 sec

## Reliability Specifications

Test name	Test process / method	Reference standard
<b>Mechanical characteristics</b>		
resistance to Soldering heat (IR reflow)	Temp./ Duration : 260°C /10sec ×2 times Total time : 4min.(IR-reflow)	EIAJED-4701 -300(301)M(II)
Vibration	Total peak amplitude : 1.5mm Vibration frequency : 10 to 55 Hz Sweep period : 1.0 minute Vibration directions : 3 mutually perpendicular Duration : 2 hr / direc.	MIL-STD 202F method 201A
Mechanical Shock	directions : 3 impacts per axis Acceleration : 3000g's, +20/-0 % Duration : 0.3 ms (total 18 shocks) Waveform : Half-sine	MIL-STD 202F method 213C
Solderability	Solder Temperature:265±5°C Duration time: 5±0.5 seconds.	MIL-STD 883G method 2003
<b>Environmental characteristics</b>		
Thermal Shock	Heat cycle conditions -55 °C (30min) ↔ 125 °C (30min) * cycle time : 10 times	MIL-STD 883G method 1010.7
Humidity test	Temperature : 70 ± 2 °C Relative humidity : 90~95% Duration : 96 hours	MIL-STD 202F method 103B
Dry heat ( Aging test )	Temperature : 125 ± 2 °C Duration : 168 hours	MIL-STD 883G method 1008.2 condition C
PCT test	Pressure: 2.06kg/cm <sup>2</sup> (2.03*10 <sup>5</sup> pa) Temperature : 121 ± 2 °C Relative humidity : 100% Duration : 24 hours	EIAJED-4701-3 B-123A