



TAI-SAW TECHNOLOGY CO., LTD.

No. 3, Industrial 2nd Rd., Ping-Chen Industrial District,
Taoyuan, 324, Taiwan, R.O.C.

TEL: 886-3-4690038 FAX: 886-3-4697532

E-mail: tstsales@mail.taisaw.com Web: www.taisaw.com

Approval Sheet For Product Specification

Issued Date: 2007/3/15 (REV NO.: 1.0)

Product Name: 7.0x5.0 VCXO 35.328 MHz

TST Parts No.: TX0158A

Customer Parts No.: _____

Company: _____
Division: _____
Approved by : _____
Date: _____

Checked by: _____ Ryan Huang

Approval by: _____ Robert Chang

Date: _____ 2007/3/15



TAI-SAW TECHNOLOGY CO., LTD.

No. 3, Industrial 2nd Rd., Ping-Chen Industrial District,
Taoyuan, 324, Taiwan, R.O.C.

TEL: 886-3-4690038 FAX: 886-3-4697532

E-mail: tstsales@mail.taisaw.com Web: www.taisaw.com

7.0x5.0 VCXO 35.328 MHz

MODEL NO.: TX0158A

REV. NO.:1.0

Features:

1. 3.3V Supply
2. Low Cost for Volume Applications
3. Enable / Disable Tristate Function (6-Pad)

RoHS Compliant
Lead free
Lead-free soldering

Electrical Specifications:

Measurement shall be made under room temperature and humidity at below conditions.

Temperature: 25+/-3 °C

Humidity: Below 70% RH

Operating Temperature: -10 °C to +70 °C

Storage Temperature: -40 °C to +85 °C

Characteristics	Units	Minimum	Typical	Maximum
Center Frequency	MHz		35.328	
Frequency Stability (#note 1)	ppm	-50	-	50
Input Voltage (Operating Vdd)	VDC	-	3.3+/-5%	-
Input Current	mA	-	-	20
Control Voltage (Vt)	VDC	0.3	1.65	3.0
Frequency Pullability	ppm	+/-100	-	-
Linearity	%		10%	
Output				
Load	pF	-	15	-
"0" Level	VDC	-	-	0.33
"1" Level	VDC	2.97	-	-
Symmetry (Duty Cycle)	%	40%	-	60%
Rise Time (10%->90% VDD)	nSec	-	-	5
Fall Time (90%->10% VDD)	nSec	-	-	5
Enable/Disable Function		PIN#2: High or Open, PIN#4:Enable PIN#2: Low, PIN#4:Disable		
Package size		SMD7.0x5.0x1.8mm		

#Note 1: Frequency stability includes 25°C tolerance, operating temperature range, aging and voltage or load change.

Mechanical Dimensions (mm):

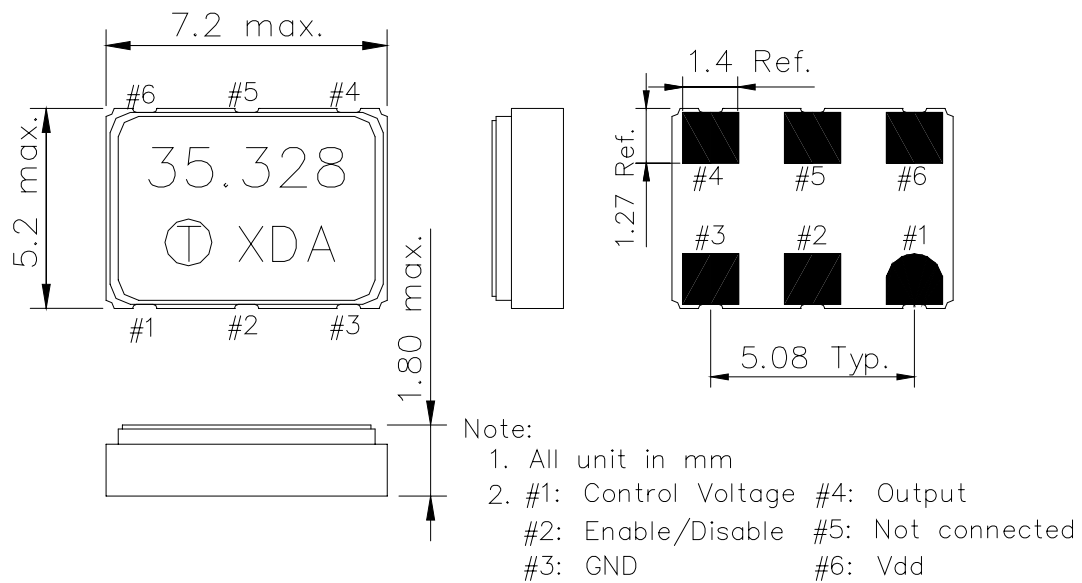

Marking:

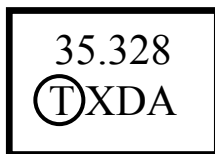

Line 1: 35.328 (Frequency)

Line 2: ⓉXDA(TST logo + Product Code + Data Code + TST Internal Code)

■ Product Code Table:

Year	2001	2002	2003	2004
	2005	2006	2007	2008
Product Code	X	x	<u>X</u>	<u>x</u>

■ Date Code Table:

WK01	WK02	WK03	WK04	WK05	WK06	WK07	WK08	WK09	WK10	WK11	WK12	WK13
A	B	C	D	E	F	G	H	I	J	K	L	M
WK14	WK15	WK16	WK17	WK18	WK19	WK20	WK21	WK22	WK23	WK24	WK25	WK26
N	O	P	Q	R	S	T	U	V	W	X	Y	Z
WK27	WK28	WK29	WK30	WK31	WK32	WK33	WK34	WK35	WK36	WK37	WK38	WK39
a	b	c	d	e	f	g	h	i	j	k	l	m
WK40	WK41	WK42	WK43	WK44	WK45	WK46	WK47	WK48	WK49	WK50	WK51	WK52
n	o	p	q	r	s	t	u	v	w	x	y	z

Tape & Reel: Packing Quantity: 1k /Reel

REEL DIMENSION (unit: mm)

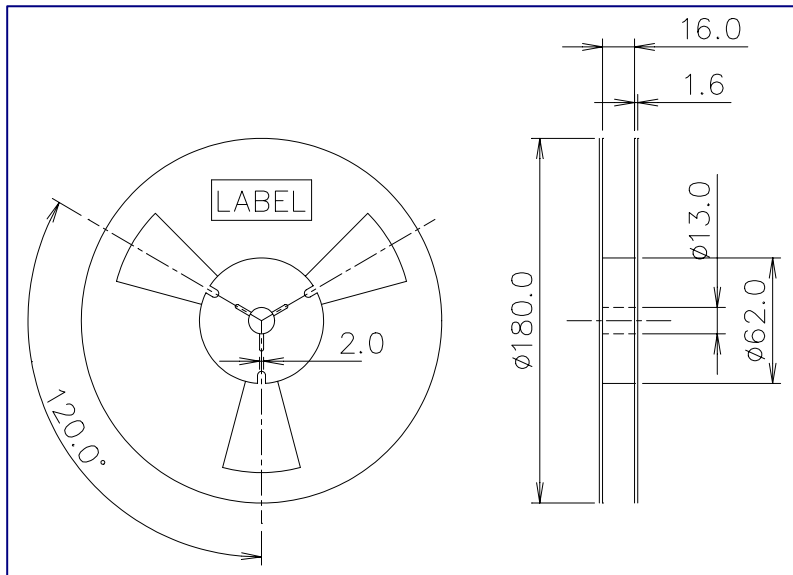

TAPE DIMENSION (unit: mm)

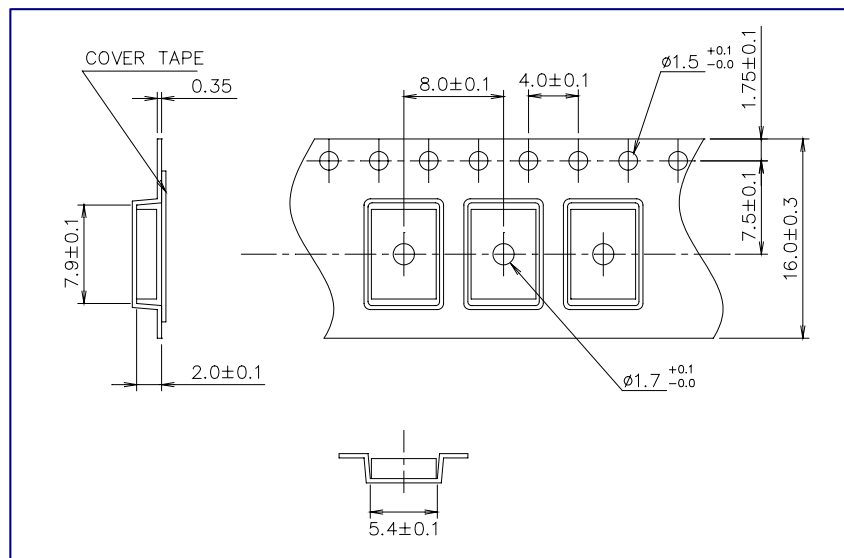

PACKING DIRECTION

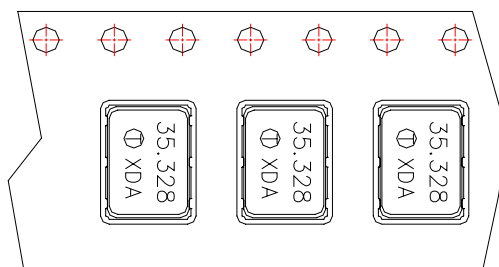

Reflow Profile:

