



TAI-SAW TECHNOLOGY CO., LTD.

No. 3, Industrial 2nd Rd., Ping-Chen Industrial District,
Taoyuan, 324, Taiwan, R.O.C.

TEL: 886-3-4690038 FAX: 886-3-4697532

E-mail: ttsales@mail.taisaw.com Web: www.taisaw.com

Product Specifications Approval Sheet

Product Name: VCTCXO 3.2x2.5mm 10.0000MHz

TST Part No.: TX0329A

Customer Part No.:

Company: _____
Division: _____
Approved by: _____
Date: _____

Checked by: CC Hsu *CC Hsu*

Approved by: Kelly Huang *Kelly Huang*

Date: 10/25/2010

1. Customer signed back is required before TST can proceed with sample build and receive orders.
2. Orders received without customer signed back will be regarded as agreement on the specifications.
3. Any specifications changes must be approved upon by both parties and a new revision of specifications shall be released to reflect the changes.



TAI-SAW TECHNOLOGY CO., LTD.
VCTCXO 3.2x2.5mm 10.0000MHz

MODEL NO.: TX0329A

REV. NO.: 1

Revise:

Rev.	Rev. Page	Rev. Account	Date	Ref. No.	Revised by
1	N/A	Initial release	10/28/10'	N/A	C.C. Hsu



TAI-SAW TECHNOLOGY CO., LTD.

No. 3, Industrial 2nd Rd., Ping-Chen Industrial District,
Taoyuan, 324, Taiwan, R.O.C.

TEL: 886-3-4690038 FAX: 886-3-4697532

E-mail: tstsales@mail.taisaw.com Web: www.taisaw.com

VCTCXO 3.2x2.5mm 10.0000MHz

MODEL NO.: TX0329A

REV. NO.: 1

Features:

- Good Frequency Stability
- Good Phase Noise Response

RoHS Compliant
Lead free
Lead-free soldering

Description and Applications:

3.2x2.5 mm VCTCXO for use in wireless communications devices

Electrical Specifications:

TX0329A	Specifications
Nominal Frequency, Fo	10.000000 MHz
Storage Temperature Range	-40°C to +85°C
Operating Temperature Range	-30°C to +85°C
Power Supply Voltage, Vcc	3.3 V +/- 5%
Output Voltage with Load 10pF//10KΩ, Vout	0.8 Vp-p min
Output Waveform	Clipped Sinewave
Control Voltage, Vcon	1.5 +/- 1.0 V
Vcon Frequency Control Range (1.5+/-1.0 V)	+/-6 ppm/V min
Power Supply Current, Icc	2.0 mA max
Frequency Tolerance after two reflows (Vcon=1.5V)	+/- 1.5 ppm max @ 25°C +/- 2°C
Frequency Stability	
a. Vs. Temperature (-30~85°C)	+/- 2.5 ppm reference to 25°C
b. Vs. Load varied 10pF//10KΩ+/-10%	+/- 0.2 ppm
c. Vs. Supply Voltage varied 3.3V+/-5%	+/- 0.2 ppm
Start Up Time (90% of final RF level in Vp-p)	2.0 msec max.
Harmonics	-5.0 dBc max
Aging	+/-1.0 ppm/year @25°C
SSB Phase Noise (@1KHz Carrier Offset)	-130 dBc/Hz max

Mechanical Dimensions (mm):

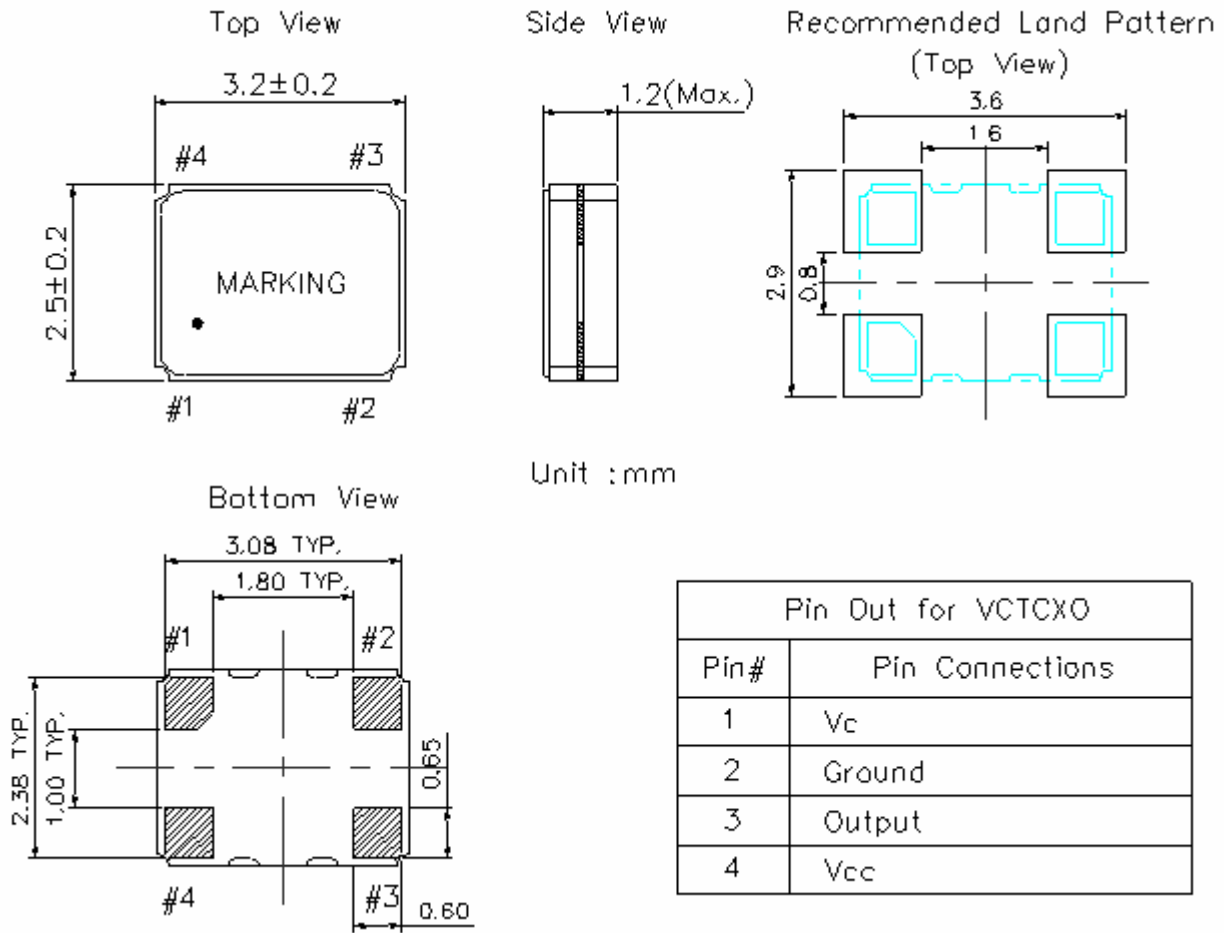

Marking:

Line 1: Customer Frequency (10.00)

Line 2: TST Logo + Crystal Product Code + Date Code

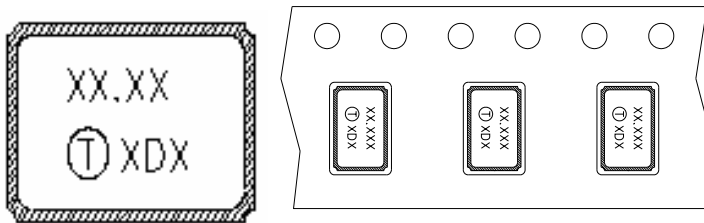

Product Code Table

Year	2005 2009	2006 2010	2007 2011	2008 2012
Product Code	X	x	<u>X</u>	<u>x</u>

Date Code Table

WK01	WK02	WK03	WK04	WK05	WK06	WK07	WK08	WK09	WK10	WK11	WK12	WK13
A	B	C	D	E	F	G	H	I	J	K	L	M
WK14	WK15	WK16	WK17	WK18	WK19	WK20	WK21	WK22	WK23	WK24	WK25	WK26
N	O	P	Q	R	S	T	U	V	W	X	Y	Z
WK27	WK28	WK29	WK30	WK31	WK32	WK33	WK34	WK35	WK36	WK37	WK38	WK39
a	b	c	d	e	f	g	h	i	j	k	l	m
WK40	WK41	WK42	WK43	WK44	WK45	WK46	WK47	WK48	WK49	WK50	WK51	WK52
n	o	p	q	r	s	t	u	v	w	x	y	z

Recommended Circuit

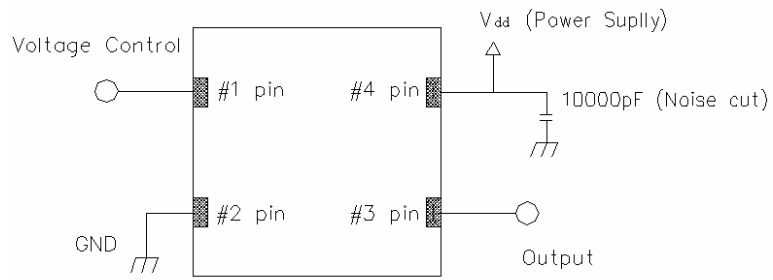

Packing (mm):

1. Reel Dimension

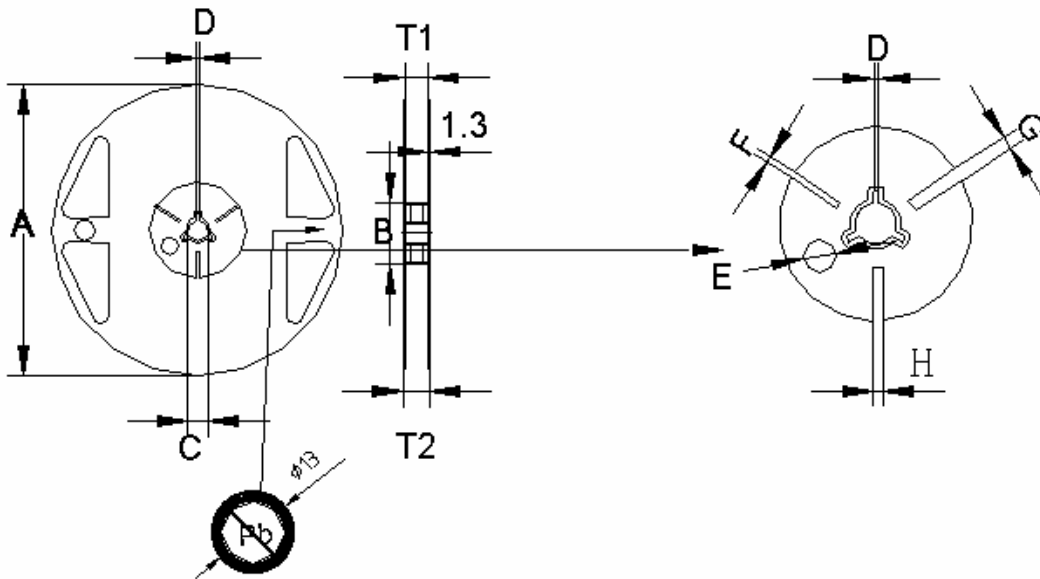

	A	B	C	D	E	F	H	G	T2	T1	T3
Dimensions	180	60	13.0	2.0	9.1	2.9	3.9	4.9	11.4	9.0	1.2
Tolerance	±1.0	+1.0	±0.2	±0.5	±0.5	±0.5	±0.5	±0.5	±1.0	±0.3	±0.1

2. Tape Dimension

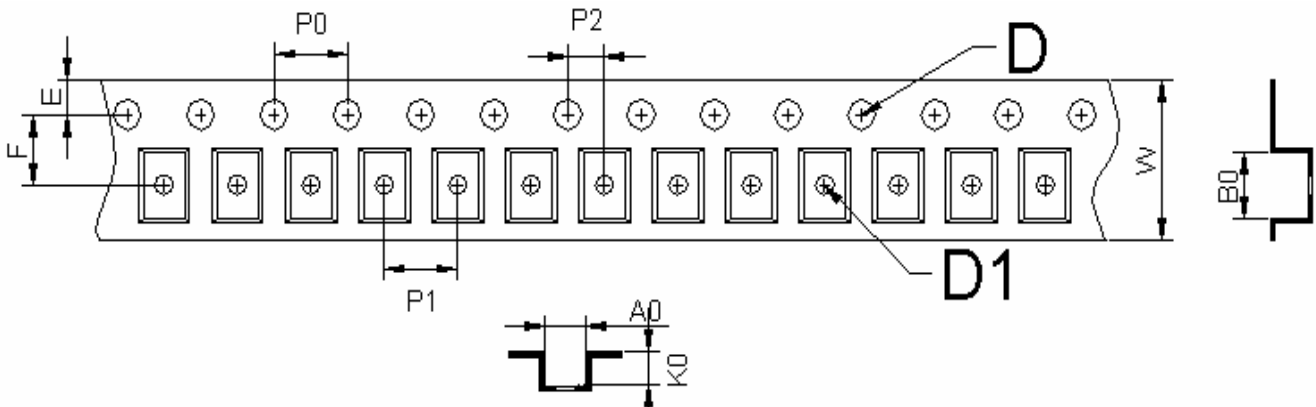

Unit: mm	A0	B0	W	F	E	P0	P1	P2	D1	D	K0	t
Dimension	2.80	3.71	8.00	3.5	1.75	4.00	4.00	2	1.50	1.0	1.75	0.25
Tolerance	±0.1	±0.1	+0.3/-0.1	±0.05	±0.1	±0.1	±0.1	±0.05	+0.1/-0.00	+0.25/-0.00	±0.1	±0.02

Packing Quantity/Packing:

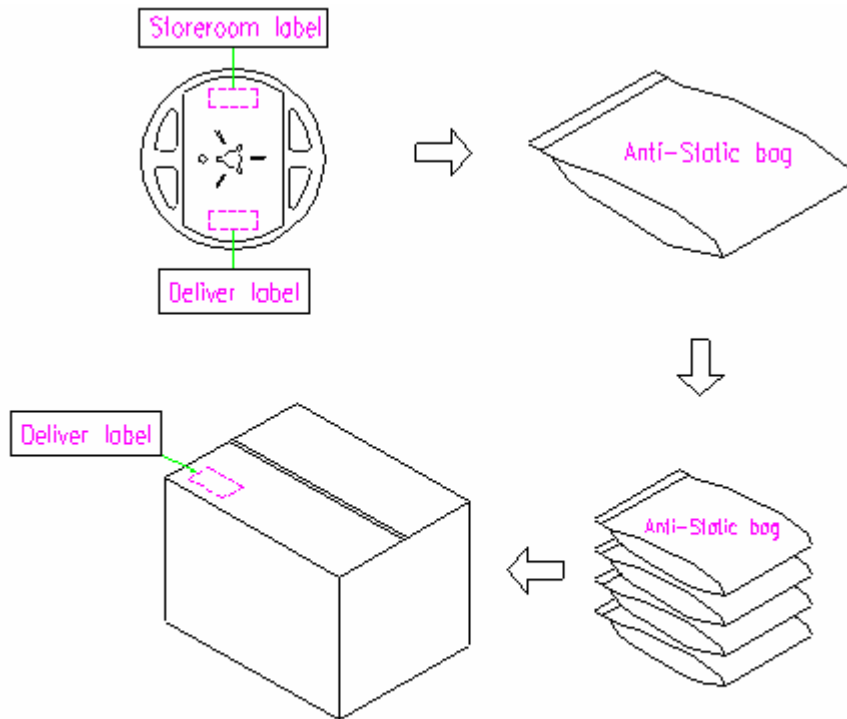

Reflow Profile:

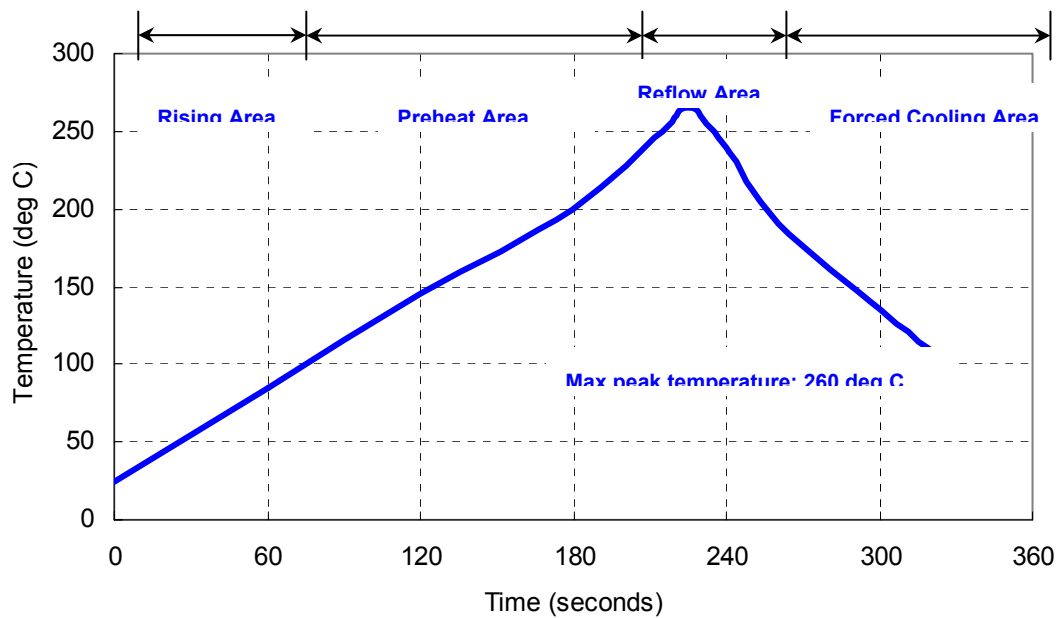

Notes of the Usage:

1. Touch the solder iron at 260 ± 5 deg C onto the leads for 10 ± 2 sec max or touch the solder at 350 ± 5 deg C onto the leads for 3 ± 0.5 sec.
2. In the customer's reflow process, if it will remain some mechanical stress at the soldering terminals, also make some cracks on the soldering termination. Some cracks will cause open or short circuit and cause of thermal increasing or smoking. Don't make any excess mechanical stress to soldering points.
3. In case of giving a heavy shock to the products, it may make an open or short circuit and cause of thermal increasing and smoking. To avoid heavy shock impact applying to products is strictly required.

Notes of the Storage:

1. To keep products under the condition at the room temperature ($-5\sim 35$ deg C) with normal humidity (45~75%). Absorption of moisture and dewdrop may make inferiority of characteristics and a short circuit.
2. Oxidization of terminals shall make the solderability more inferior. Dusts and corrosive gas will make a cause of the open or short circuit. Keep it in the clean place where is not in dusty and no corrosive gas.
3. Use the anti-static material to the storage package.
4. Don't put any excess weight to the TCXO in the storage process.
5. Don't move the product from the cold place to the hot place in the short time, otherwise it may make some dew-drop, then a short circuit may happen in case.
6. Storage periods should be maximum 6 months under condition of above item 1 after delivery from TST factory.
7. Once open the bag, there is possibility of electrical characteristics deterioration due to absorption of moisture. So, please use parts within 7 days after opening the bag.
8. If you have to keep parts without using after opening the bag, please put the drying agent in the bag, fold the bag and keep it in the place where temperature and humidity are controlled (nitrogen atmosphere box etc.)