



# TAI-SAW TECHNOLOGY CO., LTD.

No. 3, Industrial 2nd Rd., Ping-Chen Industrial District,  
Taoyuan, 324, Taiwan, R.O.C.  
TEL: 886-3-4690038 FAX: 886-3-4697532  
E-mail: [tstsales@mail.taisaw.com](mailto:tstsales@mail.taisaw.com) Web: [www.taisaw.com](http://www.taisaw.com)

## Product Specifications Approval Sheet

Product Name: TCXO SMD 3.2x2.5 32.768MHz

TST Part No.: TX0449BA1130

Customer Part No.: \_\_\_\_\_

<p>Company: _____</p> <p>Division: _____</p> <p>Approved by: _____</p> <p>Date: _____</p>
---

Checked by: Glen Peng *Glen*

Approved by: Kelly Huang *Kelly Huang*

Date: 06/16/2023

1. Customer signed back is required before TST can proceed with sample build and receive orders.
2. Orders received without customer signed back will be regarded as agreement on the specifications.
3. Any specifications changes must be approved upon by both parties and a new revision of specifications shall be released to reflect the changes.



**TAI-SAW TECHNOLOGY CO., LTD.**  
**TCXO SMD 3.2x2.5 32.768MHz**

MODEL NO.: TX0449BA1130

REV. NO.: 1

**Revise:**

Rev.	Rev. Page	Rev. Account	Date	Ref. No.	Revised by
1	N/A	Initial release	06/16/23'	N/A	Glen Peng



# TAI-SAW TECHNOLOGY CO., LTD.

No. 3, Industrial 2nd Rd., Ping-Chen Industrial District,  
Taoyuan, 324, Taiwan, R.O.C.

TEL: 886-3-4690038 FAX: 886-3-4697532

E-mail: [tstsales@mail.taisaw.com](mailto:tstsales@mail.taisaw.com) Web: [www.taisaw.com](http://www.taisaw.com)

## TCXO SMD 3.2x2.5 32.768MHz

MODEL NO.: TX0449BA1130

REV. NO.: 1

### Features:

- Ultra Miniature SMD Package
- Good Frequency Stability
- Good Phase Noise Response
- Moisture Sensitivity Level (MSL) : Level-1

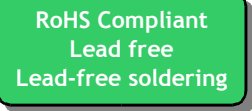

### Description and Applications:

Surface mount 3.2mmx2.5mm TCXO for use in wireless communications devices

### Electrical Specifications:

TX0449BA1130	Specifications
Nominal Frequency, Fo	32.768 MHz
Storage Temperature Range	-40°C to +85°C
Operating Temperature Range	-30°C to +85°C
Power Supply Voltage, Vcc	3.3 V +/- 5%
Output Voltage with Load 10pF//10KΩ, Vout	0.8 Vp-p min
Output Waveform	Clipped Sinewave
Power Supply Current, Icc	2.0 mA max
Frequency Tolerance as received	+/- 1.0 ppm max @ 25°C +/- 3°C
Frequency Tolerance after reflow	+/- 1.0 ppm max @ 25°C +/- 3°C
Frequency Stability a. Vs. Temperature (-30~85°C) b. Vs. Load varied 10pF//10KΩ+/-10% c. Vs. Supply Voltage varied Vcc+/-5%	+/- 1.0 ppm reference to 25°C +/- 0.2 ppm +/- 0.3 ppm
Start Up Time (90% of final RF level in Vp-p)	3.0 msec max.
Aging	+/-1.0 ppm/year @25°C
Harmonics	-5.0 dBc max
SSB Phase Noise (@1KHz Carrier Offset)	-130 dBc/Hz max

Mechanical Dimensions (mm):

Top View

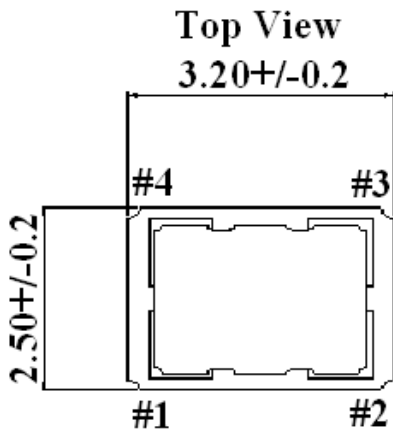

Side View

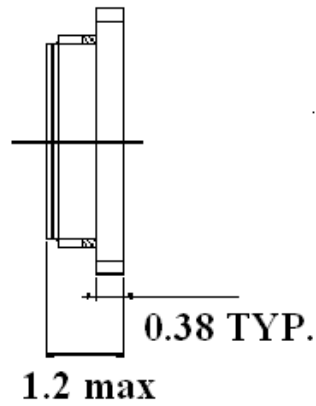

Bottom View

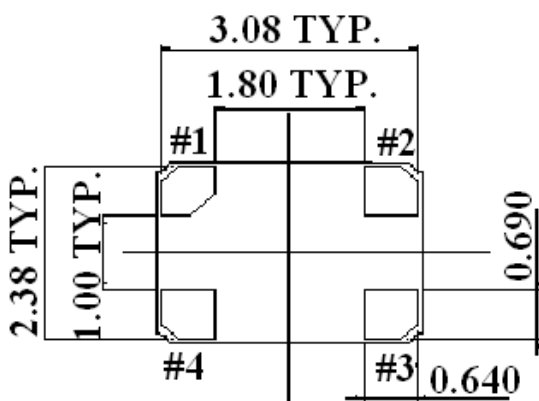

Unit:mm

Pin Out For TCXO	
Pin#	Pin Connection
1	Ground Recommended
2	GND
3	Output
4	Vcc

Recommended Land Pattern: (unit: mm)

Recommend Land Pattern

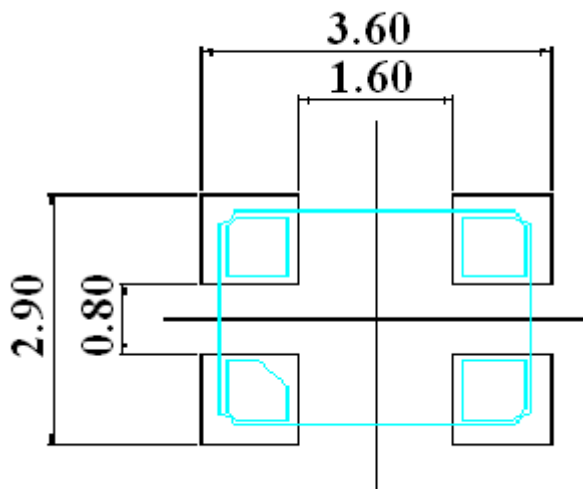

# Marking:

Line 1: Customer Frequency (32.7)

Line 2: TST Logo + Date Code + Product Code (  is TST internal tracking code, could be a~z and A~Z)

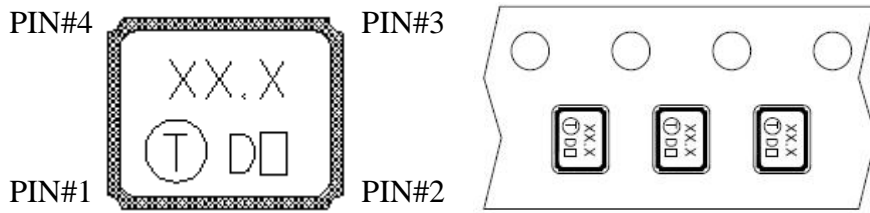

## Date Code Table

WK01	WK02	WK03	WK04	WK05	WK06	WK07	WK08	WK09	WK10	WK11	WK12	WK13
A	B	C	D	E	F	G	H	I	J	K	L	M
WK14	WK15	WK16	WK17	WK18	WK19	WK20	WK21	WK22	WK23	WK24	WK25	WK26
N	O	P	Q	R	S	T	U	V	W	X	Y	Z
WK27	WK28	WK29	WK30	WK31	WK32	WK33	WK34	WK35	WK36	WK37	WK38	WK39
a	b	c	d	e	f	g	h	i	j	k	l	m
WK40	WK41	WK42	WK43	WK44	WK45	WK46	WK47	WK48	WK49	WK50	WK51	WK52
n	o	p	q	r	s	t	u	v	w	x	y	z

## Product Code Table: (Under line With Even Year and Odd Year for Nothing)

Year						Product Code
2023	2025	2027	2029	2031	2033	<input type="checkbox"/>
2024	2026	2028	2030	2032	2034	<input type="checkbox"/>

## Recommended Circuit

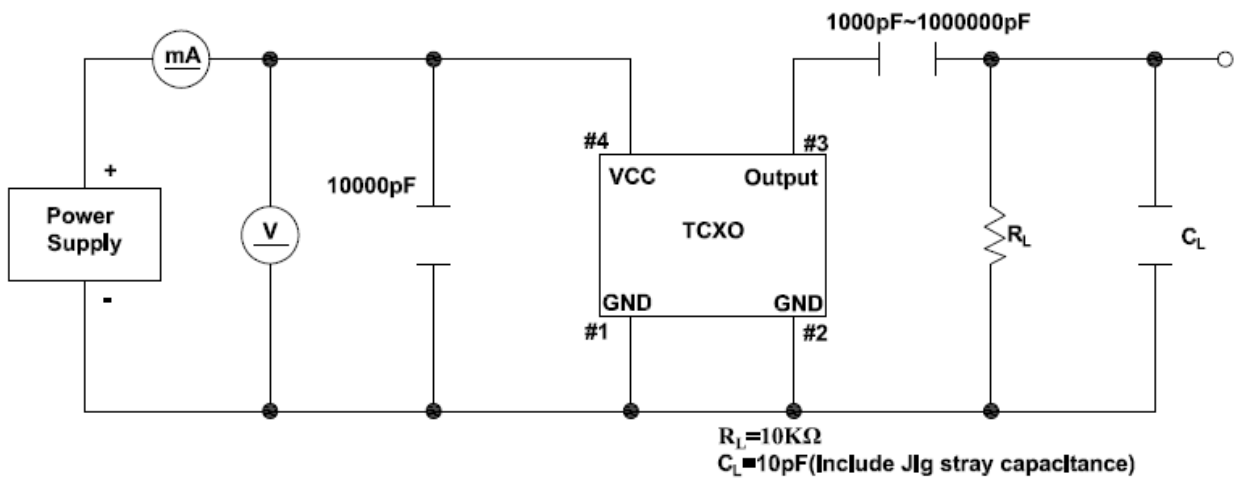

# Packing (mm):

## 1. Reel Dimension

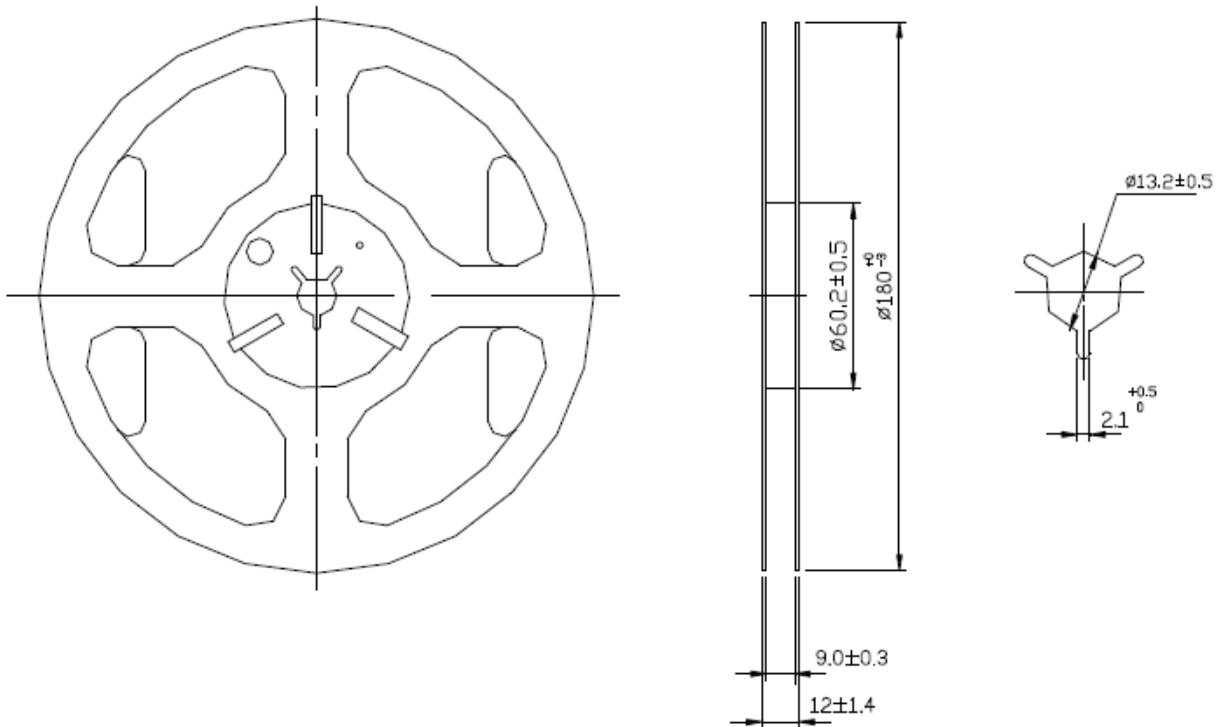

2.

## Tape Dimension

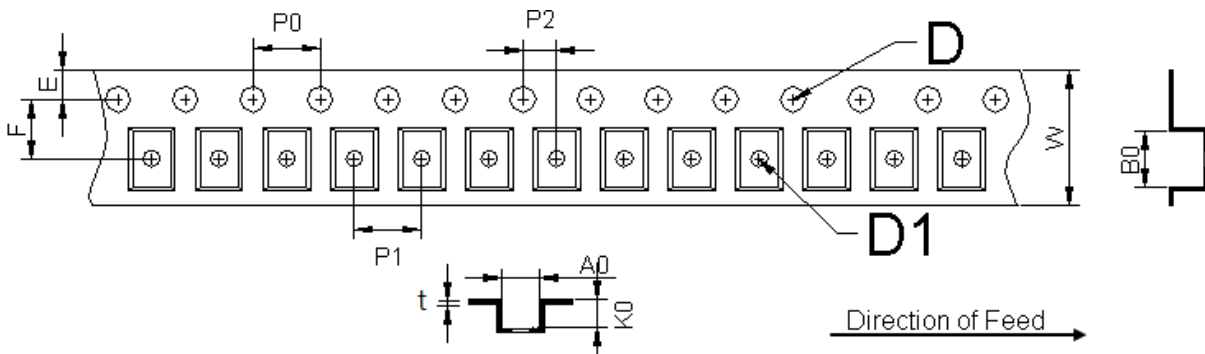

Unit: mm	A0	B0	W	F	E	P0	P1	P2	D1	D	K0	t
Dimension	2.80	3.71	8.00	3.5	1.75	4.00	4.00	2	1.50	1.0	1.75	0.25
Tolerance	$\pm 0.1$	$\pm 0.1$	$+0.3/-0.1$	$\pm 0.05$	$\pm 0.1$	$\pm 0.1$	$\pm 0.1$	$\pm 0.05$	$+0.1/-0.00$	$+0.25/-0.00$	$\pm 0.1$	$\pm 0.02$

## Packing Quantity/Packing:

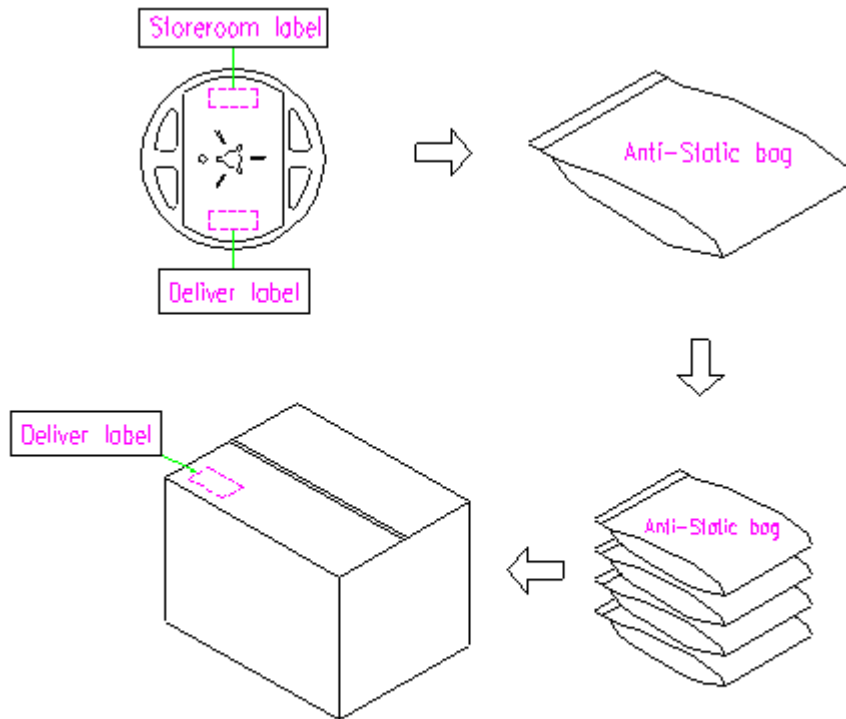

## Reflow Profile:

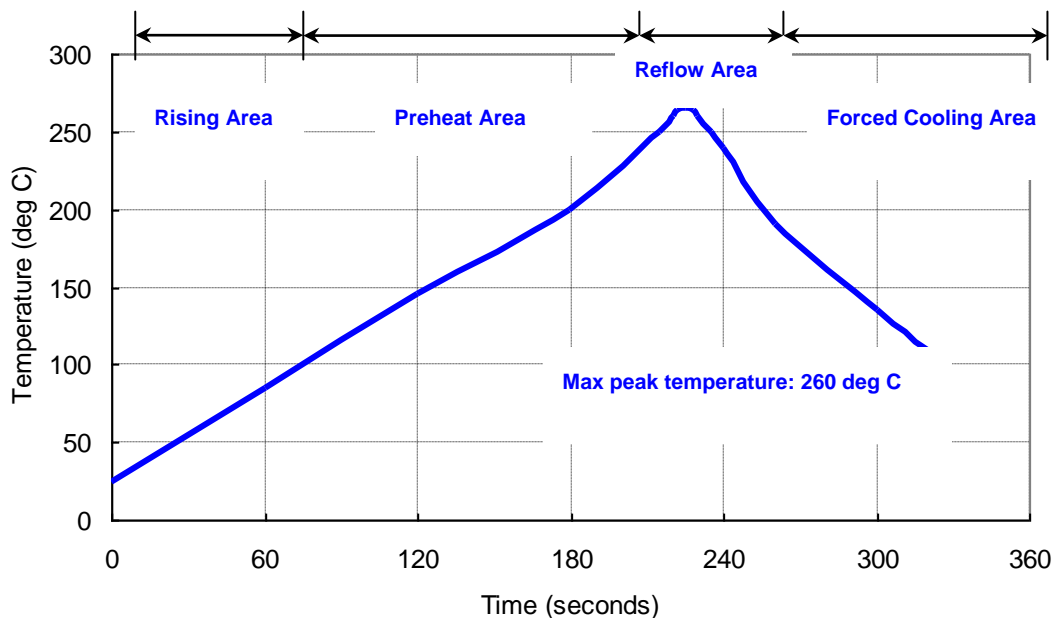

## Notes of the Usage:

1. Touch the solder iron at 260+/-5 deg C onto the leads for 10+/-2 sec max or touch the solder at 350+/-5 deg C onto the leads for 3+/-0.5 sec.
2. In the customer's reflow process, if it will remain some mechanical stress at the soldering terminals, also make some cracks on the soldering termination. Some cracks will cause

open or short circuit and cause of thermal increasing or smoking. Don't make any excess mechanical stress to soldering points.

3. In case of giving a heavy shock to the products, it may make an open or short circuit and cause of thermal increasing and smoking. To avoid heavy shock impact applying to products is strictly required.
4. Ultrasonic cleaning should be avoided to prevent damage to the TCXO.
5. Do Not Use Ultrasonic-Wave Soldering or Wave Solder with Package Immersed in Solder.

## **Notes of the Storage:**

1. To keep products under the condition at the room temperature (-5~35 deg C) with normal humidity (45~75%). Absorption of moisture and dewdrop may make inferiority of characteristics and a short circuit.
2. Oxidization of terminals shall make the solderability more inferior. Dusts and corrosive gas will make a cause of the open or short circuit. Keep it in the clean place where is not in dusty and no corrosive gas.
3. Use the anti-static material to the storage package.
4. Don't put any excess weight to the TCXO in the storage process.
5. Don't move the product from the cold place to the hot place in the short time, otherwise it may make some dew-drop, then a short circuit may happen in case.
6. Storage periods should be maximum 6 months under condition of above item 1 after delivery from TST factory.
7. Once open the bag, there is possibility of electrical characteristics deterioration due to absorption of moisture. So, please use parts within 7 days after opening the bag.
8. If you have to keep parts without using after opening the bag, please put the drying agent in the bag, fold the bag and keep it in the place where temperature and humidity are controlled (nitrogen atmosphere box etc.)



## Reliability Specifications

Test name	Test process / method	Reference standard
<b>Mechanical characteristics</b>		
resistance to Soldering heat (IR reflow)	Temp./ Duration : 265°C /10sec ×2 times Total time : 4min.(IR-reflow)	EIAJED-4701  -300(301)M(II)
Vibration	Total peak amplitude : 1.5mm Vibration frequency : 10 to 2000 Hz Sweep period : 20 minute Vibration directions : 3 mutually perpendicular Duration : 2 hr / direc.	MIL-STD 202G method 204
Mechanical Shock	directions : 3 impacts per axis Acceleration : 3000g's, +20/-0 % Duration : 0.3 ms (total 18 shocks) Waveform : Half-sine	MIL-STD 202G method 213
Solderability	Solder Temperature:265±5°C Duration time: 5±0.5 seconds.	J-STD-002
<b>Environmental characteristics</b>		
Thermal Shock	Heat cycle conditions -40 °C (30min) ↔ 85 °C (30min) * cycle time : 10 times	MIL-STD 883G method 1010.8
Humidity test	Temperature : 85 ± 2 °C Relative humidity : 85% Duration : 96 hours	MIL-STD 202G method 103
Dry heat ( Aging test )	Temperature : 125 ± 2 °C Duration : 168 hours	MIL-STD 202G method 108A
Cold resistance (Low Temp Storage)	Temperature : -40 ± 2 °C Duration : 96 hours	IEC 60068-2-1