



TAI-SAW TECHNOLOGY CO., LTD.

No. 3, Industrial 2nd Rd., Ping-Chen Industrial District,
Taoyuan, 324, Taiwan, R.O.C.
TEL: 886-3-4690038 FAX: 886-3-4697532
E-mail: tstsales@mail.taisaw.com Web: www.taisaw.com

Product Specifications Approval Sheet

Product Description: Crystal Filter SMD 5x7 30.72MHz

TST Part No.: TY0153A

Customer Part No. : _____

Customer signature required
Company: _____
Division: _____
Approved by : _____
Date: _____

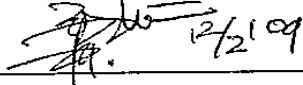
Checked by: Eddie Huang  12/21/09

Approved by: Robert Chang 

Date: 12/02/2009

1. Customer signed back is required before TST can proceed with sample build and receive orders.
2. Orders received without customer signed back will be regarded as agreement on the specifications.
3. Any specifications changes must be approved upon by both parties and a new revision of specifications shall be released to reflect the changes.



TAI-SAW TECHNOLOGY CO., LTD.

Crystal Filter SMD 5x7 30.72MHz

MODEL NO.: TY0153A

REV. NO.: 1

Revise:

Rev.	Rev. Page	Rev. Account	Date	Ref. No.	Revised by
1	N/A	Initial release	12/02/09	N/A	Eddie Huang



TAI-SAW TECHNOLOGY CO., LTD.

No. 3, Industrial 2nd Rd., Ping-Chen Industrial District,
Taoyuan, 324, Taiwan, R.O.C.

TEL: 886-3-4690038 FAX: 886-3-4697532

E-mail: tstsales@mail.taisaw.com Web: www.taisaw.com

Crystal Filter SMD 5x7 30.72MHz

MODEL NO.: TY0153A

REV. NO.: 1

Features:

- Surface Mount Seam Weld Package
- 2-pole IF Filter
- High Reliability

RoHS Compliant
Lead free
Lead-free soldering

Description and Applications:

Surface mount 5.0mmx7.0mm crystal filter for use in wireless telecommunication devices.

Electrical Specifications:

TY0153A	Specification
Center Frequency Fo	30.72 MHz, Fundamental
Insertion Loss	2.0 dB max.
Ripple	1.0 dB max.
3 dB Passband	+/- 4KHz
Stopband (@ +/- 60 KHz)	40 dB min
Ultimate Attenuation @ Fo-910 KHz	60 dB min
Spurious	20 dB min
Terminating Impedance	650Ω// 4.5pF
Operating Temperature	-20°C ~ +70°C
Marking	Laser marking

Mechanical Dimensions (mm):

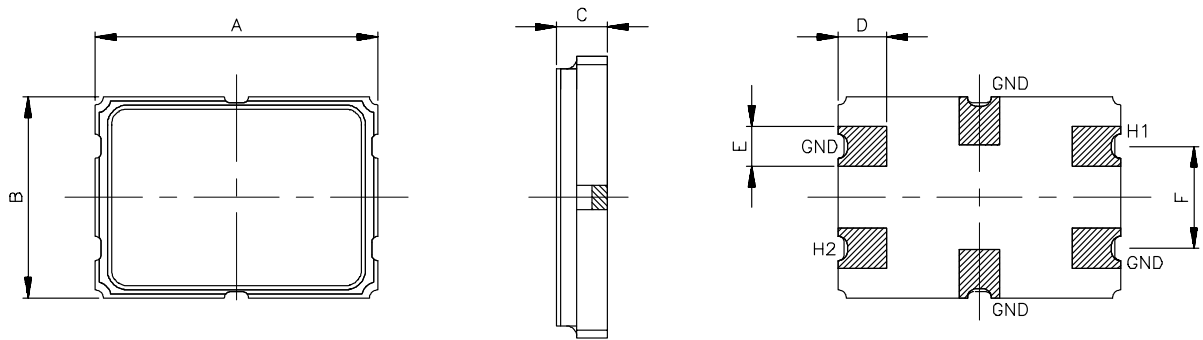

A	B	C	D	E	F
7.00	5.00	1.27	1.21	0.99	2.54
±0.18	±0.18	±0.20	±0.13	±0.13	±0.13

Marking:

Line 1: 30.720 (Customer Frequency)

Line 2: TST Logo + Crystal Filter Product Code + Date Code

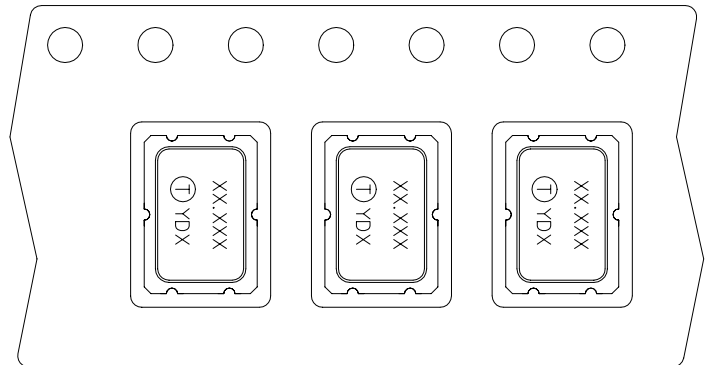
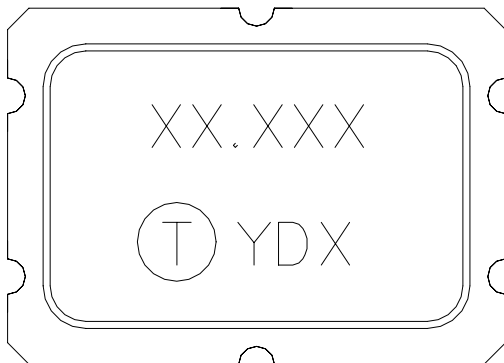

Product Code Table

Year	2009	2010	2011	2012
	2013	2014	2015	2016
	2017	2018	2019	2020
product code	Y	y	Y	y

Date Code Table

WK01	WK02	WK03	WK04	WK05	WK06	WK07	WK08	WK09	WK10	WK11	WK12	WK13
A	B	C	D	E	F	G	H	I	J	K	L	M
WK14	WK15	WK16	WK17	WK18	WK19	WK20	WK21	WK22	WK23	WK24	WK25	WK26
N	O	P	Q	R	S	T	U	V	W	X	Y	Z
WK27	WK28	WK29	WK30	WK31	WK32	WK33	WK34	WK35	WK36	WK37	WK38	WK39
a	b	c	d	e	f	g	h	i	j	k	l	m
WK40	WK41	WK42	WK43	WK44	WK45	WK46	WK47	WK48	WK49	WK50	WK51	WK52
n	o	p	q	r	s	t	u	v	w	x	y	z

Packing Quantity/Packing:

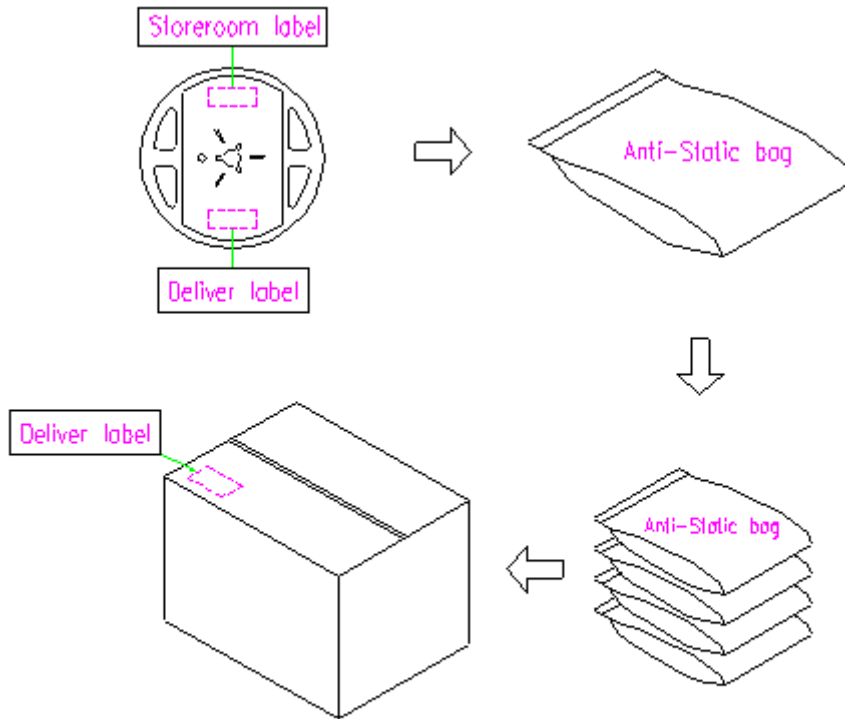

Reflow Profile:

